



MINICON 15

Program book

СТРАЖИТНОГ ЗО АЛЖБАТ

Stuff.....2 - 39

Artwork:

Covers and p. 8 by Jim Odbert
pp. 11, 33 by Kathy Marschall
p. 18 by Alexis Gilliland
pp. 27, 30 Teddy Harvia
Map, p. 22 by Linda Lounsbury

Illustrations on pages 2 and 6 of Progress
Report 5 by Alexis Gilliland.

Hotel checkout time is normally 1:00 pm. It
has been extended until 5:00 pm on Sunday,
April 15, for convention members.

As of press time, certain details had not yet
been worked out. There will probably be a
computer room. There may be a room designated
for playing war and other games. And some
sort of baby-sitting cooperative may be
arranged. Look for signs, or ask at regis-
tration.

All material herein is copyright © 1979 by the
Minnesota Science Fiction Society, Inc. Upon
publication all rights revert to the author or
artist. All uncredited material is the re-
sponsibility of the Publications Staff.

IMPORTANT STUFF

NAME BADGES AND TAGS: Because of the size of
the con, it is absolutely essential that you
wear your official name badge or tag. Without
it, you will not be admitted into any function
(including the party suite). There will be
blue meanies to enforce this; try not to run
afoul of them. We appreciate your cooperation.

REGISTRATION and INFORMATION: Registration
will be open in the Star of the North Hall
Section 3, from 11:00 am until 6:00 pm Friday,
from 10:00 am until 6:00 pm Saturday, and from
10:00 am until whenever, Sunday. In the same
room, Minicon T-shirts, books, and Frisbees
will be for sale. At other times it will be
possible to register at the Bridge, on the
twelfth floor across from the con suite. The
Bridge will always be staffed by a committee
member. Which brings us to --

THE CON SUITE and THE BRIDGE are located on
the twelfth floor. The easiest way to get
there is to take one of the main elevators to
the eleventh floor, go through the wooden
gates up a flight of stairs. Other arrange-
ments are available for the mobility-
impaired -- ask a committee member.

BANQUET: A limited number of banquet tickets
are still available. Purchase them at regis-
tration. For \$11.00 you have your choice of
(1) Turkey Canoe; Turkey with cheese, bacon
and supreme sauce; Minnesota wild rice soup;
peas and mushrooms; salad; cornbread; sun-
flower seed ice cream; or
(2) Tyler Too; Roast top sirloin of beef in
champignon sauce; Parisienne potatoes; peas
and mushrooms; Bavarian cream cake.

COMMITTEE MEMBERS: can be identified by blue name badges/buttons unless trying to hide in the crowd. They're willing to try to help you with any problems or requests; please remember that they have been, and still are, very busy with this con -- be patient.

GOFERS: also known as the Minnesota Gofers, these are the people who help carry out the innumerable little tasks that pop up during a con to harass the rest of the con Committee. Their contributions, generally little-noticed, are nonetheless essential, and are greatly appreciated by all of us. If you'd like to be one of this stalwart little band, trot over to the Registration Room and look for Don Bailey, top-banana of the bunch. Don't slip.

RUNE: The club fanzine of the Minnesota Science Fiction Society, Inc. (Minn-stf) is available to convention members for \$2.00 for a year's subscription (4 issues, most likely). Rune is edited by Lee Pelton and Carol Kennedy.

LIQUOR STORES

Since Minnesota is a rather backward state regarding liquor laws, should you find yourself running dangerously low on alcohol and it's after 8 pm you are out of luck. You have been warned.

I can't understand the reasoning behind this early closing time, since most serious drinkers don't get up much before 7. There is no use crying over spilt milk or closed stores. The nearest liquor store is in the Hotel on the ground floor. It is reasonably priced.

PLEASE: NO FRISBEEING IN THE CON SUITE!!!!

A RESTAURANT GUIDE offering suggestions for local dining is available; pick one up.



**Captivating
-from opening
tragedy
to concluding
triumph...**

"When originally published as a novella, the first part of this novel won both the Nebula and Hugo; the complete novel may just repeat that sweep. Shara Drummond invents zero-g dance, uses it to talk to some very strange aliens... By the end, Shara's sister and the man who loves them both come to know these same aliens and with their help lead humanity from its planetary womb to the next evolutionary stage... Authenticity provided by a co-author who is a professional dancer... Sheer good storytelling." —*Publishers Weekly*
A Selection of The Science Fiction Book Club. \$8.95

SPIDER AND JEANNE ROBINSON Stardance

QUANTUM SCIENCE FICTION

The Dial Press/James Wade

THE DIAL PRESS DELL PUBLISHING CO., INC.

Gordon R. Dickson

autographing

Gordon R. Dickson will autograph his books at Minicon, 4:00 p.m. Saturday, April 14th, 1979 in suite 872-874 of the Radisson Hotel. Books will be available or bring your own. Autographs provided.

speaking

Gordy will be speaking at the University of Minnesota, noon Tuesday, April 24th in Coffman Memorial Student Union. Have some sf for lunch!

Otterburn Associates

Autographed editions of Mr. Dickson's books are available from Otterburn Associates by mail. Write for a book listing or check the 'freebee' table at the Minicon registration area for our flyer.



OTTERBURN ASSOCIATES Dept. E
P.O. BOX 1896 • ST. PAUL, MINNESOTA 55111



"TO READ SCIENCE FICTION IS TO READ SIMAK"

Robert A. Heinlein

Two riveting tales of alien invasion by the winner of the Hugo and International Fantasy Awards and the Grand Master Nebula!

"One of the handful of really competent writers of science fiction."

Gordon R. Dickson, *Minneapolis Tribune*

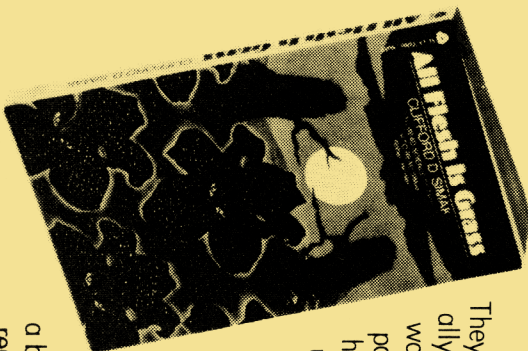

They appear to be simple purple flowers but are actually a complex data system that sweeps from world to world, dimension to dimension. They offer man partnership and "salvation"—but Brad Carter wonders how many other earths lie swept clean by this unstoppable profusion of sentient flowers... \$1.75

A small midwestern town is hit by a series of strange events—and some—one is gobbling up all the real estate in a big way. When science reporter Parker Groves' own lease is suddenly terminated, he decides to dig for the truth. The bizarre trail leads to outer space—and a "reditor" who buys not just cities, but solar systems... \$1.95

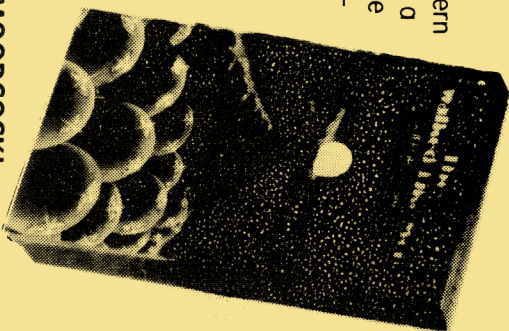

NEW FROM MICHAEL MOORCOCK!

A sublimely erotic excursion through medieval realms of fantastical beauty—and an elaborate plot to gain control of the world's most glorious empire!
"Outstandingly written... a remarkable book, teeming with extraordinary life and complexity."—*London Spectator* "Spellbinding"—*London Times* Six full-page illustrations... AVON Trade Paperback... \$4.95
(Also by Michael Moorcock, available from AVON: THE CORNELIUS CHRONICLES trilogy, DANCERS AT THE END OF TIME trilogy, BEHOLD THE MAN!)



MAN'S GREATEST INTERSTELLAR QUEST...

GALACTIC EMPIRES Volumes I and II Edited by Brian Aldiss

26 stories by the masters of science fiction—Clarke, Asimov, Anderson, Simak, Harrison, van Vogt and more—collected into an extraordinary anthology that chronicles the rise and fall of vast interstellar civilizations! \$2.25 each volume

AVON PAPERBACKS

GUEST OF HONOR: THEODORE STURGEON



LOVE STORY
or
One man's opinion of the writings of
Theodore Sturgeon

I have never met Theodore Sturgeon, except between the covers of a paperback book or some dusty, neglected, precious pulp magazine. So I am surprised to find that I also feel that I know Ted Sturgeon, human being, as well as Theodore Sturgeon, author. Sturgeon talks to me as no other writer ever has.

One thing shows up again and again in his writings: he has an overwhelming love for the human race. And he understands, in depth, all the weaknesses we are so prone to. He speaks to those who care about people while knowing that a human's good and evil sides are inextricably woven and often interchange subtly. Recognizing this without condemning people for it makes Sturgeon a writer unlike any other I have discovered.

My own personal judgement of whether a story is good depends on the degree to which the author can get me to care about what is going on. Better yet is the story that makes me care about the characters I'm following through the maze of plot. The best ones are those that tell me, in language I can understand, how something that is happening to the character is related to something that has happened to me. The list of stories in that category is very short; a disproportionate number of them are by Theodore Sturgeon.

He can give us horror, in stories like "Killdozer", "It", and "Memorial". But he can tell poignant love stories, as shown in "Case and the Dreamer", "Bright Segment", and the once-daring novel Venus Plus X. Two of the funniest short stories I have ever read are his "Ether Breather" and its sequel "Butyl and the Ether Breather". "The Pod in the

Barrier" helped me shape an opinion that I hold to this day, that EVERYBODY has some value, in their own way, if you look hard enough at the right time. "Maturity" is a story that means much to me because Robin English, in attaining his goal, reminds me that too much of anything, no matter how good, can be deadly. (You can buy the special edition of this story, published for MINICON, and discover what it means to you.)

Sturgeon is a man who can weave words, involve your emotions, make you think, make you feel glad to be alive. His gift is in knowing people and being able to put that knowledge on paper for us to share. Truly, All his stories are love stories.

I guess that what I feel about Ted Sturgeon is really pretty simple: I love the man, I love his writing. And when I finally get to meet him, I think I will be meeting an old and dear friend -- for the first time.

Lee Pelton

Theodore Sturgeon was born on February 26th 1918, in New York City. And though he, at various times and places, served in the Merchant Marine, managed a hotel, and operated a bulldozer, he never fulfilled his early ambition to be a circus aerialist.

His first published science fiction story was "Ether Breather". in the September, 1939. Astounding. Since then he has won the British Argosy Short Story Contest with "Bianca's Hands" (1947), won the International Fantasy Award for More Than Human (1959), and both the Hugo and the Nebula awards for "Slow Sculpture" (1971). He has been a book reviewer for Venture and Galaxy, was a columnist for If, and written all manner of fiction. Another collection of his short stories will be published soon, entitled The Stars Are the Styx.

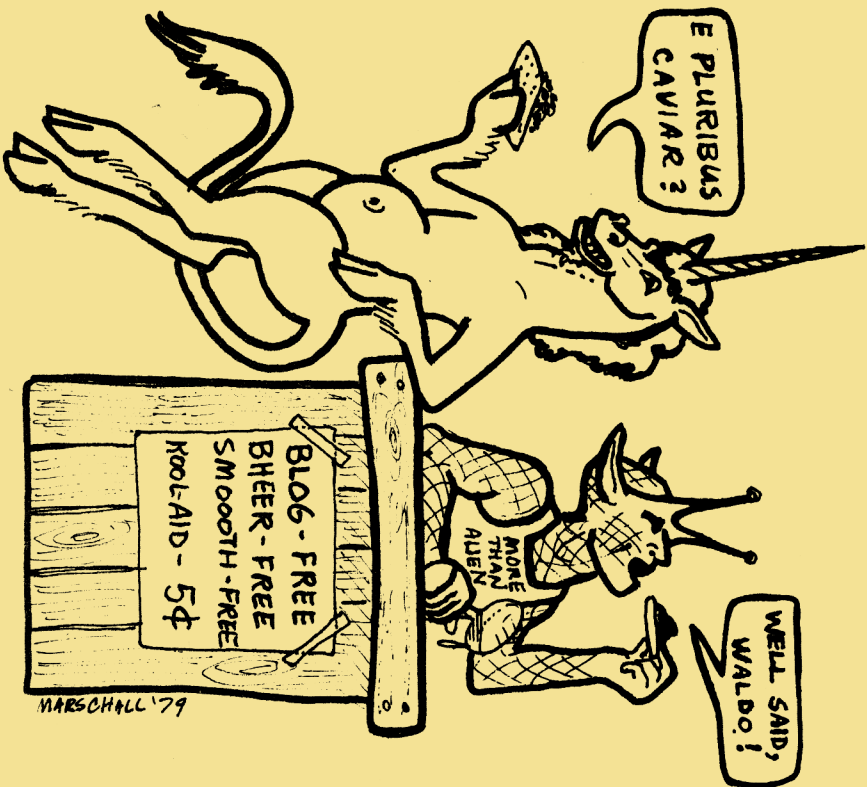

Be Of Stout Heart

IT'S ON ITS
WAY.....

OKon '79

Science Fiction
Convention
July 21-22
Tulsa, Okla.

Okon - Starbase Tulsa
P. O. Box 4229
Tulsa, OK 74104



GoH: Jack Williamson
FGoH: Margaret Middleton
Toastmaster: Bob Asprin
Attending: "Bob" Tucker, James Gunn,
C.J. Cherryh, Lee Killough, and
possibly Frederik Pohl
Two Film Rooms, 65 Table Dealer's Room
The Arthritis Foundation is our charity

12

TOM DIGBY by Nate Bucklin

Chocolate-covered manhole covers. Vacuum Cleaners that vacuum themselves up. Mama and Papa Werewolf arguing over whose turn it is to "change" the baby. Waiting by a sign marked "Not a Bus Stop" until the vehicle marked "Not a Bus" arrives.

All these ideas, and many more, are products of the fertile mind of Thomas Graham Digby, a fan who has dreamed up more scienti-fantastical ideas in fourteen years as an active science fiction fan than many of us have in our libraries. Tom (or Thom, or simply "Digby") has written short stories ("The World of Not-A") free verse ("I sent you a message in a cloud of tachyons..."), songs ("Have you ever been to a part of the world/where people don't believe in the moon?"), cartoons ("No parking. Violaters will be stomped on...") with its accompanying illustration), limericks ("Two Siamese twins from Bombay..."), and countless idea trips like those above. He has also managed to appear as a character in a story by Larry Niven, "What Can You Say About Chocolate Covered Manhole Covers?". Although his writings have generally appeared only in *Apa L* and *Minneapa*, Los Angeles- and Twin Cities-based amateur press associations, to which he contributes regularly, he was nominated for the Hugo award for Best Fan Writer in 1971 and 1972.

In person, Tom is tall, affable, red-haired, and too lively to be 39, with the fastest walking stride I have ever encountered. He also has a distinct southern accent which 15 years of living in the Los Angeles area have done little to eradicate, and possesses the rare ability to liven up a party without having to out-talk, out-drink, or out-sing anybody to do it. Fellow sapient beings, fandom has only one Tom Digby--walk up to him and say "Hi."

13

T ESSERACT I

SCIENCE
FICTION



At last, a magazine dedicated to treating science fiction as a genuine art form. Tesseract, Inc., a not for profit, literary organization introduces Tesseract Science Fiction, Vol. II, No. 1, including art by Phil Foglio and stories by Kevin O'Donnell, Jr. and Lin & D. C. Poyer. Mail order: \$1.00 plus 35¢ postage and handling. Order from: Tesseract Science Fiction, 134 Windward Drive, Schaumburg, IL 60194

TESSERACT SCIENCE FICTION

Available this convention from Imagination Unlimited

Macabre House

P R E S E N T S



webs of

time

by

JOSEPH PAYNE
BRENNAN

with

introduction

by

Frederick S. Meyer

PROGRAMMING

Note: SotN means Star of the North Hall

Friday, April 13

- 11:00 am Sitting in Chairs Contest
-5:00 pm Lobby and Mezzanine
- 11:00 am Registration open
-6:00 pm
- 12 Noon Huckster Room open
-8:00 pm
- 1:00 pm Panel: "Don't Dream It, Be It"
SotN, Sec. 2
- 2:00 pm Art Show open
-8:00 pm
- time to Panel: The Illuminati
be an- Place to be announced
nounced Panelists not to be announced
- 6:00 pm Registration moves to the Bridge
- 6:30 pm OPENING CEREMONIES
SotN, Sec. 2
- 7:00 pm Panel: "How I Got Into Prodom"
with Eleanor Arnason, Phyllis
Eisenstein, Jim Young, others
SotN, Sec. 2
- 8:00 pm Huckster Room and Art Show Close
- 8:00 pm Theodore Sturgeon Reads (out loud)
SotN, Sec. 2
- 9:00 pm Meet-the-Pros Party
Con Suite
- 9:00 pm Films start

Saturday, April 14

- 10:00 am Registration, Huckster Room, Art-
show open
- 12 Noon Panel: "Alternate Energy Sources in
the Future" with Joe Haldeman,
Gary Hudson (Foundation Instit-
ute), Joan Vinge, Mike Kasmarik
a representative from the Nor-
thern States Power Co.; moder-
ator: Neil Rest
SotN, Sec. 2
- 1:00 pm Panel: "High Technology & SF Fan-
dom" with Tullio Proni and
others; moderator: Jon Singer
SotN, Sec. 2
- 2:00 pm Panel: "The History of the Future
(As It Didn't Happen)" with
Gordon R. Dickson, Clifford
Simak, others
SotN, Sec. 2
- 2:00 pm Slide Show: "The Madison Parade of
Cats" with Diane Martin
Gold Room
- 2:30 pm Equal Time For Anti-Cat Fans
with Jeanne Gomoll
Gold Room
- 3:00 pm Panel: "Science Fiction in the
Public Eye" with Jim Frenkel,
(Dell), Joe Haldeman, others
SotN, Sec. 2
- 4:00 pm Art Program --SotN, Sec. 2
-6:00 pm
(a) Rick Sternbach slide show
(b) Panel: "SF Art as Big Bus-
iness" with Joan Harke Woods,
David Egge, David G. Hartwell,
Jim Odbert, Rick Sternbach
(c) David Egge slide show

4:00 pm Discussions: "Why Write Science Fiction?" with Eleanor Arnason -- Con Suite

6:00 pm Huckster Room, Art Show close, Registration moves to the Bridge

6:00 pm BANQUET -- SotN, Sec. 1

7:15 pm After-Dinner Speechifying and Silliness -- SotN, Sec. 1

8:30 pm TAFP/DUFF Auction and first Art Auction -- Mart 3rd Floor

9:30 pm MASQUERADE BALL -- SotN, Sec. 1

10:00 pm Films start, Party Suite opens

12 Midnight
Second Art Auction -- Mart 3rd Floor

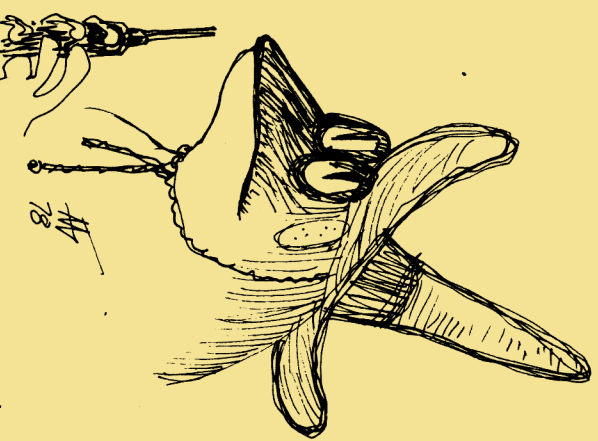

Minicon 15

18

Note: SotN means Star of the North Hall

Sunday, April 15

10:00 pm Registration, Huckster Room, Art-show open

12 Noon Films start

12 Noon Sandra Miesel slide show, "Digging Up the Roots of Fantasy Art" SotN, Sec. 2

12:30 pm Third Art Auction -- Mart 3rd Floor

1:00 pm Panel: "The Changing Nature of Fandom" with Mike Glicksohn and others; moderator: Jerry Kaufman SotN, Sec. 2

1:00 pm Workshop: "Creating Aliens & Worlds" with Gordon R. Dickson, Joan Vinge, others -- Con Suite

2:00 pm Theodore Sturgeon Interviewed (out loud). Interviewers: Denny Lien, Nate Bucklin, Lee Pelton, and Dave Romm -- SotN, Sec. 2

3:00 pm CLOSING CEREMONIES -- SotN, Sec. 2

3:30 pm Open Meeting: Minicon 16 Committee -grumble & gripe- SotN, Sec. 2

5:00 pm Huckster Room, Art Show close

6:00 pm Party Suite opens for Dead Dog Party

19

**PROGRAMMING
MAP**
(subject to changes)

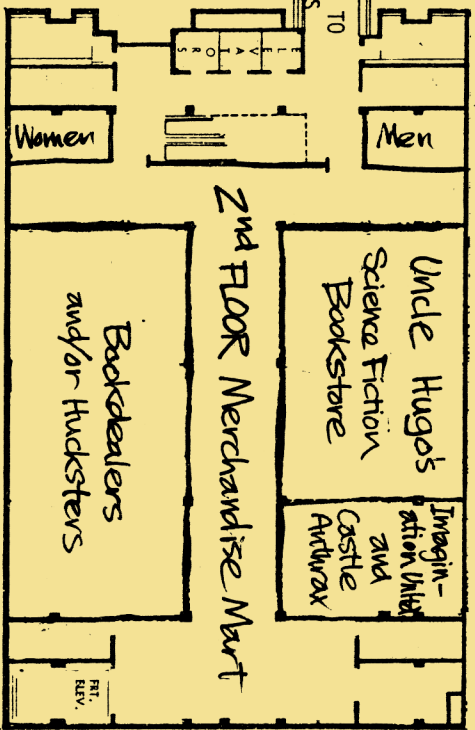
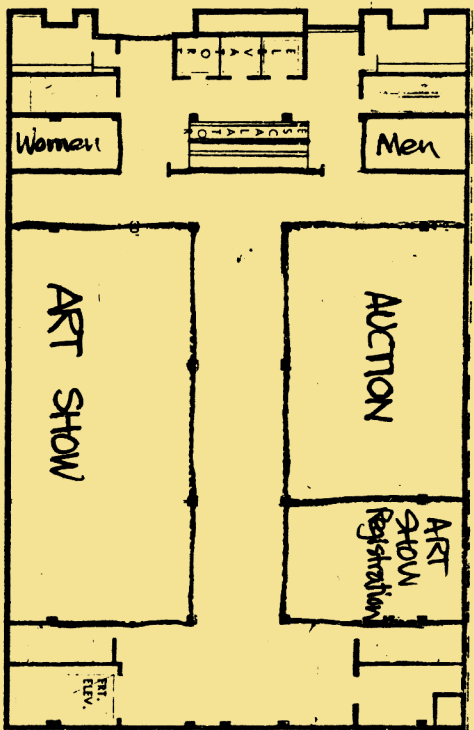
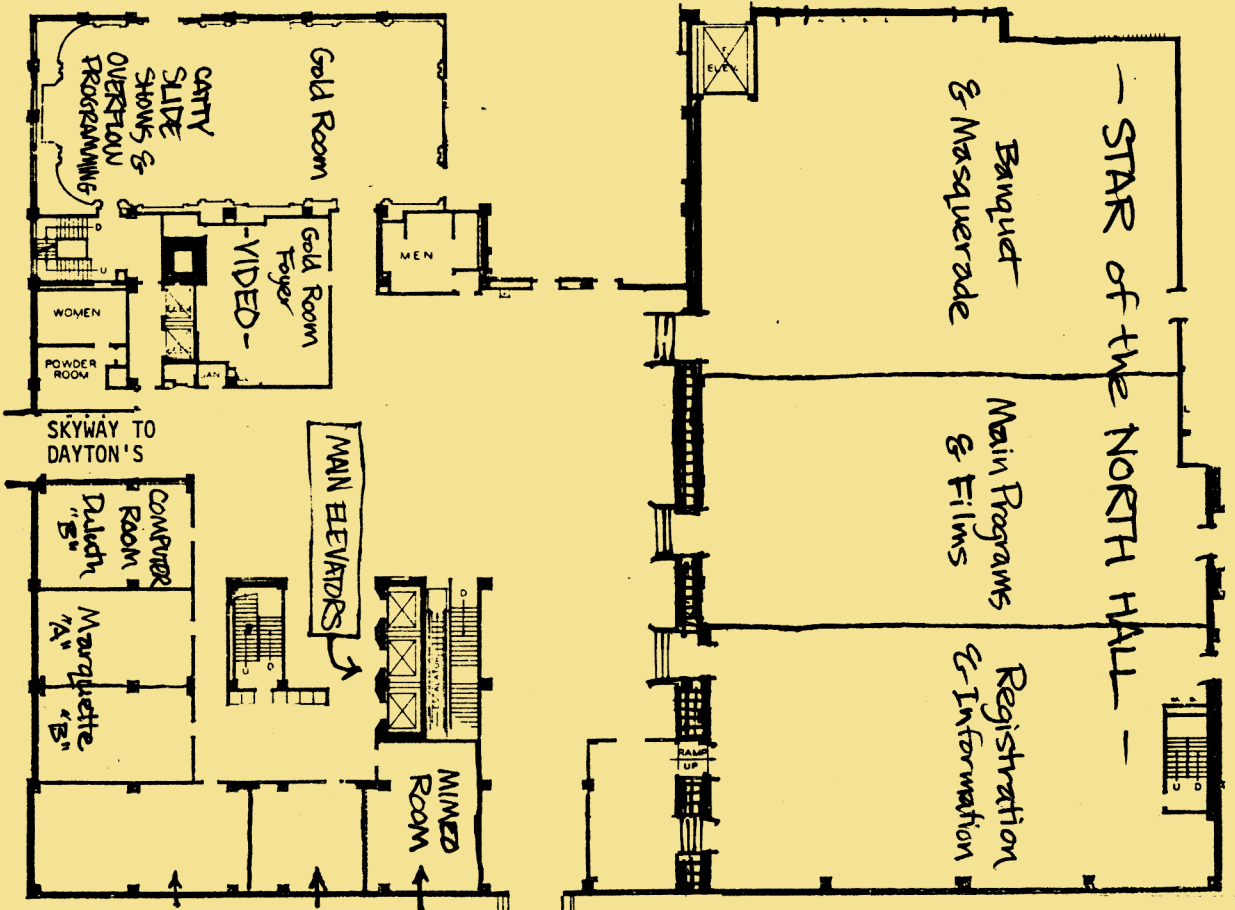

Minicon 15 ~ 1979
 RADISSON HOTEL AND RADISSON MERCHANDISE MART
 MINNEAPOLIS, MINNESOTA 55402

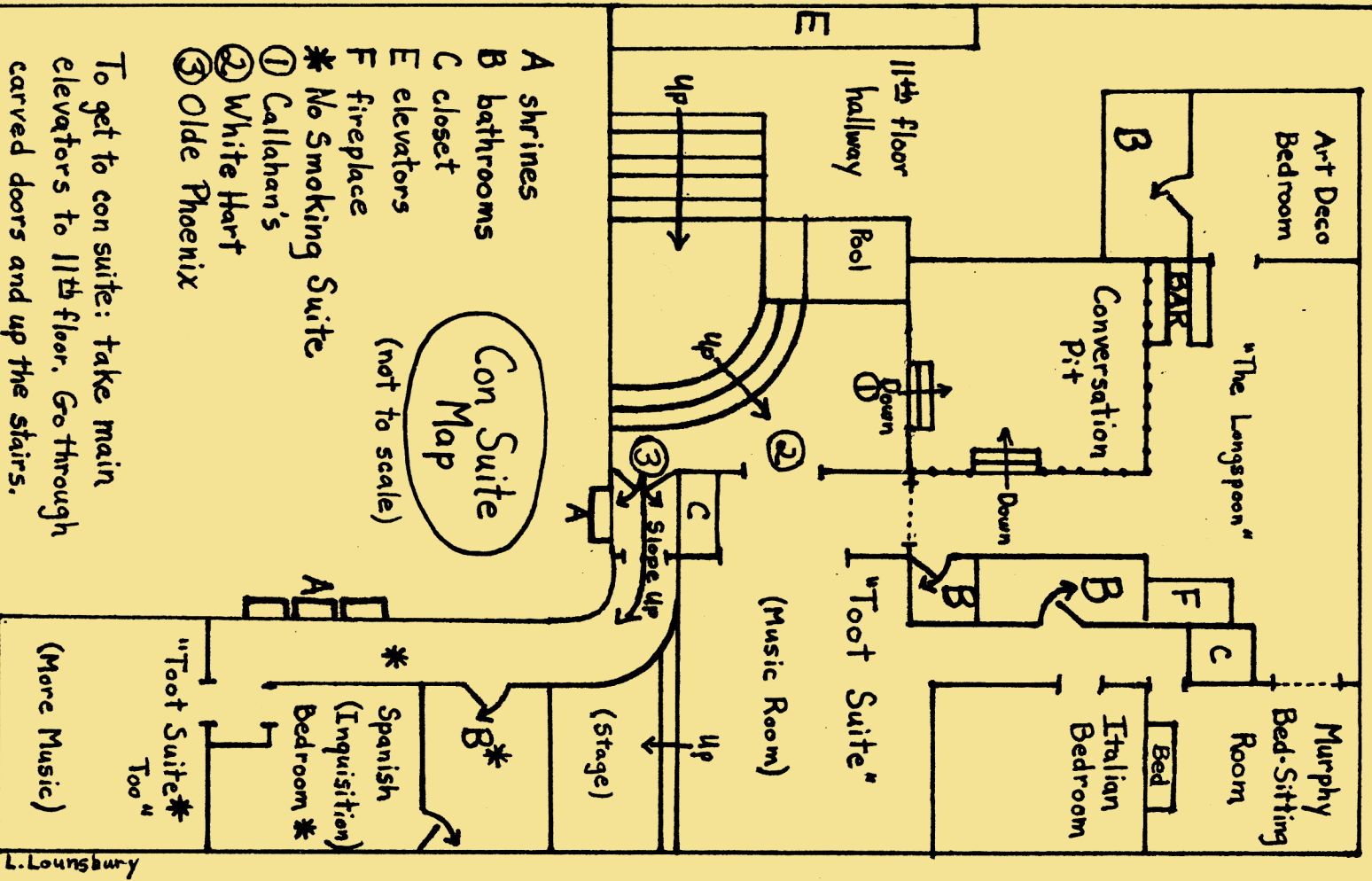

The committee would like to thank Eric von Flamin for the use of his mural in the Star of the North Hall.

Microprogramming Notice

There will be weird (and wonderfully woozy) bits of silliness before all programming items, during the auction, on the elevator and anytime we feel sufficiently strangled by seriousness. There will be no advance warning, though we have harnessed a (widget) and two boffs as bozoid indicators, so keep your eyes open. If you find yourself in the middle of a microprogramming item, don't dream it, be it.

4-SALE

MINICON T-SHIRTS: With designs by Kathy Marschall and Ray Allard. Available in a variety of sizes and colors, but quantities are limited. A steal at \$6.

BOOKS -- MATURITY by THEODORE STURGEON, plus two of his short stories. Also one of the most complete Sturgeon bibliographies ever compiled. And only \$10.

MINN-STF FRISBEES: Special 10 inch (25 centimeter) Frisbees, impaired with the Minn-Stf logo. \$2 -- A bargain at twice the price.

All these items are available in the registration room (Star of the North Hall, Section 3) during regular business hours.

Note of Warning: Since the hotel has never dealt with fans before, please refrain from lighting their employees on fire.

WINNERWINNERWINNERWINNERWINNERWINNERWINNERWINNERWINNERWINNERWINNERWINNERWIN

Erik Biever of St. Paul, Mn. (a local) won the contest for best registration letter (including 2 boxtops) and gets a free Minicon registration for his efforts.

ARTIST GUEST OF HONOR? RICK STERNBACH

I've known Rick (as he's known to his friends) since, oh, I'd say 1974 or so. He came to the Hub back in those days for some unremembered reason -- he said that he was skin diving off the North Shore, but I have my doubts. Those were the Nixon years, you know, and a lot of mighty strange things happened in those days. Things that unless you were a California Republican, you never found out about.

Richard M. (aMadens) Sternbach had just sold his first cover to Ali Ben Bova (these were also the days of the first gasoline shortage, when America found out that Arabs were into more than just coffee beans and horses), and he had heard about the fan group up in Boston, and he paid us a visit or three. By '75 it got to the point where people up there just saved their dirty dishes for ol' Rick to do up on his weekend trips. Yessir, Rick, he surely loved to wash dishes; that and do pizza box cover artwork. Spike MacPhee, one of the people living at Terminus (the center of a lot of his activity, and Rick's hang-out, when he was in town), thought a lot of Rick's work (Spike is not a California Republican, so it must have been Rick's artwork), and he thought that it was his duty to save all those pizza-box covers, and styrofoam cups with "ACE" Farko cartoons, and pictures of Kentucky Fried Denkiri on them.

Asenath Hammond was visiting us a bit, too, and seeing how Rick lived in Connecticut, and she lived in New Orc City, why it was only natural that if'n they were going to be visiting the goodfen of Boston at the same time, that they ride together. And thusly from a carpool was created a marriage, formed not in heaven, but in terstate (I-86, in fact). Yessir, them were the days when Minneapolis fandom was just a children's story to those of us on the eastern half of the country (that is to say, east of the Hudson River), that Rick and Asenath and Krissy told to quiet the unruly ones after a late night of story telling and Terminus Dinner Conversation. There were Iron Men in that age, and we will never see their rusted hulks again.

Rick's gone from the Hub of the Universe now (but then so am I), all of these are but memories -- and write-only memories at that. Rick had illustrated Science Digest, Astronomy, newsweek but not Time, a backdrop at WGBH-TV in Boston, the famed starry sky in the main programming tent at Highcon, the legendary '76 worldcon in Highmore, South Dakota, and the cake at the Terminus Halloween party. A couple of years ago, Rick and Asenath left their palatial home in Cornwall Bridge, Connecticut, for Hollywood, where Rick worked on the Walt Disney movie that everyone is still talking about. (Why just a few days ago, Garth Danielson asked me, he said, "Hey, what ever happened to that Disney SF flick that Sternbach was working on?") He's working for JPL now and Asimov's Magazine, and who knows, maybe even waiting for checks from Galaxy, just like everyone else.

Yes boys and girls, this is Rick Sternbach, the man and the myth; now it's up to you to decide which is which.

--David Stever
March, 1979

The 1979 North American Science Fiction Convention
Louisville, Kentucky Aug. 30 - Sept. 3, 1979

NORTHAMERICAN NORTHAMERICAN NORTHAMERICAN NORTHAMERICAN NORTHAMERICAN

FILMS

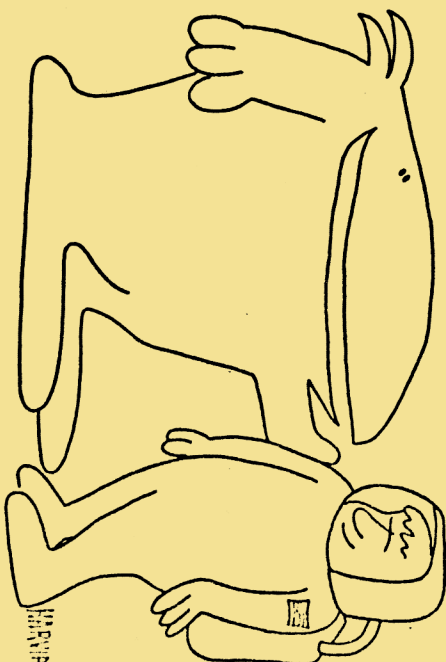

Films will be shown Friday night (beginning at 9:00 pm) and Saturday night (beginning at 10:00 pm) in the Star of the North Hall, Section 2. Look for a sign indicating actual order of showing and approximate starting times outside that room. On Sunday films will be shown in the Gold Room, beginning at noon.

Friday:

(Cartoons) 2 Roadrunner, Popeye, Little Nemo, Superman
(Shorts) The Case of the Mukkinese Battlehorn, Bambi's Revenge, The Dove, Sargeant Swell
(features) The Point, Invasion of the Star Creatures.

Saturday:

(Cartoons) 2 Warner Brothers, 2 Mighty Mouse, 2 Popeye, Betty Boop
(Shorts) Vicious Cycles, Murder by Television, 2002: A Space Odyssey
(features) Sex Madness, Plan 9 From Outer Space

Sunday:

(Features) Transatlantic Tunnel
plus cartoons and shorts by request.

A good word is worth repeating.

Come to the most important event of the science fiction year on this continent! Can't go to Seacon, or want someplace to continue the fun a little longer? Then NorthAmerican is for you. We've planned a wide range of exciting events, topped off by an evening of musical entertainment under the stars on our very own riverboat, the Belle of Louisville. Attending membership in NorthAmerican is \$15.00 until June 30, 1979, and \$20.00 thereafter, so join now and save. To join, or for complete information on the above--and more!--write:

NORTHAMERICAN

P.O. Box 580009

Louisville, KY 40258

THE MASTER OF THE WORLD by Jim Young

My friend Robert E. Vardeman (the "E" stands for "Earth") has long wanted to take over the world. What is most remarkable about him is that he, unlike many others, is actually doing something about it.

I first became acquainted with him through his fanzine Sandworm. Little did I know that Vardebob would start his world-girdling plot through its pages; for early in 1971 he succeeded in confusing the Department of Defense into believing that Sandworm was a journal published by the Sandia Corporation. Sandia is, of course, one of the nation's foremost defense contractors, and a staple of Albuquerque's economy. (The corporation was founded during the First Staple War.) Many people in Washington think that anything with the word "sand" in it must have something to do with Sandia, you see, and this is how Vardeman managed to order three or four surplus nuclear reactors and a Trident submarine C.O.D.

Bob had no trouble selling off the reactors to various fourth world nations -- the Martians have always had lots of plutonium, though very little oil -- but could do little with the submarine. Finally, he was forced to invent a retractable caterpillar track for the thing in order to sell it to the town of Truth or Consequences, New Mexico, as a potential door prize for its annual Bob Barker Festival.

With the proceeds from these sales, he initiated the first large-scale human cloning experiment, creating several hundred clones of himself. These simulacra are often seen

wandering conventions hotels at strange hours of the day or night, and may be detected by following the trails of ice-cubes they leave in hallways. (The clones work by extracting energy from the air, causing them to excrete the ice which condenses around their heat pumps. Very hard at parties, I'd say.) In recent years his clones have been seen in every state of the union, several provinces of Canada, and one of them (serial number Z9M9Z) is currently the mayor of Nogales, Sonora, Mexico.

Since the development of his clones, Vardebob has wrested control of his home-town, Albuquerque, and through a series of edicts he has caused it to become the hot-air ballooning capital of the planet. This has obviated the necessity of employing politicians, a development which has not only drastically reduced the city's property tax levy, but has also helped ease the entire state's balance of trade problem by making hot air a major export. (Note that much of southern Minnesota's summer weather comes from New Mexico courtesy of the jet stream. I've recently started bargaining with Vardeman to get him to make this a winter export as well.)

Vardeman's next move, he says, will be to take over the science fiction publishing industry, a move that will no doubt be aided by his mysterious connections with the super-secret Illuminati organization. He tells me that his next work is guaranteed by his publishers as the largest best-seller since Luke, and its title will be Star Trek 1999: Work and Windy on Battlestar Galactica in the Star War against the Sons of Hercules. True to his arid birth-right, as ever, he says the protagonist of this epic is a girl named Maude Dibb.

Which is reason enough and them some to welcome him to this Minicon as an honored guest!

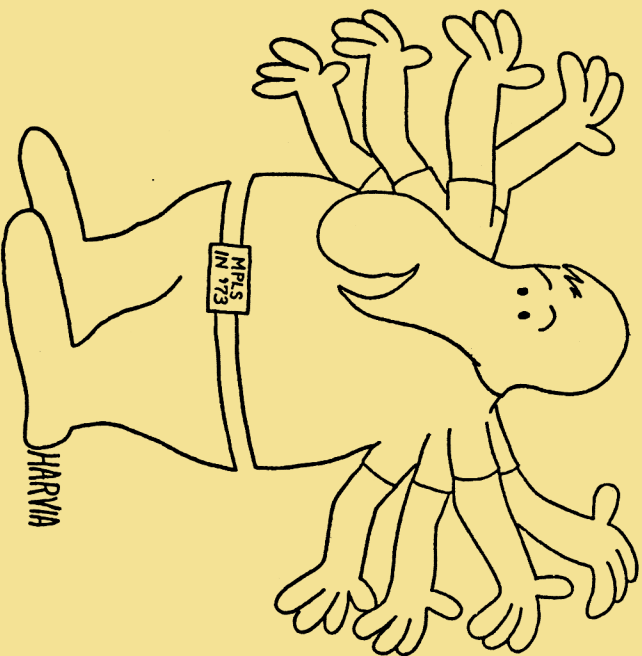

MIMEO ROOM

a fannish method of reproduction other than Bob Tucker.

After getting the obligatory Bob Tucker reproduction joke* out of the way on to business.

The mimeo room has been set up to encourage new fans to enter the world of fanzines (sounds a little pretentious doesn't it) and to offer repro facilities and instruction of same.

* For more information on Bob's amazing Reproductive(TM) abilities stop Bob during the con. He'll be seen smoothing things over. Note: don't touch his bottle and don't interrupt him in a clinch. He'll take the babe first.

30

The room is located in the LaSalle Room C (check your map). Our hours are very flexible, the room will be open most of the time with someone to do the work for you. The Gestetner(TM) 360 Mimeograph and the Gestetner(TM) 455 Electronic Stencil Cutter are only to be used by Mimeo Room Staff. As long as the room is open, there will be some one there to operate the equipment. There will be typewriters to type stencils on, as well as paper to draw on.

FREE; WOW
100 copies of anything you want.

Anyone coming in will be given 2 regular stencils or 1 regular stencil and 1 electrostencil and 100 sheets of paper, printed both sides.

MINICONAPA

Perhaps a little misleading but what the heck. The Apa is open to anyone with 100 copies of a zine and 25¢(not to be spent foolishly). Material should be in by Saturday Midnight. Collation takes place and the night goes on.

Anyone not contributing to the apa can pick one up Sunday for 50¢ should any remain. Proceeds to Taff, Duff and the Better Half Transfer Fund.

Additional materials are available:

Paper	75¢ for 100 sheets
Stencils	\$3,50 per ream.
Electro-stencils	25¢
	75¢

There will be an open discussion type seminar on fanzines and why by fanzine editors and the like, sometime Saturday afternoon. Depends on whom we can round up. Sunday afternoon there will be a seminar on drawing on stencils by Ken Fletcher. Check our posting on the door.

If this sounds very casual, it is and that's the way I want it to be. Nothing serious, just fun with ink and stuff. Bring your crazyness, or your crazy.

31

the COMPLETE Fanzines welcomes you to MINICON 15!

WE HOPE YOU HAVE AN EXCELLENT TIME AT
WHAT SHOULD BE THE FINEST MINICON EVER!!
STOP BY AND SAY HELLO IN THE HUCKSTER ROOM!

NOW IN
PINKYTOWN,
U.S.A.!!

GREG KETTER

RALPH JOHNSON

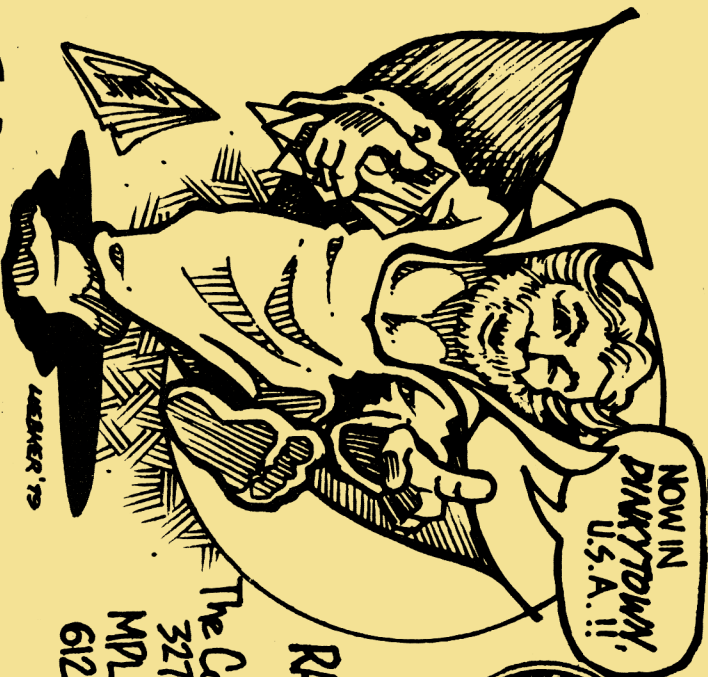

The Compleat Enchanter

327 14TH AVE. S.E.
MPLS., MN. 55414
612-378-2407

The Finest in Science Fiction, Fantasy, Comic Books, & Art!!

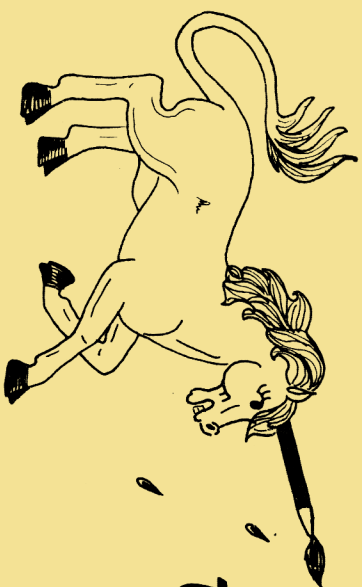

ART

ART AUCTION

This year we're trying something new (Nu? Gnu?). The first person to bid on an item of art, gets to choose (if the person wants to) which auction the piece of art will be auctioned at. There will be an early evening auction (8:30 pm - 9:30 pm Sat.) and a late evening auction (12 midnight-1:30 am) to choose between.

The Sunday afternoon auction (12 NOON-1pm) (All times are approximate) will be reserved for pieces not auctioned off at the first two auctions. This will give you the opportunity, if you have to get into costume to choose the late nite auction, or, if you want to be sure not to miss SEX MADNESS, to choose the earlier auction. If you are not now totally confused, you will have to do so by your own devices. And remember-
ANTIERS OPTIONAL!!!

TAFF DUFF

Taff Duff auction material includes old fanzines! name tags, artwork, books, and t-shirts.

NO PHOTOGRAPHY IS ALLOWED IN THE ARTSHOW or art auction, unless you can furnish indisputable evidence that the artist has granted you permission to photograph his or her artwork.

*Just when you thought
MINNEAPOLIS was
SAFE...*

**FILLMORE
MIDWEST**



**GARY
DANIELSON
JOE WESSON**

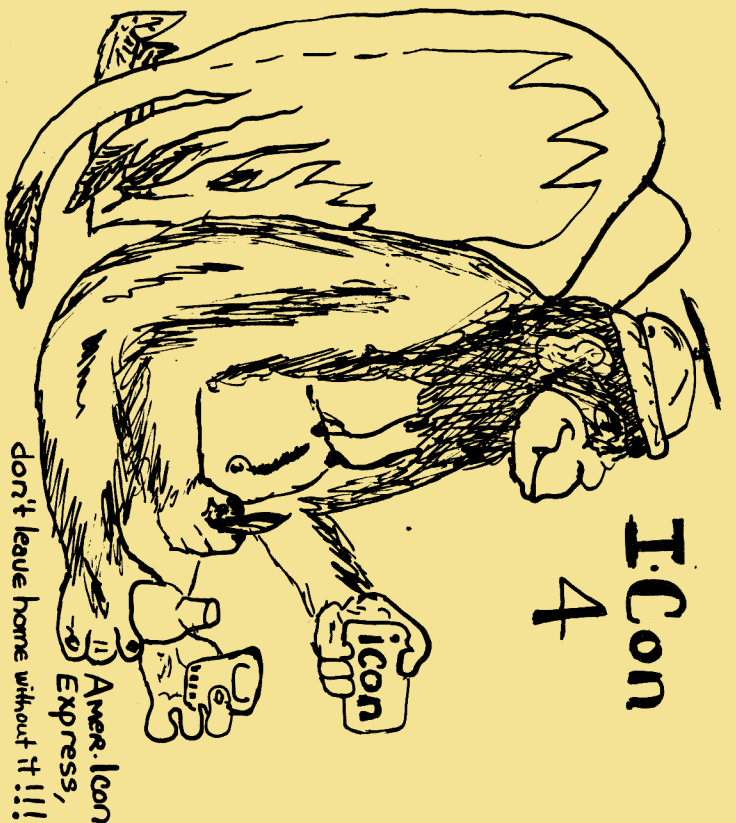

**I:Con
4**

don't leave home without it!!!

the new improved I:Con IV

9-11 November '79

Coachman Inn
Iowa City, IA 52241
(319) 645-2940

Bargain Rooms Limited
Please reserve early

\$15 Lone Friend \$19
\$25 Really Friendly

FIILMS, PROS, FEN
HOSPITALITY SUITE,
WIKKSTING, Con*TESTS

Special Guest Speaker: Dr. James Van Allen

I-Con IV c/o G.Kay Hinchliffe
Rt.#3 Cedar Rapids, IA 52401 (319) 895-8928

REGISTRATION:
\$7 til 26 Oct.
\$9 thereafter

Huxsters:
\$10 full table
\$7 half table

c/o Rusty Hevelin
3023 Old Troy Pike
Dayton, OH 45404
(513) 236-0728



Ambrov
Zeor

presents

"Sime Surgeon"

by

Jacqueline
Lichtenberg

author of

"House of Zeor" +

"Unto Zeor Forever"

from *Sunderday*, *Rebelleaks* &
Playboy *Novels*

Issues #4, #5, #6, #7 & #8 are now
available

contact Ambrov Zeor c/o Anne Golar
P.O. Box 290, Monsey, N.Y. 10952



ATTEMPTACON 4 COULIE CON 2

October 26-28, 1979 • LaCrosse, WI

GoH: A.E. Van Vogt
Fan GoH: Mike Gliecksohn

Art GoH: Jim Odbert

EVENTS

- Art show and book displays
- Saturday night masquerade party
- Riverboat tour (if enough interest is shown)
- Movie classics like "Nosferato" and "Phantom of the Opera"
- UW-L Planetarium program
- Weekend wargames and dungeon-ing
- Day clam hunting on the Mississippi
- Panels, lectures, speeches, and other gentalia

INFORMATION

Membership:
\$10⁰⁰ - Preregistered
(Banquet included)
\$8⁰⁰ - At the door (No Banquet)

\$15⁰⁰ - Huckster table for weekend
(includes membership and
banquet)

Write: ATTEMPTACON 4
c/o Robin Jenkins
811 Johnson St.
LaCrosse, WI 54601
or call (608)784-8751
or (715)834-7168

Motel Rates:

Before Oct. 1 \$24⁰⁰ Single
\$28⁰⁰ Double
After Oct. 1 \$28⁰⁰ Single
\$34⁰⁰ Double

Rooms must be reserved by Oct. 1
for con rates (sorry, we tried).

Write - Ramada Inn
2325 Bainbridge Road
LaCrosse, WI 54601

XCON '79

July 6-8 Milwaukee

Holiday Inn Central



"And they say we don't exist!"

ProGson: Kelly & Polly Freas
Fon Gof: Doug Price

Registration: \$6.50 til June 15 \$9 after

For information, write: X-Con '79

3942 S. Tara Hill DR.
Greenfield, WI 53220

CON COM LIST FOR MINICON 15

EXECUTIVE COMMITTEE: Carol Anndy, Don Bailey,
Bev Elmshauser, Scott Imes, Dave Wixon.

ART AUCTION: Rick Gellman, Blas Mazzeo
ART SHOW: Richard Fatge, Shelby Hockert,
Cat Ocel

BANQUET: Ann Isenberg
BIBLIOGRAPHY: Denny Lien
BOOK: Scott Imes, M. Beth Komor, Stuart
A. Wells III, Jim Odbert

COMPUTERS: Dean Gahlon, John Stanley, Brian
Westley

FILMS: Lee Pelton, Page Ringstrom, John
Purcell

GOPHERS: Don Bailey, Martin Schafer,
Assistant Grandfather Gopher
John Stanley.

HOTEL LIASON: Dave Wixon, Caryl Wixon
HUCKSTERS: Denny Lien, Greg Ketter

MASQUERADE: David Emerson

MIMEO ROOM: Garth Danielson, Joyce Scrivner
Jerry Stearns, Keith Hauer-Lowe,
Greg Ketter, Eileen Maloney

PARTIES: Greg Ketter, Eileen Maloney

PROGRAMMING: David Emerson, M.K. Digre, Mark
Richards, Dave Romm

PUBLICATIONS: Ken Fletcher, John Bartelt,
Karen Johnson, Garth Danielson,
Kathy Marschall, Larry Becker,
Edgar Rice Gerbill

RECORDER: Pamela Dean

REGISTRATION: Bev Elmshauser, Doug Friaaf, Karen
Johnson

RESTAURANT

GUIDE: David Dyer-Bennet
SECURITY: David Dyer-Bennet, Michael Butler

TREASURER: Carol Anndy, Blas Mazzeo
T-SHIRTS: Rick Gellman

VIDEO: Ben Lessinger, Scott Imes, Gary
Sissala, Alex Gav, Bruce Fagrie

AND MORE STAFF: Margie Lessinger, Steve Glen-
non, Louie Spooner, Lynn Ander-
son, Steve Bond, Steve Elmshauser, Elizabeth
Lavelle, Bill Dixon, Gayle Dixon, Vera Matich

THE OTHER TEN PERCENT



MPLS IN '73

DON'T DREAM IT DO IT

THE OTHER TEN PERCENT?

© 1970 SWICK