

PASSPORT TO THE UNIVERSE



THE SEQUEL

CONADIAN

52ND WORLD SCIENCE FICTION CONVENTION

QUICK REFERENCE GUIDE

SEPTEMBER 1-5, 1994

WINNIPEG, MANITOBA

Your Guide to the Guide

The main purpose of the Quick Reference Guide is to provide you with information on daily ConAdian Programming as well as useful information on the city of Winnipeg and its services.

The coloured pages in the center of the book are a pull out section. Each day's programming is provided on a different coloured sheet and all you need to do is carry the daily page with you (along with your passport). The daily newszine will be printed on the same colour paper as the daily programming.

Thursday - Gold	Sunday - Blue
Friday - Pink	Monday - Yellow
Saturday - Green	

INDEX

<p>Maps - Convention Centre Main Floor.....3 - Convention Centre 2nd & 3rd Floor.....4 - City of Winnipeg Downtown Map.....5</p> <p>Time and Time Again - Art Auction6 - Art Show6 - Blood Drive6 - Childcare6 - Con. Ops6 - Con Suite6 - Dealers Room6 - Exhibits6 - Events6 - Extravaganzas.....6 - Fan Auction.....7 - Fan Tables.....7 - Fanzine Room7 - Filking.....7 - Green Room.....7 - Gopher Hole.....7 - Handicap / Access.....7 - Information Booth.....7 - Kidcon.....7 - Masquerade Registration.....7 - Medical.....7 - Newszine.....7 - Registration8 - Sales to Members.....8 - Staff Room.....8 - WSFS Business Meeting.....8 - WSFS Site Selection8</p> <p>Policies - Alcohol.....8 - Badges.....8 - Lost Badges.....8 - Non-Humans.....8 - Other Stuff.....8 - Smoking.....8 - Volunteering.....8 - Weapons.....8</p> <p>British Videos.....9 & 10</p>	<p>The Science Channel.....11</p> <p>Japanese Videos.....13</p> <p>Gaming.....14</p> <p>Filk Programming.....15</p> <p>General Program Info.....16</p> <p>Program Room Locations.....16</p> <p>Programming17</p> <p>Participants List.....24</p> <p>Daily Programming Schedules.....INSERTS</p> <p>Dealers - Dealers Map.....31</p> <p>Videos / Film Program.....32</p> <p>Artist Participant List32</p> <p>Tips and Tricks32</p> <p>City Guide Section - TheNumbersGame.....33 - Duty Free or Pay the GST.....33 - Parking and Transport.....33</p> <p>Things to Do and See in Winnipeg.....34</p> <p>Religious Services.....35</p> <p>Dining.....35</p> <p>Out on the Town.....35</p> <p>Services - Banks, Bookstores, Computer Stores, Gas Stations, Copy Shops, Costumers Supplies, Grocery Stores, Liquor Stores, Pharmacies, Stationary & Office Supplies 36</p>
---	---

CONVENTION CENTRE MAIN FLOOR MAP

YORK AVENUE

CARLTON STREET

EDMONTON STREET

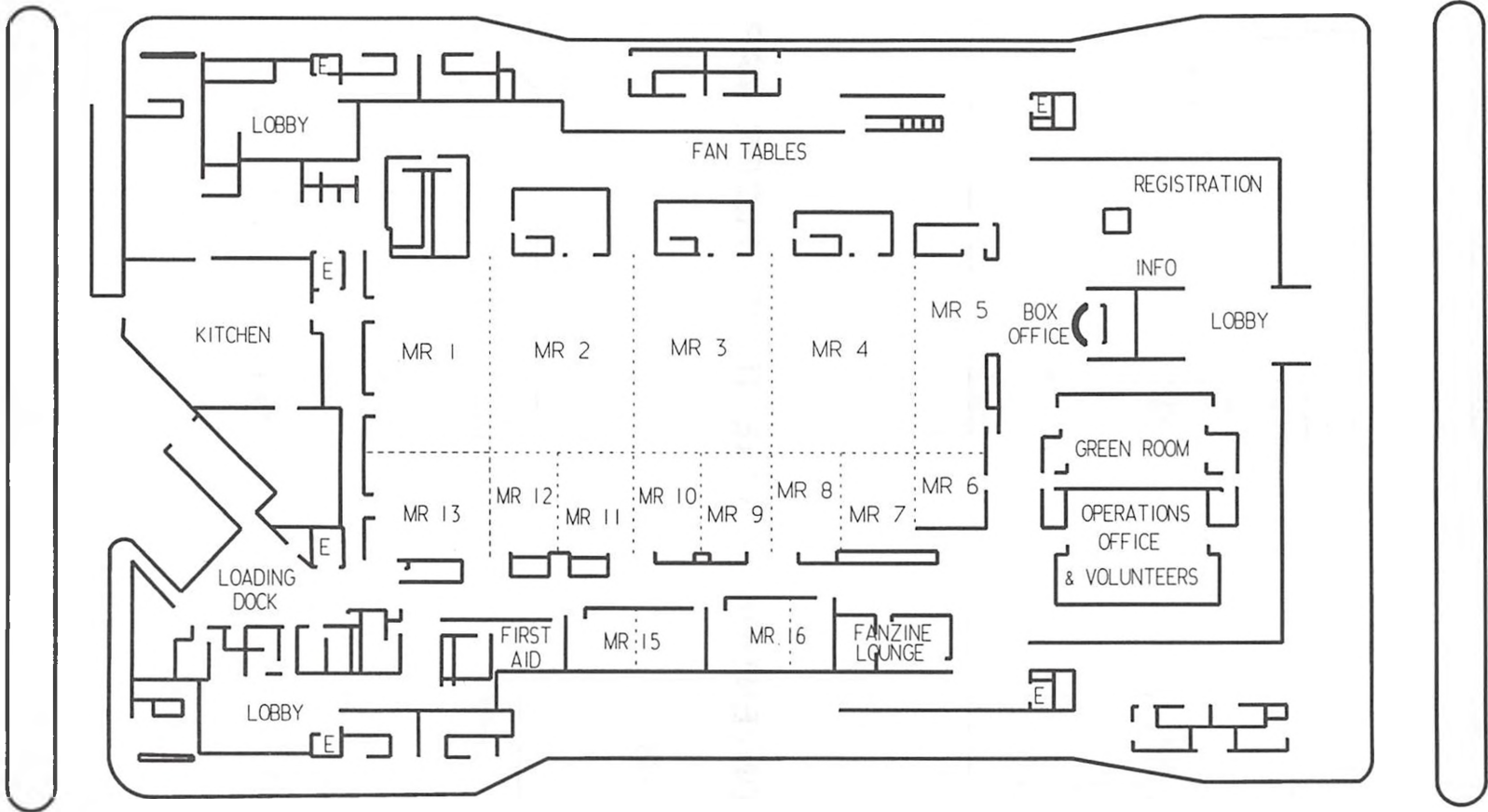

ST. MARY AVE

CONVENTION CENTRE SECOND FLOOR MAP

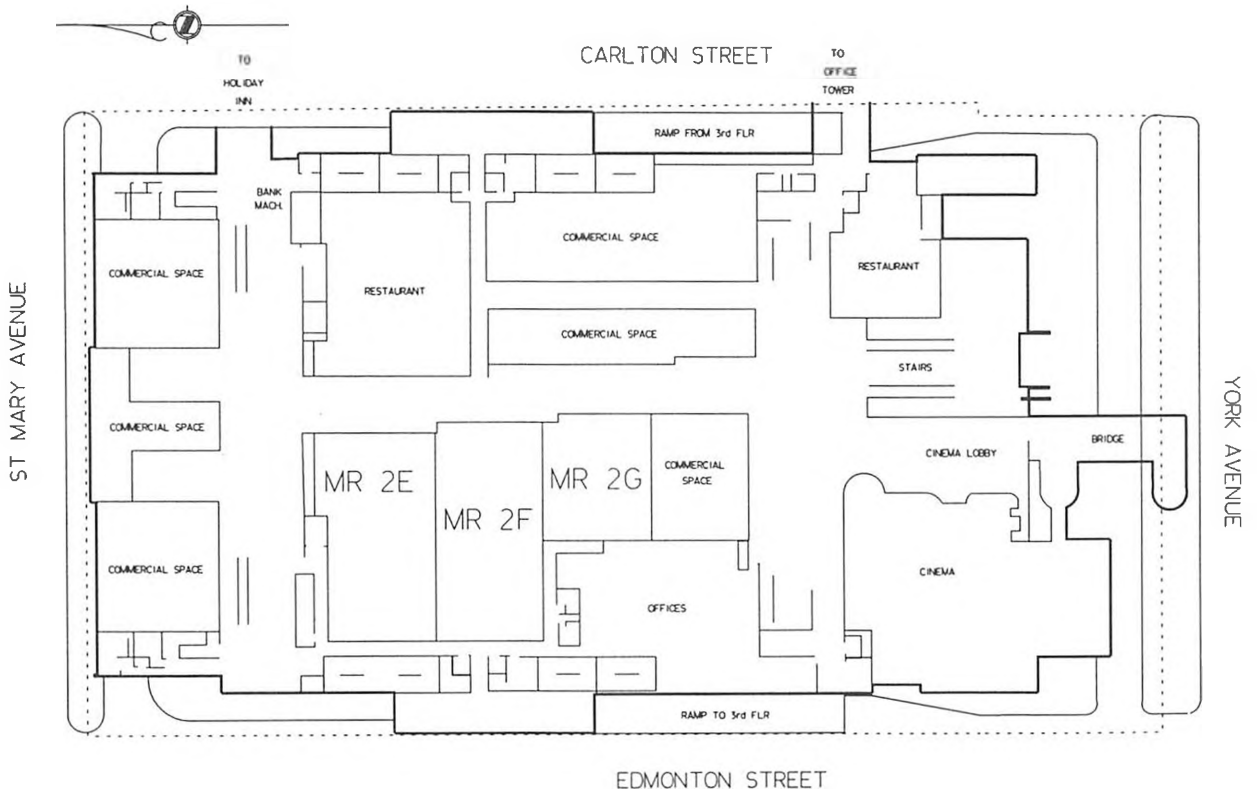

CONVENTION CENTRE THIRD FLOOR MAP

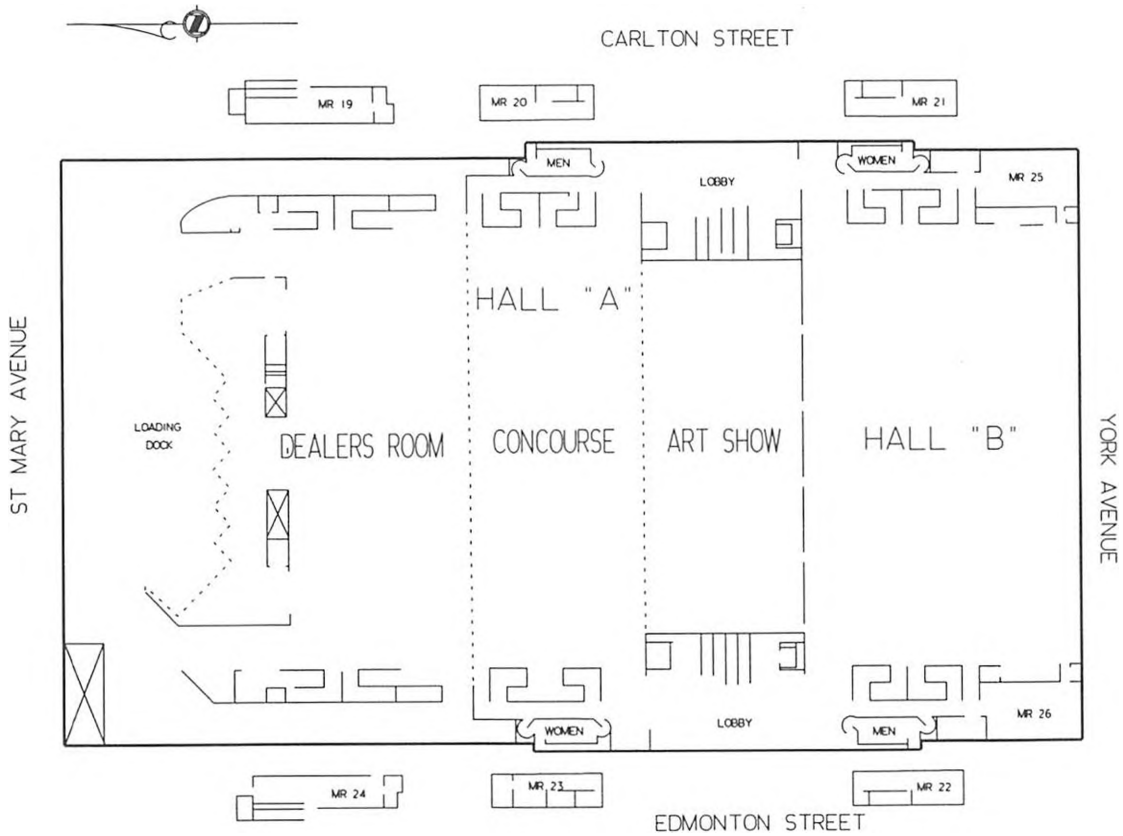

DOWNTOWN WINNIPEG MAP

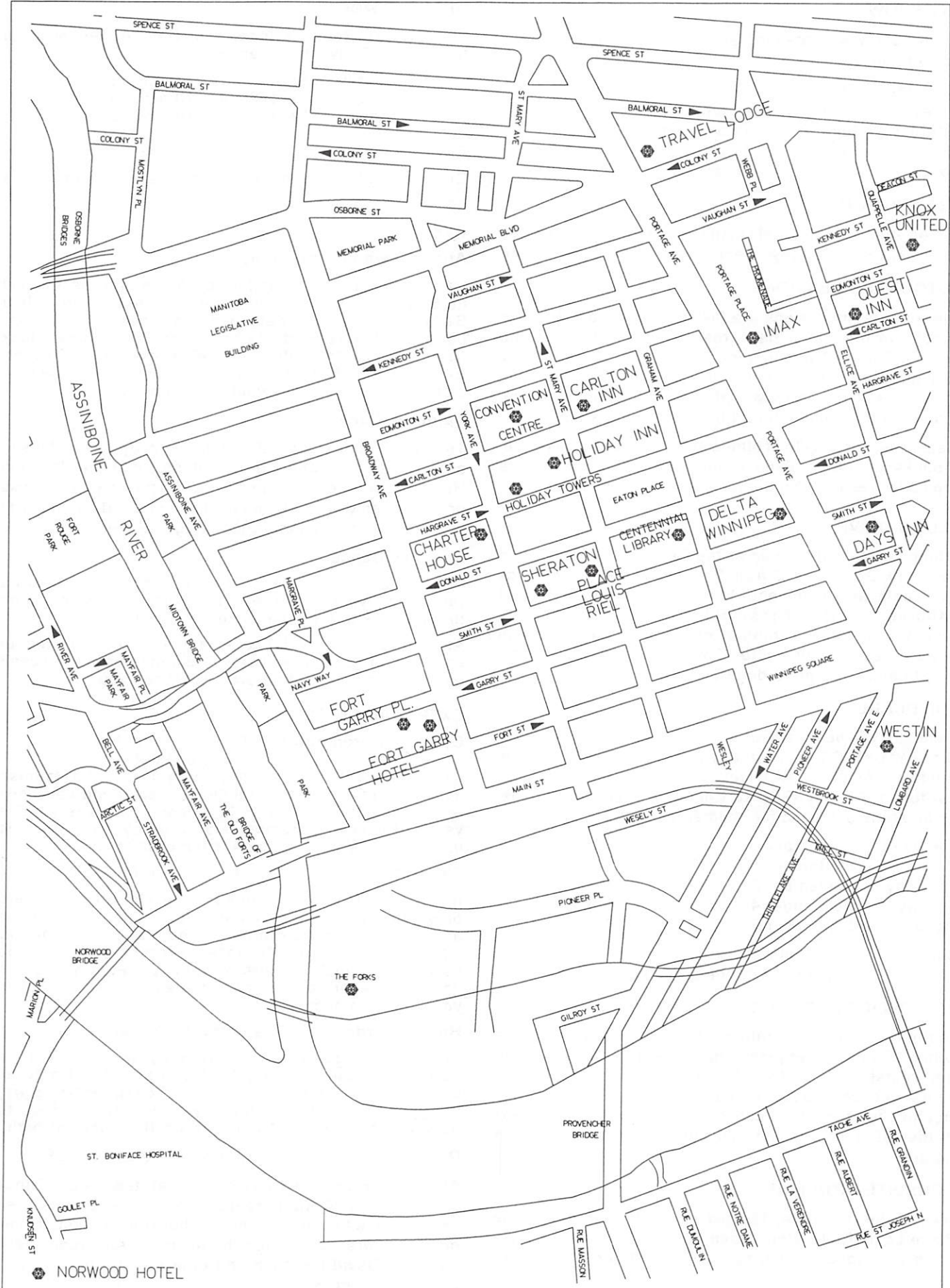

TIME AND TIME AGAIN

ART SHOW

The Art show is located in Hall "A" on the third floor of the Convention Centre

Thursday	Sept. 1	12 pm - 7 pm
Friday	Sept. 2	11 am - 7 pm
Saturday	Sept. 3	11 am - 7 pm
Sunday	Sept. 4	11 am - 2 pm 6 pm - 8 pm
Monday	Sept. 5	9 am - 3 pm

ART AUCTION

The Art Auction will be held in the area immediately beside the art show on Sunday, September 4 from 2 pm - 4 pm.

AUTOGRAPH SESSIONS

The Autograph sessions are taking place Friday through Sunday in the Concourse area near the Art Show and Dealers Room. The number of books you can bring may be limited by each author. Presently the only limit we know of is 2 for Anne McCaffrey... other limits will be posted on the bulletin board by the session area.

Please be considerate of others and do not bring boxes full of books for autographing by one author, or bring multiple copies for resale. We appreciate your cooperation.

BLOOD DRIVE

A blood drive will be held at the Red Cross building on Saturday, September 3 from 9 am - 5 pm. A van will pick up people at 10 am and 11 am to take them to 226 Osborne N. (Red Cross Building). Maps will be available at the information desk for those who wish to walk. Bring your photo ID with you and don't forget to eat before you go to donate blood.

CHILDCARE

Childcare will be off site at Knox Day Nursery, (over flow at the YM-YWCA on Thursday and Friday). A bus to the childcare facilities will leave from the Best Western Carlton Inn 15 min BEFORE Childcare opens and closes. Childcare is designed for children aged 2-6.

Thursday	September 1	1 pm - 6:15 pm
Friday	September 2	9 am - 6:15 pm
Saturday	September 3	9 am - 6:15 pm
Sunday	September 4	9 am - 6:15 pm
Monday	September 5	9 am - 4:30 pm

Note: Lunch and snacks will be provided.
Supper will not be provided

CON OFFICE / CON OPS

Lost child? Pre-registration? Severe confusion?? The Office handles emergency situations and some pre-con (ie: registration before ConAdian starts) and after hours services. Security operates out of Con Ops. The location for the office/con ops are rooms 17/18, next to the VIP room, in the main lobby of the Convention Centre.

CONSULTE KON-IVAL

We are the consuite, located in the Riel Room in the Place Louis Riel Hotel. Open 10 am - 2 pm and 4 pm - 4 am with special features daily. Come one come all!!

DEALERS ROOM

The Dealers Room is located in Hall "A" on the third floor of the Convention Centre.

Thursday	Sept. 1	12 pm - 6 pm
Fri. - Sun	Sept. 2 - 4	10 am - 6 pm
Monday	Sept. 5	10 am - 3 pm

EXHIBITS

Exhibits are located in Hall "A" on the third floor of the Convention Centre.

EVENTS

Aurora Awards Ceremony

Canadian Awards, similar to Hugos, for best novel in English / French, short story, fanzine, etc. Held Saturday, September 3rd, at the Centennial Library (2 blocks East of Convention Centre, one block North) 3-5 pm. This will be an all-Canadian, all-star event. Expected are Marc Garneau, Judy Merrill, R.S. Sawyer and so many more you wouldn't believe it!

Spider's Place

Thursday, 8pm Norwood Hotel. Join Spider Robinson as he hosts an evening of nonfolk music at the Norwood Hotel. Join other fans and pro's as they try to impress one another with their musical talent. Participants will play half-hour sets before jamming together.

Regency Dance

Friday MR 1 8:30pm, The English Regency period (about the year 1800) was a colorful, whimsical time that appeals to the fannish sense of humor.

At ConAdian we'll dance Friday evening. Come in costume, or come as you are. And don't worry if you can't dance. Our host, John Hertz, will teach you.

EXTRAVAGANZAS

Opening Ceremonies Thursday, 2pm Hall B
Doors open at 1 pm

ConAdian will host a show with local and fannish activities, including the traditional welcoming speeches and introductions. Barry B. Longyear serves as this year's Master of Ceremonies so drop by and welcome in the 52nd World Science Fiction Convention.

The Gather Friday, 7:30 pm Rm2EFG

In honour of guest-of-honour Anne McCaffrey, we are presenting a Pernese Gather with dragon decorations and a variety of performers and dancers in proper Pernese tradition. Pernese refreshments will be served to guests. There will be prizes awarded in various categories relevant to the evening - so dress in your finest costumes.

Hugo Awards Saturday, 8 pm Hall B

The 41st Hugo Awards Ceremony will be held on Saturday, September 3rd, 1994 at 8 pm. The Master of Ceremonies will be ConAdian's Toastmaster, Barry Longyear. All ConAdian members are invited to attend to honour the Nominees on their special night.

Rock Dance Saturday, 10:30 pm Rm2EFG

After the Hugo awards join us at the Rock Dance sponsored by Warner Books who are celebrating their new science fiction line which debuts this August. Come meet authors, C.J. Cherryh, Kevin J. Anderson, Jane Fancher, David Feintuch and others....they'll give away prizes, free books and more!

Masquerade Sunday, 8pm Hall B
Doors open at 7:30 pm

The Masquerade is always the most spectacular venue at Worldcon and this year will be no exception.

Closing Ceremonies Monday, 1 pm Hall B

Closing Ceremonies will be held on Monday afternoon. Please join with us in saying goodbye to the 52nd. Worldcon and welcome to **Intersection**, the 53rd.

FAN AUCTION

Rare books, publishers' proofs, unusual periodicals, t-shirts, posters, strange objects, exotic paraphernalia, and a few surprises will come under the hammer at the Benefit Auction, at noon on Friday September 2nd. Items sold will aid such causes as the Science Fiction Foundation, the Down Under Fan Fund, and the Trans-Atlantic Fan Fund.

Auctioneers include Mike Resnick, Joe Haldeman, and Jack Chalker, so you will be entertained while we relieve you of your money...all in a good cause. Bring your friends, relatives, fans, and (most importantly) your wallet. We can accept credit cards for large purchases.

Some of the items to be auctioned will be on display in the Art Show until just before the auction.

FAN TABLES

The Fan Table area is located on the main floor of the Convention Centre near the main entrance.

FANZINE LOUNGE

The Fanzine Lounge is located on the main floor of the Convention Centre next to meeting Room #16.

FILKING

The following daytime filk events were confirmed at press time. Check postings outside the filk rooms, or with Dave Clement at the Filk Office (Campaign Room North on the Holiday Inn second floor), for up-to-the-minute info.

Filk Sampler Concert Saturday afternoon ... 12 noon
Sample from a variety of performers, subjects, and styles. 15-minute sets aimed at the "mainstream" F & SF audience; schedule of performers will be posted outside the Filk Performance Room. Filkers, sign up at the Filk Office for your 15 minutes of fame!

Anne McCaffrey Concert Sunday afternoon ... 12 noon
Music celebrating ConAdian's GOH, her works and her worlds. Confirmed performers include Kathy Mar, Diane and Sylvia Sing, and Andrea Yeomans.

GOPHER HOLE

If you put in your 4 hrs of volunteering, at con, then you may come visit us in the volunteer suite. We are located on the 3rd floor of the Carlton Inn.

GREEN ROOM

A quiet place for guests and panelists to get away from it all. We're situated in the lovely VIP lounge on the first floor of the Convention Centre. We have couches, comfy chairs, tea, coffee, muffins and the like. Hours: 9AM - 7PM

HANDICAP / ACCESS

We will be located near registration on the main floor of the Convention Centre. Please come see us if you need EXTRA HELP GETTING AROUND THE CON. Please come half an hour before the program to get your Pre-Assigned Seating. Our Hours Are: Thursday to Monday 10 a.m. - 7:30 p.m.

INFORMATION BOOTH

The ConAdian information booth will be located on the main floor of the Convention Centre, beside the escalators, near registration.

KAFFEEKLATSCH

The KaffeKlatsch sessions are taking place in meeting room #5 Friday through Sunday of the convention. These are informal discussions with program participants. (authors, artists, scientists and others) who we think you may wish to chat with.

We have round tables seating 10, set up for each participant and have coffee/tea service set up in the room. Pre-registration is required at the Con information desk (limit of 10 per participant) Hope to see you there.

KIDCON

Kidcon will have on-site activities everyday for young fans aged 6-14. These activities will be held in the basement of the Best Western Carlton Inn (Carlton room).

Thursday	Sept. 1	2 pm - 6pm
Friday	Sept. 2	10 am - 1 pm 2 pm - 6 pm
Saturday	Sept. 3	10 am - 1 pm 2 pm - 6 pm
Sunday	Sept. 4	10 am - 1 pm 2 pm - 6 pm
Monday	Sept. 5	10 am - 2 pm

Snacks will be provided, lunch and supper will NOT be provided. Kidcon will be CLOSED between 1 p.m. - 2 p.m. Friday - Sunday. Evening movies will happen in the Best Western Carlton Inn Friday- Sunday from 7 pm - 2 am. There will be 2 rooms - one for older and one for younger children. Minimum age for the movies is 4 years old. Kidcon will also be running field trips on Friday, Saturday and Sunday.

MASQUERADE REGISTRATION

Entry forms will be accepted at the Masquerade desk at ConAdian up to Friday evening at 8:00 p.m.

MEDICAL - ST. JOHNS AMBULANCE

We are providing medical/first aid services during ConAdian. We are in room MR14 on the first floor on the Convention Centre. Our services are provided free of charge to anyone who comes in. We also will have personnel on site with their own first aid kits. Feel free to approach any of them if you have a problem. Take care, and have a safe con.

NEWSZINE "VOYAGEUR"

The Voyageur will be available twice daily. It will be on the stands every morning by 10 am and every evening by 5 pm. Submission can be dropped off at the Con Suite, Information Booth and the Newszine office. Daily submission deadlines are 10 a.m. and 3 p.m. No submission will be accepted without valid identification (name and badge # will be accredited in the daily paper). We reserve the right to edit all submissions.

REGISTRATION

Registration will be setup on the main floor of the Convention Centre near the main entrance.

SALES TO MEMBERS

Sales to Members operate a booth near Registration in the main lobby of the Convention Centre. Hours are 10 am - 6 pm. We will offer a variety of unique items, traditional items, and uniquely traditional items. Take your pick! (and the items are so inexpensive we don't know how we did it!)

STAFF ROOM

Welcome to the staff lounge. Located in the Carlton Inn, right across from the Convention Centre. Our room is in the basement - Salon B. We will provide a quiet place for all Worldcon Dept. staff to relax and eat some healthy food.

WSFS - Business Meetings

The World Science Fiction Society will be holding their annual business meetings during the convention. Please refer to Programming for times and locations. All members of ConAdian are welcome to attend.

WSFS - 1997 Site Selection

1997 Worldcon Site Selection Site selection is where members of ConAdian vote on where the 1997 World Science Fiction Convention will be held. All attending (and supporting) members of ConAdian may vote. (Single-day and other membership classes may not vote, however). Cast your ballot at the "Box Office" located on the ground floor of the Convention Centre. Results of the election will be announced at the WSFS Business Meeting at Noon on Sunday.

Thursday	September 1	2 pm - 6 pm
Friday	September 2	10 am - 6 pm
Saturday	September 3	10 am - 6 pm

POLICIES

ALCOHOL

Drinking and driving are serious offences in Manitoba. Have a designated (non-drinking) driver, take a cab or stay in the hotel. Blood alcohol level of .08 is considered "under the influence" by Manitoba Law. The legal drinking age in Manitoba is 18. If necessary, check ID's at parties.

BADGES

Wear your badge at all times. Many of the function rooms and events will have people checking badges at the door. The convention center security staff have been instructed to check badges as well.

LOST BADGES

A replacement badge is available at Registration. You will be charged the Full Membership Rate for a replacement badge. If you locate your lost badge, a refund is available at registration minus a \$10 handling fee. So don't lose your badge !!!

NON - HUMAN POLICY

All Non-Human members must be accompanied by a human member at all times .

OTHER STUFF

ConAdian reserves the right to revoke or refuse convention membership and expel any member for cause.

SMOKING

The Convention Centre and Con Suite facilities are non-smoking. Make sure you check the smoking / non-smoking areas in all hotel facilities. Many restaurants, stores and shopping malls are non-smoking. Be sure to look for the designated smoking areas before lighting up. Hospitality groups should make note of their smoking status when promoting their hospitality suites/ rooms.

VOLUNTEERING

Yes, please. From Chairman to the person behind the registration desk, to the persons checking badges on doors, we are all volunteers. A Volunteer booth has been set up on the main floor of the Winnipeg Convention Centre, and if you wish to help this convention even if only for a short time, please join us in creating a good convention.

May we also remind you that for each four hours worked at the convention, you will receive a ticket for a draw at closing ceremonies. The draw is for an airline ticket to, and a membership in, the 1995 WorldCon in Glasgow, Scotland. Volunteers who have worked 12 hours at the convention will receive a free Volunteer T-Shirt.

WEAPONS

No real or real-looking weapons will be allowed in the public areas of the convention. Check with the Masque Director for the specific rules pertaining to weapons at the Masque.

Weapons purchased in the Dealers Room must be wrapped and returned to your hotel room immediately.

The determination of what is a weapon shall be made by the committee and all such decisions are final.

If you are informed that you are in conflict with the weapons policy, you will be allowed to return to your room to remove the offending item. Should you fail to do so, Operations will request you hand in the item for safe-keeping until the end of the convention when it will be returned to you. The only exception to the above shall be in the case of real weapons. If anyone is found with a real weapon that violates the laws of Winnipeg or Canada, Operations will summon the local constabulary to deal with the matter.

(*Do, please, take the time to learn the laws of Canada and Winnipeg with regard to firearms particularly. The committee would hate to see your vacation in Canada ruined by your deportation.*)

BRITISH VIDEO PROGRAM SCHEDULE

LOCATION : CHARTER HOUSE HOTEL 3RD FLOOR

THURSDAY P.M. British Video

12:00	Quatermass
15:25	Biggles - Biggies Adventure in Time
17:00	Faulty Towers - The Wedding Party
17:35	Captain Scarlet
19:25	Music-A-Grams
19:40	Grim Tales
20:30	Palace
21:30	Ripping Yarns
22:30	"This Is David Lander"
23:30	Star Cops

17:00	Dr. Who - Dimensions In Time
17:15	Thirty Years Inside The Tardis
18:05	Red Dwarf 6 - Psirens
18:35	Red Dwarf 6 - Legion
19:00	Red Dwarf 6 - Gunman Of The Apocalypse
19:30	Red Dwarf 6 - Emohawk Polymorph 2
20:00	Red Dwarf 6 - Rimmer World
20:30	Red Dwarf 6 - Out Of Time
21:00	The Avengers, Epi "The Frighteners"
22:00	The 10%er's
22:20	The Making Of HitchHikers Guide To The Galaxy
23:20	The New Statesman

FRIDAY A.M. British Video

00:10	Blakes 7
01:00	Black Adder 3 - "Sense & Senility"
01:27	Mr. Bean - The Curse of Mr. Bean
02:20	Spitting Image - Marathon
04:25	Sapphire and Steel - Adventures of 3
06:55	The Young Ones
08:00	The Stranger Series - In Memory Alone
08:45	English Express
09:00	Dr. Who - Dimensions In Time
09:15	Thirty Years Inside The Tardis
10:05	Red Dwarf 6 - Psirens
10:35	Red Dwarf 6 - Legion
11:00	Red Dwarf 6 - Gunman Of The Apocalypse
11:30	Red Dwarf 6 - Emohawk Polymorph 2

SUNDAY A.M. British Video

01:00	"Stuff" with Alexi Sales
02:50	The Harry Enfield Television Program
04:45	The Lenny Henry Show
05:15	Sherlock Holmes - The Blue Carbunkel
06:00	Doctor Who - Daleks, The Early Years
07:50	Sherlock Holmes - The Three Gables
09:00	Faulty Towers - The Wedding Party
09:35	Captain Scarlet
11:25	Music-A-Grams
11:40	Grim Tales

FRIDAY P.M. British Video

12:00	Red Dwarf 6 - Rimmer World
12:30	Red Dwarf 6 - Out Of Time
13:00	The Avengers, Epi "The Frighteners"
14:00	The 10%er's
14:20	The Making Of HitchHikers Guide To The Galaxy
15:20	The New Statesman
17:00	Comic Strip Presents Space Women
17:30	Cyber Zone
18:05	Arcadia
18:15	Sherlock Holmes - Eligible Bachelor
20:00	Sherlock Homes - The Last Vampire
21:45	The Stranger Series - Summoned By Shadows
22:20	Biggles - The Adventures of Space and Time



SUNDAY P.M. British Video

12:30	Palace
13:30	Ripping Yarns
14:30	"This Is David Lander"
15:30	Star Cops
16:10	Blakes 7
17:00	The Mary Whitehouse Experiences, 6 of this Series
20:00	Selling Hitler - Mini Comedy Series

SATURDAY A.M. British Video

00:00	Bottoms - Episode "Smile"
00:25	Bottoms - Episode "Gas"
01:00	The Mary Whitehouse Experiences, 6 of this Series
04:00	Selling Hitler - Mini Comedy Series
08:15	Faulty Towers - Blotter
09:00	Police
10:20	A Very Polish Practice

MONDAY A.M. British Video

00:15	Faulty Towers - Blotter
01:00	Black Adder 3 - "Sense & Senility"
01:27	Mr. Bean - The Curse of Mr. Bean
02:20	Spitting Image - Marathon
04:25	Sapphire and Steel - Adventures of 3
06:55	The Young Ones
08:00	The Stranger Series - In Memory Alone
08:45	English Express
09:00	Quatermass

SATURDAY P.M. British Video

12:20	The Stranger Series - More Than A Messiah
13:00	Waiting For God
13:30	Prisoner - Chimes of Big Ben
15:15	Comic Relief
16:30	Black Adder 2 - "Beer"

MONDAY P.M. British Video

12:25	Biggles - Biggles Adventures in Time
14:05	END OF PRESENTATION

BRITISH VIDEOS ... ALPHABETICAL LISTING

Arcadia - A comedy drama where the world is controlled by video games and people let this take over their non-game behavior. , Fri 18:05

A Very Polish Practice - A continuation of the story of A Very Peculiar Practice, starring Peter Davison. Now moved to Poland family and all, his adventures continue. , Sat 10:20

Biggles - Biggles Adventures in Time Biggles, a man with an extraordinary personal defense mechanism, when the moment of imminent death occurs he "lime hops" from the 80's to the trenches of World War 1 (and back again). , Thur 15:25, Fri 22:20, Mon 12:25

Black Adder 2 - "Beer" What do you do when the relatives come visiting when you are trying to have a party?, Sat 16:30

Black Adder - "Sense and Senility" Is the world gone nuts or are you going senile? , Fri 01:00, Mon 01:00

Blake 7 - Good versus evil set in the future aboard the spaceship Liberator. , Fri 00:10, Sun 16:10

Bottoms - Episode "Smile" The Adventures of a very odd couple. Craig Charles and a friend from The Young Ones star in this comedy of two young chaps sharing an apartment. Clean British humour. , Sat 00:01

Bottoms - Episode "Gas" Another humorous adventure of these two crazy flatmate's! , Sat 00:25

Captain Scarlet vs The Mysterons - Gerry Anderson's puppet show of futuristic cops, who battle against the Mysterons from Mars, who plan to destroy the Earth. , Thur 17:35, Sun 09:35

Comic Relief - A series of shows done by British comics to raise money for children in need. , Sat 15:15

Comic Strip Presents Space Women - A spoof on James Bond by Henry Enfield, Alexi Sales, and co. , Fri 17:00

Cyber Zone - Red Dwarf's Craig Charles created and hosts this Virtually Reality British game show. When contestants move, their computer generated bodies, do all the action on the monitor. Clean general family fun., Fri 17:30

Dr. Who - "Daleks, The Early Years" A look back at the history of the Daleks in the early years of this classic BBC science fiction adventure. Includes previously aired footage thought lost and found recently in the back of the BBC vaults. , Sun 06:00

Dr. Who - "Dimensions In Time" - The 30th Anniversary special features all the remaining living Doctors! , Fri 09:00, Sat 17:00

English Express - This show about words, starring Craig Charles of Red Dwarf, shows us how to properly use the English Vocabulary, educational. , Fri 08:45, Mon 08:45

Faulty Towers - "Blotter" - The Premier The very first episode of this wacky spoof of the running of an English Countryside hotel, in which nothing goes right. , Sat 08:15, Mon 00:15

Faulty Towers - "The Wedding Party" A wedding with a difference, Basil Do You Mind??, Sorry Dear?? , Thur 17:00, Sun 09:00

Grim Tales - The famous short stories read by Rick Mao accompanying the visuals by Jim Henson (cartoon style experimental animation). , Thur 19:40, Sun 11:40

Mr. Bean - "The Curse of Mr. Bean" Rowen Atkinson brings back the era of the silent slap stick films with his portrayal of a stumbling nobody who just can't get it right. , Fri 01:27, Mon 01:27

Music-A Gram - A show about music starring Sophie Atwood., Thur 19:25, Sun 11:25

Palace - A comical look at the British Royal Family., Thur 20:30, Sun 12:30

Police - A drama set in working class England focusing on children learning about right and wrong. , Sat 09:00

Prisoner - "Chimes of Big Ben " 2nd show of the series, the Prisoner matches wits with the most famous No. 2 of them all., Sat 13:30

Quatermass - " Vintage" scientists try to fight off Aliens who are abducting the Earth's children. Last of the series. , Thur 12:00, Mon 09:00

Red Dwarf 6 - "Psirens" Lister and crew get into trouble with Psirens when they take StarBug on a short cut through an asteroid field while chasing after the pilotless Red Dwarf Supplies are running low! , Fri 10:05, Sat 18:05

Red Dwarf 6 - "Legion" Stumbling across a super secret scientific base they encounter a mysterious creature whose plans are to keep the Red Dwarf crew as his companions for life. , Fri 10:35, Sat 18:35

Red Dwarf 6 - "Gunman Of The Apocalypse" When a computer virus infects StarBug's systems, it's Krylon the Android to the rescue in this very funny drama. , Fri 11:00, Sat 19:00

Red Dwarf 6 - "Emohawk Polymorph 2" A crash leaves the RD crew without a life support system so they marry Lister off to a space creature in a trade for a new one. , Fri 11:30, Sat 19:30

Red Dwarf 6 - "Rimmer World" Rimmer gets stranded on the far side of a time warp so he creates clones to keep him company, but something goes wrong. , Fri 12:00, Sat 20:00

Red Dwarf 6 - "Out Of Time" Rimmer stops being a coward and goes into action. , Fri 12:30, Sat 20:30

Sapphire and Steel - An adventure of three hardy souls. , Fri 04:25, Mon 04.25

Selling Hitler - Comedy Mini Series A comedy centered on a German Reporter who finds a person who says he has Hitler's diaries. The great fraud of our century as the price for these fakes goes through the roof. , Sat 04:00, Sun 20:00

Sherlock Holmes - "The Blue Carbunkel" With Peter Cushing as the dashing late 18th Century scientific detective. , Sun 05:15

Sherlock Homes - "The Last Vampire" Who will have the last bite? , Fri 20:00

Sherlock Holmes - "The Three Gables" With Jeremy Brett as Holmes , Sun 07:50

Ripping Yarns - Some really crazy English stories from the past., Thur 21:30, Sun 13:30

Spitting Image - British politics and the Royal Family are satirized through the use of overly large, garishly made up puppets, who just can't seem to get things right. , Fri 02:20, Mon 02:20

Star Cops - A great police adventure in space. , Thur 23:30, Sun 15:30

"Stuff" - A series of comic skits by Alexi Sales. Very funny weekly show in England. , Sun 01:00

The Avengers, "The Frighteners" A protection racket comes to the attention of The Avengers and they intervene to protect the innocent., Fri 13:00, Sat 21:00

The 10'er's - From the creators of Red Dwarf, a comic behind the scenes look at the world of acting agencies in England. , Fri 14:00, Sat 22:00

The Harry Enfield Television Program - Harry Enfield, that wonderful creator of gags and skits is back again with a wonderful new show. , Sun 02:50

The Lenny Henry Show - A comedy variety show, featuring a series of skits., Sun 04:45

The Making Of HitchHikers Guide To The Galaxy - A behind the scenes look at the production of the famous and not so serious comic cult sci fi classic series. Based on the radio play and books by Douglas Adams. , Fri 14:20, Sat 22:20

The Mary Whitehouse Experiences - Series The satirical show that former English censor Mary Whitehouse just LOVES to watch! Comedy skits cleanly lampooning censorship. , Sat 01:00, Sun 17:00

The New Statesman - The continuing legend of Alan Bustard, a former Parliamentary backbencher, now plying his trade in the European Communities Parliament. Serious drama of a ruthless individual. , Fri 15:20, Sat 23:20

The Stranger Series - "In Memory Alone" New series made by the BBC starring Colin Baker and Nicolaia Brian, which is based on Dr. Who. , Fri 08:00, Mon 08:00

The Stranger Series - "More Than A Messiah" Third in the series., Sat 12:20

The Stranger Series - "Summoned By Shadows" The Stranger has to deal with Aliens who are trapped on a planet enslaving the population. , Fri 21:45

Thirty Years Inside The Tardis - A behind the scenes look at the history of producing the internationally famous Doctor Who series. , Fri 09:15, Sat 17:15

"This Is David Lander" - A British investigative reporter studying the world. , Thur 22:30, Sun 14:30

The Young Ones - A story about 4 wacky English youths in their loves and triumphs! , Fri 06:55, Mon 06:55

Waiting For God - A comedy about the residents of a nursing home, who are trying to live their lives with dignity. , Sat 13:30

"THE SCIENCE CHANNEL"

LOCATION: CHARTER HOUSE HOTEL 5TH FLOOR

THURSDAY P.M. The Science Channel

12:07	Canada In Space - Destination Earth
13:05	The Space Movie
14:23	The Dream Is Alive
15:00	Welcome To Our Con
15:03	An Astronauts View Of Earth
15:50	Rocket Pilots - The X-15 Story
17:00	Thunderbirds, Epi 1, "Trapped In The Sky"
17:51	Russian Right Stuff, Pt 1, "The Invisible Spaceman"
18:48	The Planets, Pt 1, "The Children Of The Sun"
19:13	Spaceflight, Pt 1, "Thunder In The Skies"
19:58	One Moment In Time - Astronaut Roberta Bondar
20:57	Black Stars In Orbit - Afro-American Astronauts
21:54	The Stars, Pt 1, "Reach For The Stars"
22:19	Resp. Beh. Commercials- Tasha & Data, Guinon & Lal
22:23	Eclipse Of The Century - Over Hawaii
23:19	Alien Nation - The Series, "Alien Reproduction"

13:01	Spaceflight, Pt 3, "... One Giant Leap"
13:48	One Moment In Time - Astronaut Roberta Bondar's flight
14:47	Wings Over The World - "The Dassaut Dream"
15:33	Canada In Space - Destination Earth
16:31	Klutzy Kosmonauts
16:42	Making Sense Of Our Senses
17:00	Thunderbirds, Epi 7, "Vault Of Death"
17:52	Russian Right Stuff, Pt 2, "The Dark Side Of The Moon"
18:48	The Planets, Pt 3, "The Blue Planet"
19:14	Spaceflight, Pt 4, "The Territory Ahead"
19:59	Neptune's Cold Fury - Voyager 2's Nepture Fly-by
20:55	Orbital Mechanic's - Nicely Done Nasa Film
21:32	The Other Side Of The Moon - The Lives of 8 Moonwalkers
22:58	Resp. Beh. Comm. - Riker & Klingons, Worf in the gym
23:02	Soviet Science - "High Stakes Math"
23:12	Alien Nation - The Series, "The Male Birth"
23:59	Resp. Beh. Commercials - Picard & Data, Robin Williams

FRIDAY "The Science Channel"

00:05	Resp. Beh. Commercials- Picard & Data, Robin Williams
00:08	U.F.O. - Series Premier, "Identified"
01:00	Thunderbirds, Epi 2, "Pit Of Peril"
01:50	Resp. Beh. Comm. - Riker & Klingons, Worf & his lady
01:54	The Space Movie - 60's Nasa Footage To Music
03:12	Resp. Beh. Commercials - Lal & Riker, Monty Python
03:15	Deep Space Nine Premier "Emissary"
04:46	The Other Side Of The Moon - The Lives of 8 Moonwalkers
06:12	Mercury and Mars
07:12	Soviet Science - Medicine, and "Our Senses"
07:32	Stingray, Epi 1, "Stingray"
07:58	Red Dwarf 1, Premier "The End"
08:26	Red Dwarf 2, "Parallel Universe"
09:00	Thunderbirds, Epi 3, "City Of Fire"
09:54	Russian Right Stuff, Pt 2, "The Dark Side Of The Moon"
10:49	The Stars, Pt 2, "Message From The Stars"
11:17	From Apollo To The Stars
12:12	Wings Over The World - "Higher, Farther, Faster"
12:58	Journey To Mars - A Canadian Documentary
13:38	Eclipse Of The Century - Over Hawaii
14:34	Spytech - Our Eyes In The Sky
15:26	The Stars, Pt 3, "Secrets Of The Sun"
15:54	The Flight Of STS-52 - The Human Factor
17:00	Thunderbirds, Epi 4, "Sun Probe"
17:50	To Boldly Go - The Voyager's Explore The Gas Planets
18:46	The Planets, Pt 2, "Mercury and Venus"
19:12	Spaceflight, Pt 2, "The Wings Of Mercury"
19:57	Soviet Space: The Secret Designer
20:52	Wings Over The World - "Wings Over Italy"
21:38	Klutzy Kosmoauts
21:50	The Flight Of Apollo 11 - As It Happened
23:15	Resp. Beh. Commercials - Tasha & Data, Guinon & Lal
23:19	Alien Nation - The Series, "The Baby Transfer"

SUNDAY A.M. The Science Channel

00:02	U.F.O. The Series, Epi 3, "Survival"
00:48	The Transistor
00:52	Viking Satellites
01:00	Thunderbirds, Epi 8, "Operation Crash Dive"
01:51	Resp. Beh. Commercials - Tasha & Data, Guinon & Lal
01:54	Voyager 2's Neptune Fly-By - As It Happened Footage
03:49	Resp. Beh. Commercials - Lal & Riker, Monty Python
03:52	DUNE - Extended Narrated Director's Cut
06:52	The Dream Is Alive
07:29	Stingray, Epi 3, "Sea Of Oil"
07:55	Red Dwarf 5, "Holoship"
08:23	Red Dwarf 5, "Back To Reality", is this the End???
08:51	The Race To The Moon
09:00	Thunderbirds, Epi 9, "Move And You're Dead"
09:50	Russian Right Stuff, Pt 3, "The Mission"
10:46	The Stars, Pt 5, "Star Doom"
11:11	Soviet Space: The Secret Designer
12:04	The Flight Of STS-52 - The Human Factor
13:03	Wings Over The World - "The Dream Becomes A Disaster"
13:49	The Planets, Pt 4, "The Angry Red Planet"
14:16	The Voyager Odyssey
15:00	U.F.O. The Series, Epi 4, "Conflict"
15:47	Alien Nation, The Series, End of Series Cliff Hanger
16:34	Soviet Science - Medicine, and "Our Senses"
17:00	Thunderbirds, Epi 1, "Trapped In The Sky"
17:51	Russian Right Stuff, Pt 1, "The Invisible Spaceman"
18:48	The Planets, Pt 1, "The Children Of The Sun"
19:13	Spaceflight, Pt 1, "Thunder In The Skies"
19:58	One Moment In Time - Astronaut Roberta Bondar's Flight
20:57	Black Stars In Orbit - Afro-American Astronauts
21:54	The Stars, Pt 1, "Reach For The Stars"
22:19	Resp. Beh. Commercials - Tasha & Data, Guinon & Lal
22:23	Eclipse Of The Century - Over Hawaii
23:19	Alien Nation - The Series, "Alien Reproduction"

SATURDAY "The Science Channel"

00:05	U.F.O. The Series, Epi 2, "Exposed"
00:53	Resp. Beh. Commercials - Lal & Riker, Monty Python
01:00	Thunderbirds, Epi 5, "The Uninvited"
01:50	Giotto At Halley's Comet - As It Happened Off BBC
03:12	Resp. Beh. Commercials - Picard & Data, Robin Williams
03:15	Aliens - Extended Letterbox Director's Cut
05:50	Resp. Beh. Comm. - Riker & Klingons, Worf & his lady
05:53	The Space Movie - 60's Nasa Footage To Music
07:11	Soviet Science - High Stakes Math
07:32	Stingray, Epi 2, "Plant Of Doom"
07:58	Red Dwarf 4, "Dimension Jump"
08:27	Red Dwarf 4, "D.N.A."
09:00	Thunderbirds, Epi 6, "The Mighty Atom"
09:55	Russian Right Stuff, Pt 1, "The Invisible Spaceman"
10:47	The Stars, Pt 4, "A Star Is Born"
11:13	Chaos Theory
12:04	Black Stars In Orbit - Afro-American Astronauts

MONDAY A.M. The Science Channel

00:05	Resp. Beh. Commercials - Picard & Data, Robin Williams
00:08	U.F.O. - Series Premier, "Identified"
01:00	Thunderbirds, Epi 2, "Pit Of Peril"
01:50	Resp. Beh. Comm. - Riker & Klingons, Worf & his lady
01:54	The Space Movie - 60's Nasa Footage To Music
03:12	Resp. Beh. Commercials - Lal & Riker, Monty Python
03:15	Deep Space Nine Premier "Emissary"
04:46	The Other Side Of The Moon - The Lives of 8 Moonwalkers
06:12	Mercury and Mars
07:12	Soviet Science - Medicine, and "Our Senses"
07:32	Stingray, Epi 1, "Stingray"
07:58	Red Dwarf 1, Premier "The End"
08:26	Red Dwarf 2, "Parallel Universe"
09:00	Thunderbirds, Epi 3, "City Of Fire"
09:54	Russian Right Stuff, Pt 2, "The Dark Side Of the Moon"
10:49	The Stars, Pt 2, "Message From The Stars"
11:17	From Apollo To The Stars

"THE SCIENCE CHANNEL" ALPHABETICAL LISTING

An Astronauts View Of Earth . A look at our home planet through the eyes of Astronauts and Cosmonauts from space. Thur 15:03

Alien Nation - The Series, "A New Life..." An interesting look at the religious rituals, as a Newcomer (alien) family, prepares to conceive a child. Thur 23:19, Sun 23:19

Alien Nation - The Series, "Passing the Pod" Newcomer biology dictates that Newcomers share a pregnancy. Fri 23:19

Alien Nation - The Series, "Not Now George..." Refusing maternity leave, George goes into labour prematurely due to work stress during a shoot out. Sat 23:12

Alien Nation - The Series, "The Plague" The end of series cliff hanger, the human supremacists are plotting to wipe the Aliens off the face of the Earth. Sun 15:47

Aliens - Extended Letterbox Director's Cut 16 minutes added, not in the theatre or tape version. Sat 03:15

Black Stars In Orbit - Afro-Americans and what they endured trying to become Astronauts. Thur 20:57, Sat 12:04, Sun 20:57

Canada In Space - Destination Earth This documentary examines Canada's contribution to space exploration. Thur 12:07, Sat 15:33

Chaos Theory An excellent documentary that explores the mathematics of Chaos, which governs our weather and everything around us in nature. Sat 11:13

DUNE - Extended Narrated Director's Cut This narrated masterpiece tells the tale of Dune, with added footage not seen in theatres or on tape, making it more understandable. Sat 03:52

Eclipse Of The Century - "Over Hawaii" Nova takes a behind the scenes look at astronomers as they experience success or failure, to capture the first eclipse to pass over a major observatory. Thur 22:23, Sun 22:23

From Apollo To The Stars Where to we go from here? A look at plans for a Japanese space hotel and the plans for future space exploration. Fri 11:17, Mon 11:17

Giotto Looks At Halley's Comet - As It Happened Live Off BBC Follow the European Space Agency's Giotto as it makes mankind's first close encounter. Sat 01:50

Journey To Mars - A Canadian Documentary Will mankind get to Mars? This documentary examines the problems that have to be overcome. Fri 13:38

Klutzy Kosmonauts A short from Scientific American follows the Russian medical research into the effects of micro-gravity. Fri 21:38, Sat 16:31

Making Sense Of Our Senses A short made with the help of the Cdn Space Agency Astronauts to explain what happens to our balance in zero-g. Sat 15:42

Mercury and Mars A close up look at Mercury and Mars, and the destination of a manned mission in the next century. Fri 06:12, Mon 06:12

Neptune's Cold Fury - Voyager 2's Nepture Fly-by Patrick Stewart narrates this excellent documentary. Sat 19:59

One Moment In Time - TVO's documentary of the flight of Canada's first female space farer, Dr. Roberta Bondar. Thur 19:58, Sat 13:48, Sun 19:58

Orbital Mechanic's An excellent Nasa film that explains the math behind why and how we can orbit spacecraft. Sat 20:55

Red Dwarf 1, Premier "The End" The premier episode

of this wacked out space adventure explains how the ship's slob, Dave Lister, ends up alone 3 million years in the future. Fri 07:58, Mon 07:58

Red Dwarf 2, "Parallel Universe" First person on the Moon, Nelly Armstrong if you're in a Parallel Universe. Fri 08:26, Mon 08:26

Red Dwarf 4, "Dimension Jump" Who is this cool, suave, handsome Space Corp. test pilot? Arnold "Ace" Rimmer???.....Give me a break.... Sat 07:58

Red Dwarf 4, "D.N.A." The crew of Red Dwarf discovers a ship with a D.N.A. trans-mogrifier. Kryton gets his wish and is transformed into a human. Sat 08:27

Red Dwarf 5, "Holoship" Red Dwarf meets a ship crewed by holograms. Thur 07:55

Red Dwarf 5, "Back To Reality" Is this the end? Was Red Dwarf only a role playing game or are our intrepid adventurers in mortal danger..... Sun 08:23

Responsible Behavior Commercials
- Lal & Riker, Lal kisses Riker, without warning !!!
- Monty Python, How not to impress your male.
Fri 03:12, Sat 00:53, Sun 03:49, Mon 03:12

Responsible Behavior Commercials
- Picard & Data, "Data, I would like to have been consulted...."
- Picard asks Data why he made his android daughter
- Robin Williams, gives us some good advice.
Fri 00:05, Sat 03:12, Sat 23:59, Mon 00:05

Responsible Behavior Commercials
- Riker & Klingon ladies,
- Worf & his lady, Klingon dating rituals
Fri 01:50, Sat 05:50, Sat 23:58, Mon 01:50

Responsible Behavior Commercials
- Tasha & Data, don't use alcohol as an excuse,
- Guinan & Lal, "He's biling that female!" what do you say?
Fri 23:15, Sun 03:49, Sun 22:19

Rocket Pilots - The X-15 Story An examination of the the Space Shuttle precursor. Thur 15:50

Russian Right Stuff, Pt 1, "The Invisible Spaceman" A look at Sergei Korolov, the man behind the Russian Space Program. Thur 17:51, Sat 09:55, Sun 17:51

Russian Right Stuff, Pt 2, "The Dark Side Of the Moon" Russian attempt to win the race to land man on the Moon first. Fri 09:54, Sat 17:52, Mon 09:54

Russian Right Stuff, Pt 3, "The Mission" The Russian Cosmonaut training complex & a crew during their training & stay aboard the Mir Space Station. Sun 09:50

Soviet Science - "Medicine, and Our Senses" A short on Russian space medicine research. Fri 07:12, Sun 16:34, Mon 07:12

Soviet Science - "High Stakes Math" A short on the new Russian earthquake prediction techniques. Sat 07:11, Sat 23:02

Soviet Science - "Rescuing The Big Bird" Saving an endangered species Russian Style. Sat 07:11

Soviet Space: The Secret Designer A documentary about the life of the Sergie Korolov, the secret Chief Designer of Russian space program. Footage of the N-1 superbooster exploding. Fri 19:57, Sun 11:11

Spaceflight, Pt 1, "Thunder In The Skies" Martin Sheen narrates this presentation of American space research in the dawn of the space age. 19:13, Sun 19:13

Spaceflight, Pt 2, "The Wings Of Mercury" America's first Astronauts and the pioneering Mercury and Gemini programs. Fri 19:12

Spaceflight, Pt 3, "... One Giant Leap" The Apollo Program, the tragedy of the Apollo 201 pad fire, the Moon landing and America's first Space Station "SkyLab". Sat 13:01

Spaceflight, Pt 4, "The Territory Ahead" A speculative look at what the future in space holds for us. Sat 19:14

ST - Deep Space Nine Premier "Emissary" The movie length premier of this Star Trek: The Next Generation spin off. Fri 03:15, Mon 03:15

Spytech - Our Eyes In The Sky A critical look at our "eyes in the sky", their strengths and weaknesses. Fri 14:34

Stingray, Epi 1, "Stingray" A blast from our youthful past, the premier episode of Gerry Anderson's 1964 series about the adventures of Aquanaut Troy Tempest. Fri 07:32, Mon 07:32

Stingray, Epi 2, "Plant Of Doom" When Troy takes Marina home to the underwater city of Pacifica, she returns with a poisoned flower. Sat 07:32

Stingray, Epi 3, "Sea Of Oil" Commander Shore's daughter Atlanta is captured by an underwater race who believe that Troy is trying to destroy their seabed city. Sun 07:29

To Boldly Go - 12 years of outer Solar System exploration by Pioneer's 10 & 11 and Voyager's 1 & 2. Narrated by Patrick Stewart. Fri 17:50

The Dream Is Alive Walter Cronkite narrates this excellent film that takes us into orbit on the Space Shuttle. Thur 14:23, Sun 06:52

The Flight Of Apollo 11 Historic footage mixed with documentary commentary to show the first manned Moon landing as it happened. Fri 21:50

The Flight Of STS-52 - The Human Factor follows Astronaut Steve McLean, the third Canadian in space, as he and his crew mates prepare for the flight of STS-52. Fri 15:54, Sun 12:04

The Other Side Of The Moon Story of eight of the twelve Apollo Astronauts who journeyed to the moon's surface. Fri 04:46, Sat 21:32, Mon 04:16

The Planets, Pt 1, "The Children Of The Sun" British astronomer Heather Couper's seven part guided tour of our Solar System. Thur 18:48, SUN 18:48

The Planets, Pt 2, "Mercury and Venus" A close up look at Mercury and Venus. Fri 18:46

The Planets, Pt 3, "The Blue Planet" We call it "The Earth". But how was it created? Sat 18:48

The Planets, Pt 4, "The Angry Red Planet" Was there actually water flowing on Mars in the past? A guided tour of the fourth planet from our Sun. Sun 13:49

The Race To The Moon A short film about the Moon landings. Sun 08:51

The Space Movie 60's Nasa footage put to music of Mike Oldfield's "Tubular Bells". Thur 13:05, Fri 01:54, Sat 05:53, Mon 01:54

The Stars, Pt 1, "Reach For The Stars" A journey beyond our Solar System to explore The Stars. Thur 21:54, Sun 21:54

The Stars, Pt 2, "Message From The Stars" How do we examine a star that is billions upon billions of kilometers away? Fri 10:49

The Stars, Pt 3, "Secrets Of The Sun" What makes a star burn so brightly? Fri 15:46

The Stars, Pt 4, "A Star Is Born" Where do stars and solar systems come from? Sat 10:47

The Stars, Pt 5, "Star Doom" When a star goes out, what happens to what is left behind? Sun 10:46

The Transistor A short, on the development of the transistor. Sat 00:48

The Voyager Odyssey Journey through the outer solar system with Voyager. Sun 14:16

Thunderbirds, Epi 1, "Trapped In The Sky" The premier episode of Gerry Anderson's Thunderbirds They attempt to save the passengers and crew of the atomic airliner FireFlash. Thur 17:00, Sun 17:00

Thunderbirds, Epi 2, "Pit Of Peril" "The Sidewinder" disappears beneath the ground trapping the crew. Fri 01:00, Mon 01:00

Thunderbirds, Epi 3, "City Of Fire" A shopping mart is evacuated due to a terrifying fire, a family is trapped. Fri 09:00, Mon 09:00

Thunderbirds, Epi 4, "Sun Probe" The research space ship "Sun Probe" goes out of control. Fri 17:00

Thunderbirds, Epi 5, "The Uninvited" Thunderbird 1 is forced down in North Africa by three mysterious fighters. Sat 01:00

Thunderbirds, Epi 6, "The Mighty Atom" The Hood audaciously steals "The Mighty Atom", a robot rat that can be programmed to take photos. Sat 09:00

Thunderbirds, Epi 7, "Vault Of Death" A Bank of England employee is trapped in a time-locked vault with the air being pumped out. Sat 17:00

Thunderbirds, Epi 8, "Operation Crash Dive" Two Fireflash atomic airliners crash into the Atlantic under mysterious circumstances. Sun 01:00

Thunderbirds, Epi 9, "Move And You're Dead" A jealous racing car rival strands Alan Tracy & Grandma on a bridge with bomb. Sun 09:00

Thunderbirds, Epi 10, "Martian Invasion" Using hypnosis The Hood gets his half-brother (the Tracy family's butler) Kyrano to immobilize the camera detector in Thunderbird 1. Sun 17:00

U.F.O. - Series Premier, "Identified" The Premier Episode of Gerry Anderson's Sci-Fi space spectacular, starring American actor Ed Bishop, as Commander Straker of SHADO. Fri 00:08, Sun 00:08

U.F.O. The Series, Epi 2, "Exposed" Civilian test pilot, Paul Foster, photographs a UFO during its interception and then crashes. Sat 00:05

U.F.O. The Series, Epi 3, "Survival" A window in the SHADO Moonbase blows out killing an interceptor pilot, but a bullet of Alien origin is the cause. Sun 00:02

U.F.O. The Series, Epi 4, "Conflict" Ed Straker is convinced that space debris -discarded rocket boosters and other junk - is both a danger and a cover for alien activity. Sun 15:00

Viking Satellites A short on the 1976 US Viking Mars landers. Sun 00:52

Voyager 2's Neptune Fly-By Actual As-It-Happened recorded live from JPL with progress reports, interviews with the project scientists and the fantastic images of Neptune and it's Moon Triton. Sun 01:54

Welcome To Our Con - Science Channel Greet's Our Members A mix of sci/fi video & graphics welcoming con goers. Thur 15:00

Wings Over The World - "Higher, Farther, Faster" In this episode on aviation history, we look back at the development of high speed aircraft. Fri 12:12

Wings Over The World - "The Dassaut Dream" The history of aviation in France, and the work of Marcel Dassaut, the French aviation visionary. Sat 14:47

Wings Over The World - "Wings Over Italy" Early in this century Italy made some of the fastest aircraft in the world. Fri 20:52

Wings Over The World - "The Dream Becomes A Disaster" In the late forties, early fifties the British led the world into the era of passenger jet transport with "The Comet". Sat 13:03

JAPANESE VIDEO PROGRAM SCHEDULE

LOCATION: CHARTER HOUSE HOTEL LOWER LEVEL

THURSDAY Japanese Video

Action	2:00 PM	Burn Up
Comedy	2:45 PM	Shonan Bokuzozoku
Fantasy	3:40 PM	Girl from Phantasia
CyberPunk	4:20 PM	Bubblegum Crisis 1
CyberPunk	5:10 PM	Bubblegum Crisis 2
CyberPunk	5:40 PM	Bubblegum Crisis 3
CyberPunk	6:10 PM	Bubblegum Crisis 4
CyberPunk	6:50 PM	Bubblegum Crisis 5
CyberPunk	7:35 PM	Bubblegum Crisis 6
CyberPunk	8:20 PM	Bubblegum Crisis 7
CyberPunk	9:05 PM	Bubblegum Crisis 8
SF	9:55 PM	Genesis Survivor Gaiarth Stage 1
SF	10:50PM	Genesis Survivor Gaiarth Stage 2
SF	11:40PM	Genesis Survivor Gaiarth Stage 3
SF/Action	12:25AM	Madox-01 Metalskin Panic

FRIDAY Japanese Video

SF	10:00 AM	Arcadia, My Youth Of
SF/Comedy	12:10 PM	Urusei Yatsura 1 OnlyYou
SF/Comedy	1:55 PM	Urusei Yatsura 2 Beautiful Dreamer
SF/War	3:35 PM	Venus Wars
Satire	5:25 PM	Otaku No Video
Horror	7:05 PM	Vampire Princess Miyu
CyberPunk	8:55 PM	Battle Angel
SF/Fantasy	9:55 PM	Tenchi Muyou 1
SF/Fantasy	10:25 PM	Tenchi Muyou 2
SF/Fantasy	10:55 PM	Tenchi Muyou 3
SF/Fantasy	11:25 PM	Tenchi Muyou 4
SF/Fantasy	11:55 PM	Tenchi Muyou 5
SF/Fantasy	12:25 AM	Tenchi Muyou 6
SF/Comedy	1:00 AM	Maris the Chojo

SATURDAY Japanese Video

SF/Action	10:00 AM	Black Magic M-66
SF	10:50 AM	Gunbuster volume 1
SF	11:50 AM	Gunbuster volume 2
SF	12:50 PM	Gunbuster volume 3
SF/Fantasy	1:50 PM	Crystal Triangle
SF	3:20 PM	Fire Tripper

SF	4:10 PM	Gall Force: Eternal Story
SF	5:40 PM	Harmageddon
Horror	7:55 PM	Laughing Target
SF	8:50 PM	Odin
SF/Comedy	11:10PM	Tank Police Dominion 1
SF/Comedy	11:50PM	Tank Police Dominion 2
SF/Comedy	12:30 AM	Tank Police Dominion 3
SF/Comedy	1:10 AM	Tank Police Dominion 4

SUNDAY Japanese Video

SF/Action	10:00AM	Appleseed
SF/Comedy	11:10AM	Project A-Ko
SF	12:35PM	They Were 11
SF/Comedy	2:10 PM	Urusei Yatsura 3 Remember My Love
SF/Comedy	3:45 PM	Urusei Yatsura 4 Lum The Forever
SF	5:20 PM	Gundam 0083 Stardust Memories 1
SF	5:50 PM	Gundam 0083 Stardust Memories 2
SF	6:20 PM	Gundam 0083 Stardust Memories 3
SF	6:50 PM	Gundam 0083 Stardust Memories 4
SF	7:20 PM	Gundam 0083 Stardust Memories 5
SF	7:50 PM	Gundam 0083 Stardust Memories 6
SF	8:20 PM	Gundam 0083 Stardust Memories 7
SF	8:50 PM	Gundam 0083 Stardust Memories 8
SF	9:20 PM	Gundam 0083 Stardust Memories 9
SF	9:50 PM	Gundam 0083 Stardust Memories 10
SF	10:20 PM	Gundam 0083 Stardust Memories 11
SF	10:50 PM	Gundam 0083 Stardust Memories 12
SF	11:20 PM	Gundam 0083 Stardust Memories 13
Occult	11:50 PM	Karula Mau
Close	1:10 AM	

MONDAY Japanese Video

SF	10:00 AM	Time Stranger
SF/Comedy	11:30 AM	Video Girl Ai 1
SF/Comedy	12:00 PM	Video Girl Ai 2
SF/Comedy	12:30 PM	Video Girl Ai 3
SF/Comedy	1:00 PM	Video Girl Ai 4
SF/Comedy	1:30 PM	Video Girl Ai 5
SF/Comedy	2:00 PM	Video Girl Ai 6
Close	2:30 PM	

GAMES PROGRAMMING

PLACE: Place Louis Riel Hotel [Winnipeg, Manitoba]

GAMES REGISTRATION:

Florida Room Foyer Area
 1st Floor, (near Hotel Front Desk)
 Open: 8am - 12am (Thursday - Saturday)
 8am - 10pm (Sunday)
 10am - 3pm (Monday)

[Those interested in gaming, in entering SciFi/Fantasy Miniatures painting contest, or participating in the Game Auction should register here.]

GAMING OPS: Penthouse Office Area (24th Floor)
 DIRECTOR: Brian Myhre

OPEN GAMING: 22 hours/day (gamers will be asked to leave this space daily from 6am - 8am for clean-up)

Open: 8am, Sept. 1st
 Closed: 3pm, Sept 5th
 Location: Atlantic Room (Florida Room Area, 1st Floor.)

We have over 400 square feet of open gaming space, that will (barring supervision) remain open 24 hours a day, for most of the convention. Anyone with either a Full WorldCon membership or a Gamers Poverty Bracelet will be allowed access to this space. This space may be used to play most table top playable games (RPG's, Boardgames, Wargames, etc., dice and some games available for use in this space.)

SCHEDULED GAMES: (Demo's and Tournaments)

Open: 10am _ 2am Thursday - Sunday
 10am _ 3pm Monday

Location: Pacific and Baltic Rooms
 (Florida Room Area, 1st Floor)
 Manitoba Room (1st Floor near ConSuite)
 Boardwalk Room Area (1st Floor near ConSuite;
 including six small rooms)
 Penthouse Suite (24th Floor; take elevator to 23rd floor and stairs to 24th)

DEMONSTRATION GAMES:

Thursday, Sept 1st : *Advanced Squad Leader Demo, Battle System, BattleTech/BattleSpace, Berzerker Demo, Call of Cthulhu, CarWars, CyberPunk, FullThrust, Talisman 3rd Edition, Tales of the Floating Vagabond, Top Secret, Vampire*

Friday, Sept 2nd : *BattleTech, CarWars, Civilization Boardgame, CyberPunk, Middle Earth RPG, Over the Edge, Paranoia, Space 1889/Soldier's Companion, Teenage Mutant Ninja Turtles, WarHammer Fantasy, Warhammer 40K, Warhammer 40K Dark Millennium.*

Saturday, Sept 3rd: *Axies & Allies, Battle Tech, Blood Bowl, Circus Imperium, Napoleon's Battles, Nexus RPG (Chaosium), Stormbringer.*

Sunday, Sept 4th : *Axies & Allies, Renegade Legion/Centurion, Space Hulk/Tyrannid Attack, Toon, Traveller New Era/ Brilliant Lances.*

TOURNAMENT GAMES:

Thursday, Sept 1st : *CyberPunk 2020, Full Thrust, MAGIC the Gathering 'Intermediate', Shadowrun, Talisman 3rd Edition.*

Friday, Sept 2nd : *AD&D (4 players per team) Rnd1, BattleTech 'Lance' and 'Solaris 7' tourneys, Call of Cthulhu, Champions, CyberPunk 2020, MAGIC the Gathering 'Intermediate' and 'Advanced' tourneys, Paranoia, Shadowrun, Star Fleet Battles Captain's, Tunnels & Trolls/Mercenaries, Spies & Private Eyes Combo.*

Saturday, Sept 3rd : *AD&D (4 players per team) Rnd2, BattleTech 'Solaris 7', BloodBowl, Champions, Civilization, CyberPunk 2020, S.F.B. Captains, MAGIC the Gathering, 'Advanced' Finals, Mercenaries, Spies and Private Eyes Tourney (T&T combo), Rifts, S.F.B. Cadets, Warhammer 40K (Miniatures needed).*

Sunday, Sept 4th : *BattleTech 'Lance', Car Wars, Rifts, Champions, S.F.B. Captains and Cadets, Tunnels & Trolls / M.S.P.E. Tournament Combo.*

GAME AUCTION:

Sunday, Sept 4th: 10am - 2pm (Buyers and Sellers should register at Games Registration Desk by Saturday, Sept 3rd at 10pm. WorldCon commission 10%)

MINIATURE PAINTING CONTEST:

Classes : Master - Novice - Judges Best of Show - People's Choice.

Categories : Single Figs - SciFi, Fantasy, Battle Squad (SciFi or Fantasy), mounted (horse, bike, etc.), diorama (2+ figs on any base; should related theme or story), vehicle (scale: from Epic to WHFB/40K or under),

Young Bloods Competition: (single figs: For Ages 14 & under).
 Judge: Tim Huckelbery - Games Workshop
 Final Registration Date: Sept 3rd - 8pm

FOR MORE INFORMATION PLEASE REFER TO THE GAMES PROGRAM GUIDE
 (Available at Games Programming Registration Counter)

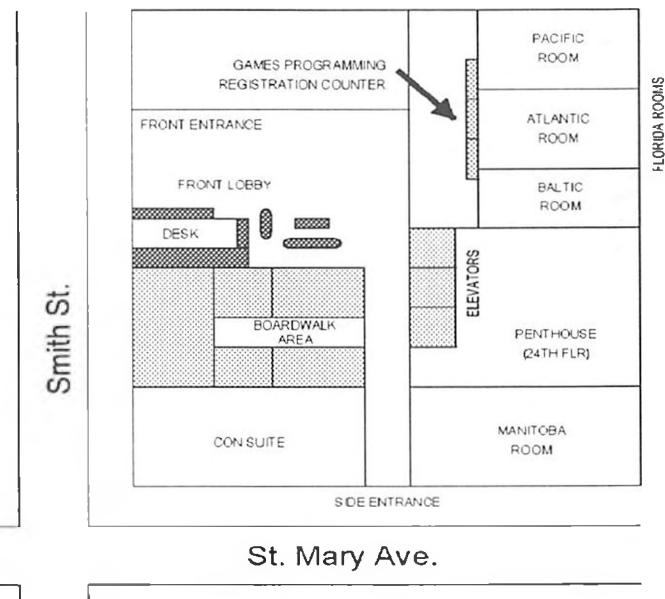

FILK PROGRAM SCHEDULE

----- Thursday, Sept. 1 -----

02:00-02:30 MR16 Concert, Decadent Dave Clement
 02:30-03:00 MR16 Concert Stephanie Bedwell-Grime
 03:00-03:30 MR16 Concert, John Speelman
 03:30-04:00 MR16 Concert, Kate Soley
04:00-04:30 MR16 Concert, Graham Leathers
 04:30-05:00 MR16 Concert, Judith Hayman
 05:00-06:00 MR16 Panel, Writing parody / humour
 Diane Sankey, Roberta Rogow, Graham
 Leathers, Brett Glass Panelists discuss
 how they go about putting a humorous
 bent in their songs.
 08:30-10:30 MR16 Open drum jam
 08:30—9:30 MR14 Jam, Songs of Science Fiction
 sign up in the Filk Lounge
 08:30—> MR15 Open filking
 09:30—> MR14 Open filking
 10:30—> MR16 Open filking

----- Friday, Sept. 2 -----

11:00-12:00 MR16 Workshop, Performance skills
 w/Kathy Mar sign-up in Filk Lounge
 12:00-12:30 MR16 Concert, Andrea Yeomans
 12:30-01:00 MR16 Concert, Roberta Rogow
 01:00-01:30 MR16 Concert, Jordin Kare
 01:30-02:00 MR16 Concert, Diane Sankey & Sylvia Fisher
 02:00-03:00 CAMP-S Panel, Pegasus Awards, listen & vote
 Glenn Simser
 02:00-02:30 MR16 Concert, Nate Bucklin
 02:30-03:00 MR16 Concert, Mary Ellen Wessels
 03:00-04:00 CAMP-S Workshop, Song Writing - introductory
 Lynn Gold, Graham Leathers, Allison
 Durno, Judith Hayman
 Song writing 101, for those who think they
 can't write a song.
 03:00-03:30 MR16 Concert, Kathy Mar
 03:30-04:00 MR16 Concert, Bill Roper
 04:00-05:00 CAMP-S Workshop, Voice
 Mary Ellen Wessels, Dave Clement
 Tips on breathing right and other fine points
 in the use of voice,
 04:00-04:30 MR16 Concert, Pete Grubbs
 04:30-05:00 MR16 Concert, Roger Burton-West
 05:00-06:00 CAMP-S Workshop, Filk instrumentation
 - guitar Joey Shoji, Pete Grubbs, Nate
Bucklin Picking and strumming tips from
 some of the best.
 05:00-06:00 MR16 Concert, Urban Tapestry
 08:30-09:30 MR14 Panel, Filk in the U.K.
 Kate Soley, Roger Burton-West, Kathy
 Mar What happening in the overseas
 filk community.
 08:30-10:30 MR16 Jam, Songs of Star Trek
 Judith Hayman, Urban Tapestry, Glenn
 Simser, Kathleen Sloan, Roberta Rogow
 08:30-10:30 MR15 Workshop, Filk instrumentation, assorted
 instruments Banjo: Graham Leathers, ✓
 cittern & dulcimer: Tom Jeffers, ~
 flute/recorder/pennywhistle: Kylea Fulton, ✓
 bass: Brett Glass,
 omnichord: Roger Burton-West,

There is more to filk music than just guitar and voice.

09:30-10:30 MR14 Jam, Filk International
 Kate Soley, Graham Leathers, Pete Grubbs
 10:30—> MR14 Open filking
 10:30—> MR16 Open filking
 10:30—> MR15 Open filking

----- Saturday, Sept. 3 -----

11:00-12:00 MR16 Panel, Folk Music in SF/F
 Joey Shoji, Mary Ellen Wessels, Elizabeth
 Ann Scarborough Which authors draw
 heavily on folk music in their writing? How
 is folk music relevant to SF/F?
 12:00-04:00 MR16 Filk Sampler
 15 minute filk teasers
 02:00-03:00 CAMP-S Workshop, Harmony singing
 Lynn Gold, Joey Shoji, Jodi Krangle, Cheryl
 Miki Just how do you get those awesome
 sounds?
 03:00-04:00 CAMP-S Panel, Taking filk beyond the con
 Kathy Mar, Graham Leathers, Joey Shoji,
 Dave Clement
 So what do you do with all of this great
 music when there are no cons going on?
 Can/does filk survive in the mainstream (or
 a side stream)?
 04:00-05:00 CAMP-S Workshop, Song Writing - advanced
 Kathy Mar, Pete Grubbs, Nate Bucklin
 For those who are already writing songs,
 some tips from some of the finest song
 writers around.
 04:00-04:30 MR16 Concert, Lynn Gold
 04:30-05:00 MR16 Concert, Joey Shoji
 05:00-06:00 CAMP-S Panel, Filk fandom
 Roberta Rogow, Stephanie Bedwell-Grime,
 Judith Hayman, David Hayman, Kathleen
 Sloan, Glenn Simser
 So what is this filk fandom I keep hearing
 about?
05:00-06:00 MR16 Concert, Dandelion Wine
 08:30-10:30 MR14 Jam, Parody / humour
 Roberta Rogow, Kathy Mar, Pete Grubbs,
 Graham Leathers, Brett Glass
 08:30-10:30 MR16 Workshop, Performance Anxiety
 w/ Mary Ellen Wessels
 sign up in Filk Lounge
 08:30-09:30 MR15 One shots, filk performances
 sign-up in Filk Lounge
 09:30-10:30 MR15 Workshop, Unfinished Songs
 sign up in Filk Lounge
 10:30—> MR14 Open filking
 10:30—> MR16 Open filking
 10:30—> MR15 Open filking

----- Sunday, Sept. 4 -----

11:00-12:00 CAMP-S Pegasus Awards, listen & vote
 Glenn Simser
 11:00-12:00 MR16 Workshop, Performance skills with Pete
 Grubbs sign-up in Filk Lounge
 12:00-02:00 MR16 Songs from the worlds of Ann McCaffrey
 Andrea Yeomans, Judith Hayman, Sylvia
 Fisher, Diane Sankey, Kathy Mar, Kate
 Soley, Joey Shoji

----- Sunday Continued -----

02:00-03:00 MR16 Instant Band showcase #1
sign-up in Filk Lounge

03:00-03:30 MR16 Interfilk Auction part 1

03:30-04:30 MR16 Instant Band showcase #2
sign-up in Filk Lounge

04:00-05:00 MR?? Panel, Filk, Past & Future
Roberta Rogow, Kathy Mar, Bill Roper,
David Hayman, Jordin Kare
A look back at where filk has come from, a
look forward at the exciting directions it is
headed.

04:30-05:00 MR16 Interfilk Auction part 2

05:00-06:00 MR?? Etiquettes of Filking
Bill Roper, Mary Ellen Wessels, Athena
Jarvis Can you bring a tuba to a filk circle?
What is the difference between chaos and
bardic? These and other questions
answered.

05:00-06:00 MR16 Instant Band showcase #3
sign-up in Filk Lounge

08:30-09:30 MR14 Panel, Recording, independents &
companies. Bill Roper, Graham Leathers,
Jordin Kare, Jodi Krangle, Gretchen Roper,
Tom Jeffers
What are the ins and outs of recording?

08:30-09:30 MR16 Jam, Always Steal from the Best
Mary Ellen Wessels, Kathleen Sloan,
Decadent Dave Clement
sign-up in Filk Lounge

08:30-09:30 MR15 One shots, filk performances
sign-up in Filk Lounge

09:30-10:30 MR14 Panel, Group vs. solo performing
Stephanie Bedwell-Grime, Pete Grubbs,
John Speelman, Graham Leathers, Allison
Durno Do you go for safety in numbers
or do you go it alone? What are the
advantages and drawbacks of each choice?

09:30-10:30 MR16 Jam, Songs from the books we love
Joey Shoji, Bill Roper, Judith Hayman,
Mary Ellen Wessels

09:30-10:30 MR15 Jam, Songs of Fantasy
sign-up in Filk Lounge

10:30—> MR14 Open filking

10:30—> MR16 Open filking

10:30—> MR15 Open filking

----- Monday, Sept. 5 -----

11:00-12:00 MR16 Song Writing Competition judging
sign-up in Filk Lounge

12:00-01:00 MR1 Panel, What is Filk?
Glenn Simser, Judith Hayman, David
Hayman, Howard Scrimjour, Mary Ellen
Wessels, Andrea Yeomans
The definitive panel on Filk.

01:00-02:00 MR16 Panel, How to survive running a filk con
Kathy Mar, Judith Hayman, Lynn Gold, Bill
Roper Survival tips from those who have
been through it — and lived.

02:00-03:00 MR16 Conadian filking, beefs & bouquets
Dave Clement
A chance for you to gush effusively about
how great everything was, or was not.

GENERAL PROGRAM INFO

HOW TO READ THE PROGRAM LISTING

Each entry in the listing can be
composed of 4 sections

TITLE
DESCRIPTION
PARTICIPANTS
DATE/TIME/TOPIC/LOCATION

TITLES are in a bold type face. If
there are multiple entries under
one title only the first title will
be shown.

DESCRIPTION The descriptions
are a guide to the content or focus of
the program item.

PARTICIPANTS ETC. will be
listed for each event in the
program listing.

TOPIC Numbers... XANNN

X 1 - 9/1/94 2 - 9/2/94
3 - 9/3/94 4 - 9/4/94
5 - 9/5/94

A * Start time add 30 min.

A - 9:00 AM / 9:00
B - 10:00 AM / 10:00
C - 11:00 AM / 11:00
D - 12:00 PM / 12:00
E - 1:00 PM / 13:00
F - 2:00 PM / 14:00*
G - 3:00 PM / 15:00*
H - 4:00 PM / 16:00*
I - 5:00 PM / 17:00*
J - 6:00 PM / 18:00*
K - 7:00 PM / 19:00*
L - 8:00 PM / 20:00*
M - 9:00 PM / 21:00*
N - 10:00 PM / 22:00*
O - 11:00 PM / 23:00*
P - 12:00 PM / 24:00*

NNN 3 Digit Topic Num

PROGRAM ROOM LOCATIONS

HALL "B" - 3rd floor of the Wpg Convention
Center

MR 2EFG - 2nd floor of the Wpg Convention
Center

MR 1 thru 15 - 1st floor of the Wpg Convention Center

WEST - Westminster Room West 2nd floor
Holiday Inn

Concourse - 3rd floor of the Wpg Convention
Center

Con Cont Loop - WCC outside main entrancenear
registration 1st floor

CAMP-S - Campaign room "South" 2nd floor
Holiday Inn



PROGRAM LISTING

DAY 1 - THURSDAY SEPT 1/94

- 14:00 HALL "B" **Opening Ceremonies** Doors open at 1 pm ConAdian will host a show with local and fanish activities, including the traditional welcoming speeches and introductions. Barry B. Longyear serves as this year's Master of Ceremonies so drop by and welcome in the 52nd World Science Fiction Convention.
- 14:00 MR15 1F516 **How to Enjoy Your First WorldCon** So you took the Big Step and came. Here's some help in making yours a great convention. Kathei Logue Bill Farina Jan Howard Finder David W Clark Leah Zeldes Smith Richard Smith Robin Wulff
- 15:00 MR 1 1G646 **1973 Worldcon Remembered** Torcon II...Toronto 1973... The sites, the smells, the convention. Will time ever tell us what really happened? Or will we just make it up. Ken Smookler
- 15:00 MR 2 1G134 **Genre Crossing** When is an SF story not an SF story? Joe Haldeman Dr. Janice Bogstad Adrienne Foster Peter J Heck Ron Sarti
- 15:00 MR15 1G002 **Steps in Getting From Manuscript to Finished Book** Does the "finished book" exist? Should "finished book" become an anachronism? What comes after the finished book? Kathryn Cramer Kristine Kathryn Rusch Richard Knaak Dean Wesley Smith Dr. William Sarjeant Shelly Shapiro Moshe Feder
- 16:00 MR 1 1H640 **1997 Worldcon Bid Presentations** Before you vote, take one good look at those who want to host the 1997 worldcon. Mike Glycer
- 16:00 MR 2 1H615 **The Technology of Magic** Are there any universal rules? How can you keep the magic consistent? How much can you borrow? Greg Costikyan Maia Cowan Jack L Chalker Julia Martin Edmund R. Meskys Harry C Stubbs
- 16:00 MR 7 1H006 **Living With a Writer** Is living with a writer like living alone? Are all writers insane? The ups and downs of living with a writer. Christine Valada Jeremy Bloom Richard Chwedyk Carolyn Clink Laura Frankos
- 16:00 MR 9 1H051 **German SF** German SF: A short market report. Who publishes SF after four out of six publishing houses (pocket books) closed their SF section in 1986? What goes on SF-wise besides books, like movies (The High Crusade) and the Fantasy Filmfest? Myra Cakan Waldemar Kummig
- 16:00 MR13 1H096 **SF Origins** Are we running the Chicken and the Egg theory again? How did SF begin? Bradford Lyau David Kyle Arthur Kyle Jean-Louis Trudel Ariane Von Orlow
- 17:00 MR 1 1I633 **Is It Fantasy If You Rip It Off From History** How to use history to help shape a good fantasy story. Anthony Bryant Roger Burton-West Sasha Miller Kate Soley
- 17:00 MR 2 1I614 **Never Make It Easy On Your Hero/Heroine** After all, what kind of hero is he if he lives in Care Bear Land? Jean Lorrach Shariann Lewitt Geoff Ryman K. D. Wentworth
- 17:00 MR 4 1I017 **Should SF Have Rivets?** Everything in life and beyond has a structure, but must we know the "science" behind every facet of existence? Ken Meltzner Jonathan V. Post Maia Cowan Bart Kemper Allen Steele
- 17:00 MR13 1I236 **Virtual Reality** How real can it be if you can't touch it? A discussion of VR and how it can work for you. Dr. Arlan Andrews Ashley D Grayson Jack Nimersheim Perry Mark Stratyckuk Amy Thomson
- 17:00 MR14 1I361 **Hands-On Parliamentary Procedure Workshop** An introduction to parliamentary procedure and Robert's Rules of Order, the rules which govern the WSFS Business Meeting. We'll cover basic procedure, with special emphasis on procedures you'll see at most WSFS Meetings. If you've ever wanted to participate in the WSFS Business Meeting, but felt intimidated by the procedural rules, you'll want to attend this meeting. Kevin Standlee
- 19:00 Norwood Hotel 1L741 **Spider's Place** This year's non filk musical extravaganza - 1/2 hour sets of mostly acoustic music. Entertainers include Joe Haldeman, Peter Heck, Tam Gordye... Spider Robinson Jeanne Robinson
- 19:00 WEST 1K641 **Mark Protection Committee Meeting** The WSFS Mark Protection Committee administers the service marks on "Worldcon", "Hugo Awards", and the other WSFS marks. This committee meeting is open to all members of ConAdian, seating permitting. The committee will consider its report to the WSFS Business Meeting Kevin Standlee
- 20:00 MR 7 1L009 **Tarot Workshop** Basic workshop for beginners. Covers choosing, initiating, and maintaining a deck. Also what to do when a deck goes "bad". Sunnie Andreu

DAY 1 - THURSDAY SEPT 1/94 - continued

- 20:00 MR 9 1L675 **Enterprise 2067** Bent Science Demonstration: We came in peace for all mankind-future space conquistadors will have to make ships which can fight in space. The lecture and demo is on how to design and build a real interplanetary cruiser. David Stephenson
- 20:00 Norwood Hotel **Spiders Place** Join Spider Robinson as he hosts an evening of nonfilk music. Join other fans and pro's as they try to impress one another with their musical talent. Participants will play half-hour sets before jamming together.
- 21:00 MR 1 1M619 **Sources of Fear in Horror** It's fun to be scared from time to time. Here's how the writer can create mood, shock, and suspense. William R. Lund Beverley Richardson
- 21:00 MR12 1M348 **Star Trek Parody**, Ahead warp speed with the Standart Orbit Players and their Star Trek presentation. It's funny; it's irreverent; it will make Spock blush to the tips of his pointed ears.
- 21:00 MR13 1M015 **Alternate Histories** If you could change one event in the past, how would today's history change? What are the rules of alternate histories? Ginjer Buchanan Glenn Grant Philip Kaveny Evelyn Leeper Allen Steele Harry C Stubbs
- 22:00 MR13 1M782 **So You've Been Taken Aboard a UFO! An Etiquette Guide for Abductees**. Remember: When greeting an unknown species, shake only the proffered tentacle. Chris Rutkowski
- 23:00 MR 1 1O075 **Urban/Dark Fantasy** We see it in the paper and on the nightly news. Are we as a culture fascinated with Death? Stephanie Bedwell-Grime Stephen Dedman Dawn Dunn Terry O'Brien Dale Sproule Richard Knaak

DAY 2 - FRIDAY SEPT 2/94

- 09:00 Fort Garry Hotel 2A767 **N3F Breakfast** A dutch treat breakfast. Diane Miller
- 09:00 MR 8 2A080 **Aerobics** Exercise for the fanish masses. Come on, it's good for you! John Douglass
- 10:00 CAMP-S 2B000 **ASFA Meeting** Annual meeting of ASFA, the SF/F artist organization advocating for Artists and their work.
- 10:00 Con Ctr Loop 2B761 **Blood Drive** Since the dawn of time Worldcons have had Blood Drives, Conadian will be no different. The Red Cross will provide a bus on Friday, September 2nd. It will run at the hours of 10am and 11am. Pick up is in the loop in front of the Convention Centre. Photo ID is required to donate, and it is asked that donors eat before hand.
- 10:00 ConCourse 2B800 **Autograph Sessions** Jean Lorrach Elizabeth Moon Jody Lynn Nye
- 10:00 MR 1 2B007 **The Business of Writing** Can you survive writing SF alone? Should you concentrate on the "art" and leave the business to an agent? Are you in it just for the money? Dave Wolverton Ian Ballantine Betty Ballantine Rebecca Moesta Anderson M Shayne Bell L Warren Douglas David Feintuch
- 10:00 MR 5 2B830 **KaffeeKlatsch** Limited ADVANCE registration - inquire at Con Info Desk Alan Barclay Donald Kingsbury George (Lan) Laskowski Larry Niven Elisabeth Vonarburg
- 10:00 MR 7 2B519 **Solar Power Satellites and Energy Politics** Let's take a look at solar power via the slide projector. John Strickland Jr.
- 10:00 MR 9 2B221 **Origami Workshop** Mark will teach folding figures the attendees choose from a selection of simple, intermediate, and difficult paperfolds. Subjects include dinosaurs, aliens, spacecraft, etc. Attendees are encouraged to show and teach figures of their own and to experiment. Most of the figures that Mark teaches are his own inventions. Featured: X-wing fighter Mark Leeper
- 10:00 MR10 2B670 **Reading by Heather Spears** Heather Spears reads her own work. Heather Spears
- 10:00 MR12 2B520 **Debunking Pseudoscience** Most SF writers knowingly use pseudoscience. Where do we draw the line? Jack Nimersheim George Flentke Hayford Peirce Howard Scrimgeour Susan M Smith Keith G. Kato
- 10:00 MR14 2B748 **Society for the Preservation of SF Fandom History** Dedicated to the physical preservation of endangered fanish materials. Networking, cataloguing resources and idea sharing encouraged! Peggy Rae Pavlat
- 10:00 MR15 2B638 **Starting a New Convention** How and why some cons were started, how they have been maintained, and a few of the problems they had to fix along the way. Cindy Huckle Franklin Hummel Val Ontell Robert Runte Sue Weinlein
- 11:00 ConCourse 2C801 **Autograph Sessions** P C Hodgell Guy Gavriel Kay George R R Martin

DAY 2 - FRIDAY SEPT 2/94 - continued

- 11:00 MR 1 2C451 **How to Kill, Maim, or Heal Characters** How can one sword destroy an army? Here's help to ensure your science matches your story. Shariann Lewitt Bart Kemper Bridget McKenna Pras Stillman
- 11:00 MR 2 2C170 **A New Look at Hard SF** What is considered "hard" SF in today's market? How does it compare to what it has been in the past? David G Hartwell Kathryn Cramer
- 11:00 MR 4 2C739 **Interview with Anne McCaffrey** Elizabeth Ann Scarborough, co-writer with and friend of Anne McCaffrey, interviews Anne McCaffrey Elizabeth Ann Scarborough Anne McCaffrey
- 11:00 MR 6 2C581 **When I grow up, I want to be just like Wolverine** Canada's first superhero... Psycopath or Hero ??? Len Wein
- 11:00 MR 7 2C022 **Libraries in the Future** Will actual "paper" books become an anachronism with the advent of the electronic media? With easier access, might people read more, or has television killed the book industry? Lindalee Stuckey Billie Aul Laura Frankos Joseph T Mayhew Val Ontell
- 11:00 MR10 2C729 **Model Contest, First Session** Models on display in the Art Show. Sheila Adler Barry Adler
- 11:00 MR13 2C197 **Latest Japanese SF Art/Slide Show** Let Yasuo Kawai and Masamichi Osako show you the unknown Japanese SF Arts recently with beautiful slides! They will show you centered on the Art of Paperback covers, and talk about various artists. Yasuo Kawai Masamichi Osako Anthony Bryant
- 11:00 MR14 2C200 **How to Do Celtic Knotwork Workshop** Celtic knotwork is the ancient art of interlacing. Although it is beautifully intricate, it is deceptively simple to learn. In this workshop you will learn how to create a basic four strand knot which can be used as a border pattern or manipulated into more complex designs. Deb Kosiba
- 11:00 MR15 2C611 **Panel Moderation Workshop** Discussion and workshop on moderating skills. Recommended for all panel moderators. Frederick Andrew Lerner Tom Whitmore
- 12:00 ConCourse 2D802 **Autograph Sessions** Jonathan V. Post Jack L Chalker Sandra Morrese
- 12:00 MR 1 2D642 **WSFS Business Meeting, Preliminary Session** This meeting, held in three daily sessions starting today, is where we consider amendments to the WSFS Constitution (including the Hugo Awards and Worldcon Site Selection rules). At today's preliminary meeting, we will set debate time limits and other ground rules for debate on the motions submitted to this year's meeting. If you are a member of ConAdian, you are a member of WSFS and are welcome to attend this meeting and participate in the debate. Kevin Standlee
- 12:00 MR 2 2D621 **Fairy Tales and Folklore: Their Influence on SF** If folklore is really tales about a culture, how can a writer derive a story that is SF in feel? Lee Barwood Beth Meacham Claire Eddy Josepha Sherman Lindalee Stuckey
- 12:00 MR 4 2D552 **Invented Languages and Slangs** How do you invent a plausible language? Must you write a complete dictionary or are just a few words needed? Wil McCarthy Roger Burton-West Barry B Longyear Stanley Schmidt Kale Soley
- 12:00 MR 5 2D831 **KaffeeKlatsch** Limited ADVANCE Registration - Inquire at Con Info Desk. George Barr Edmund R. Meskys S. M. Stirling
- 12:00 MR 6 2D057 **Poetry Round-Robin Readings** Open to all who wish to participate. Mary Turzillo
- 12:00 MR 7 2D335 **Long-Term Future of the Universe** The past of the universe, all the way to the Big Bang, has been mapped out in fair detail. But what about the long-term future? How far ahead can we see, and what does the end look like for Earth, Sun Universe, and Humanity? Come and find out. Charles Sheffield
- 12:00 MR 8 2D177 **New Games** A friendly ice-breaker, in an atmosphere of pure fun, for children of all ages. Wear comfortable clothes and bring a sense of humor. David Honigsberg
- 12:00 MR 9 2D035 **How Anthologies are Put Together** We've all read them. How are they put together? Who picks a theme? And why the heck can't I get in one?!? Ellen Dattow Kevin J Anderson Briccio Barrientos Edward Kramer Mike Resnick
- 12:00 MR12 2D518 **Fan Funds Auction** Auction for a variety of good causes - Including (as of press time) TAFF, DUFF and the SF Foundation. Leah Zeldes Smith Richard Smith Jack L Chalker Mike Resnick Joe Haldeman Mike Glicksohn Jan Howard Jinder
- 12:00 MR13 2D103 **Maquerades** Famous costumes of the past from the cameras of Ray Lavender, Ken Konkol, David Clark and others; collected and presented by Marjii Ellers. Marjii Ellers

DAY 2 - FRIDAY SEPT 2/94 - continued

- 12:00 MR14 2D872 **Reading by Terry Garey** Terry Garey reads own work Terry Garey
- 12:00 MR15 2D014 **Enhancements to Humanity** When is the enhanced person no longer human? Where is your privacy when everybody has telepathy? Who would oppose the enhancements? Maia Cowan Glenn Grant J.D. Maynard Gerald D. Nordley Mary H Rosenblum
- 13:00 ConCourse 2E803 **Autograph Sessions** Joe Haldeman Kathryn Cramer Charles Sheffield
- 13:00 MR 2 2E639 **I Got Run Over by a Truck with NSA Plates on the Info Superhiway** How to survive the information superhighway. Timothy L Smith Bandit Brett Glass Robin Wulff
- 13:00 MR 4 2E740 **Babylon 5 Presentation** A sneak peak at what's in store for one of the best SF shows on TV! Craig Miller
- 13:00 MR 9 2E871 **Reading by Nancy Kilpatrick** Nancy Kilpatrick reads her own work. Nancy Kilpatrick
- 13:00 MR 7 2E656 **The Psychology of Writing** See what makes a writer tick. Why they do what they do and how they deal with their obsession. Barry B Longyear Jack Dann Alexandra Honigsberg John M. Landsberg Shariann Lewitt
- 13:00 MR 9 2E449 **The Encyclopedia of SF, My Two Years in Hell** The co-editor of "The Encyclopedia of Science Fiction" (a finalist in this year's non-fiction category of the Hugos), describes the tribulations, unexpected problems and occasional minor triumphs of researching a book that attempts to describe-without mistakes-the whole of SF in 1.3 million words. Peter Nicholls
- 13:00 MR10 2E458 **The Methods & Masochisms of Short Fiction Writing** What makes a story a story, and how do you keep it short? Richard Chwedyk Stephen Burns Teresa Patterson Mary H Rosenblum
- 13:00 MR13 2E055 **Planets of Double/Multiple Suns** The likelihood of planets in double and multiple star systems. Harry C Stubbs
- 13:00 MR14 2E597 **Slush Pile Panel** Excerpts from manuscripts the editors loved but for some silly reason just didn't buy. Dean Wesley Smith Kristine Kathryn Rusch Charles C Ryan Sue Weinlein Shawna McCarthy
- 13:00 MR15 2E327 **Canadian SF** A discussion on the differences in SF from various regions of the world. Robert Runte Glenn Grant David G Hartwell Andre Lieven Derryl Murphy Robert Sawyer Michael Skeet
- 14:00 ConCourse 2F804 **Autograph Sessions** Allen Steele Amy Thomson
- 14:00 MR 1 2F047 **Censorship Hitler burned books and Canada still controls the news.** When does political correctness lead to censorship? Caro Soles Myra Cakan Charles Pellegrino Ron Sarti Christine Valada
- 14:00 MR 2 2F574 **Using Humor to Make Social Statements** SF is a great medium for affecting social change and humor can be an efficient vehicle. Aren't sacred cows perfect for beef stew? Paula Johanson Phill Foglio Kaja Foglio Stephen Burns Susan Casper Hayford Peirce
- 14:00 MR 5 2F832 **KaffeeKlatsch** Limited ADVANCE Registration - Inquire at Con Info Desk. Jean Lorrach George R R Martin Len Wein
- 14:00 MR 7 2F874 **Reading by Frederik Pohl** Frederik Pohl reads his own work Frederik Pohl
- 14:00 MR 8 2F680 **Collating APA-NYU** A New York based monthly APA whose tradition it is to collate the September issue at Worldcon. (Issue # 232) Mark Glasser
- 14:00 MR 9 2F561 **Changing Paradigms on the Verge of the 21 Century** The world is changing faster now than 30 years ago. Are we keeping up? Dr. Arlan Andrews Maia Cowan Kathleen Ann Goonan Bradford Lyau Henry Vanderbilt
- 14:00 MR10 2F696 **Global Warming** A discussion on global warming and how it will affect our lives in the next century. Timothy Lane Clifton Amsbury Gerald D. Nordley John Strickland Jr.
- 14:00 MR13 2F718 **Transylvania Tour** A slide show of Transylvania in two parts. The first part as seen through the eyes of Bram Stoker's characters in Dracula. The second part covers the life of Vlad the Impaler, the real life 15th century prince who impaled his enemies. Beverley Richardson
- 14:00 MR14 2F873 **Reading by Donald Kingsbury** Donald Kingsbury reads his own work. Donald Kingsbury
- 14:00 MR15 2F777 **That Krazy Kepler....Basic Astronomy from the Past** Kepler, as performed by Dr. Martin Clutton-Brock, tells the audience how he made his discoveries, all the while battling nagging wives, drunken roommates and stupid bureaucracy. Dr. Martin Clutton-Brock
- 15:00 ConCourse 2G805 **Autograph Sessions** Jean-Louis Trudel Gene Wolfe

TIME	MEETING ROOM 1	MEETING ROOM 2	MEETING ROOM 4	MEETING ROOM 5	MEETING ROOM 6	MEETING ROOM 7	MEETING ROOM 8	MEETING ROOM 9	MEETING ROOM 10	MEETING ROOM 12	MEETING ROOM 13	MEETING ROOM 14	MEETING ROOM 15	MEETING ROOM 16	CAMP SOUTH	OTHER LOCATIONS	TIME
9:00																	9:00 AM
10:00																	10:00 AM
11:00																	11:00 AM
12:00																	12:00 PM
13:00																	1:00 PM
14:00													How to Enjoy Your First WorldCon	Filk Concert		Opening Ceremonies - HALL "B"	2:00 PM
15:00	1973 Worldcon Remembered	Genre Crossing											Getting From Manuscript to Finished Product	Filk Concert			3:00 PM
16:00	1997 Worldcon Bid Presentations	The Technology of Magic				Living With a Writer		German SF			SF Origins			Filk Concert			4:00 PM
17:00	Is It Fantasy If You Rip It Off From Hist	Never Make It Easy On Your Hero/Heroine	Should SF Have Rivets?			Interview of Barry Longyear					Virtual Reality	Hands-On Parliamentary Procedure Workshop		Writing Parody / Humor			5:00 PM
18:00																	8:00 PM
19:00																Mark Protection Comm. - West	7:00 PM
20:00						Tarot Workshop		Enterprise 2067				8:30 Jam - Songs of Science Fiction	9:30 Open Filking	8:30 Open Drum Jam		Spiders' Place - Norwood Hotel	8:00 PM
21:00	Sources of Fear in Horror								Star Trek: Parody, Standard Orbit Players		Alternate Histories	9:30 Open Filking					9:00 PM
22:00											So you've been taken aboard a UFO			9:30 Open Filking			10:00 PM
23:00	Urban/Dark Fantasy																11:00 PM

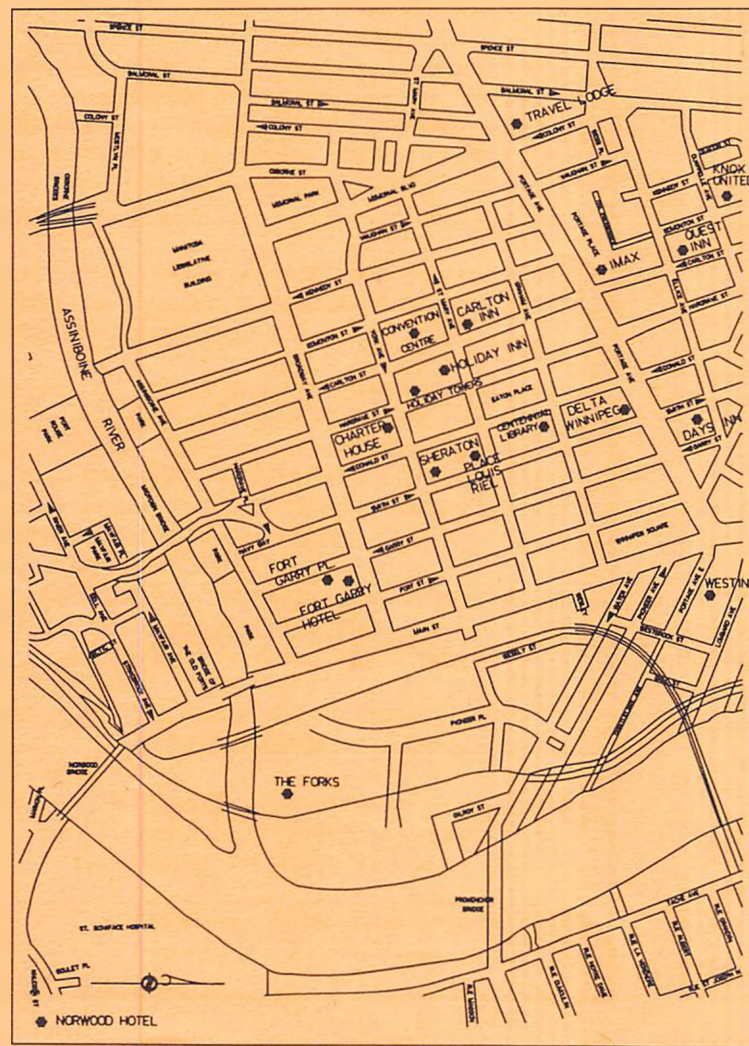

CONVENTION CENTRE

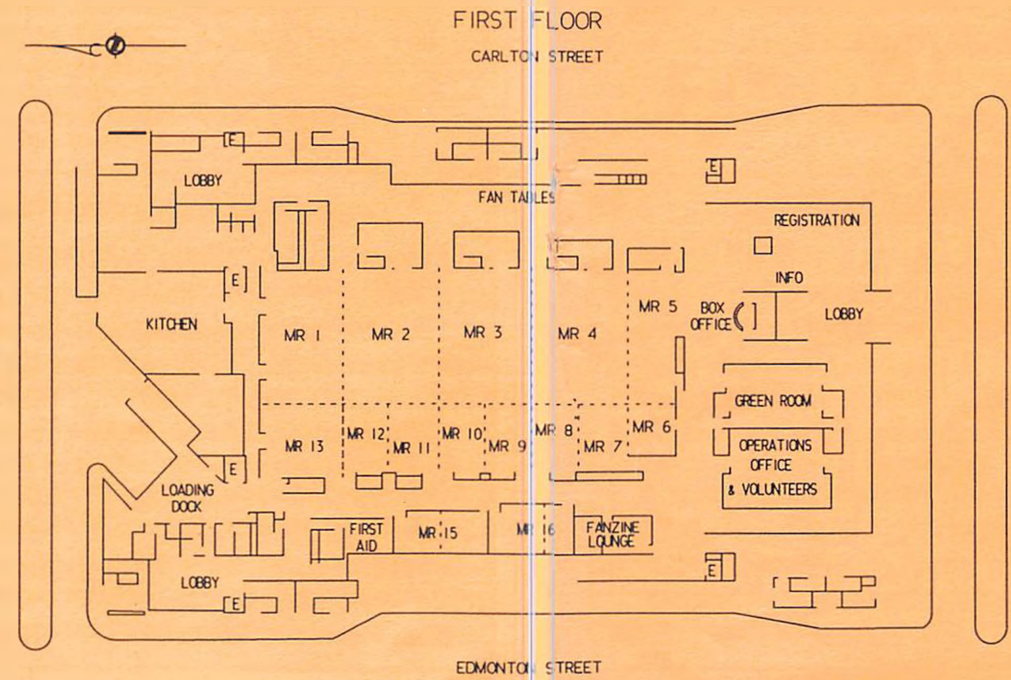

SECOND FLOOR

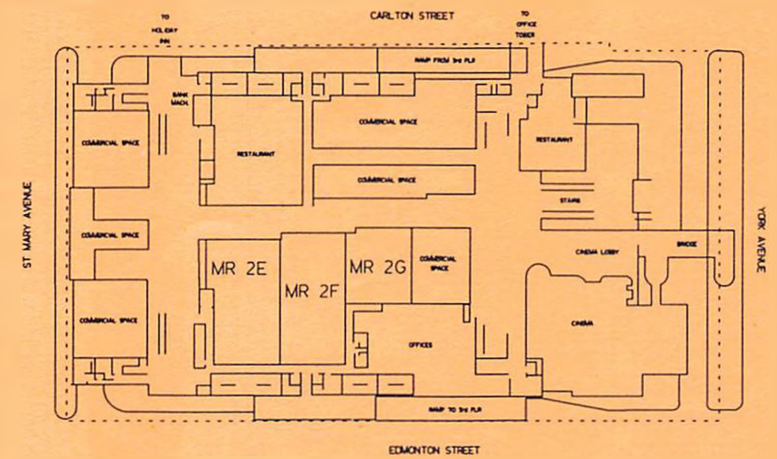

THIRD FLOOR

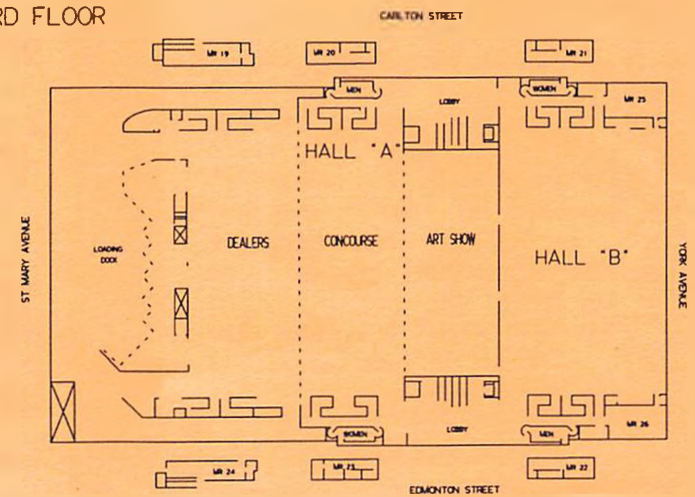

FILK PROGRAM SCHEDULE

- 02:00-02:30 MR16 Concert, Decadent Dave Clement
 02:30-03:00 MR16 Concert Stephanie Bedwell-Grime
 03:00-03:30 MR16 Concert, John Speelman
 03:30-04:00 MR16 Concert, Kate Soley
 04:00-04:30 MR16 Concert, Graham Leathers
 04:30-05:00 MR16 Concert, Judith Hayman
 05:00-06:00 MR16 Panel, Writing parody / humour
 Diane Sankey, Roberta Rogow, Graham Leathers, Brett Glass Panelists discuss how they go about putting a humorous bent in their songs.
 08:30-10:30 MR16 Open drum jam
 08:30—9:30 MR14 Jam, Songs of Science Fiction
 sign up in the Filk Lounge
 08:30—> MR15 Open filking
 09:30—> MR14 Open filking
 10:30—> MR16 Open filking

ART SHOW The Art show is located in Hall "A" on the third floor of the Convention Centre

Thursday	Sept. 1	12 pm - 7 pm
Friday	Sept. 2	11 am - 7 pm
Saturday	Sept. 3	11 am - 7 pm
Sunday	Sept. 4	11 am - 2 pm 6 pm - 8 pm
Monday	Sept. 5	9 am - 3 pm

AUTOGRAPH SESSIONS The Autograph sessions are taking place Friday through Sunday in the Concourse area near the Art Show and Dealers Room. The number of books you can bring may be limited by each author. Presently the only limit we know of is 2 for Anne McCaffrey... other limits will be posted on the bulletin board by the session area.

Please be considerate of others and do not bring boxes full of books for autographing by one author, or bring multiple copies for resale. We appreciate your cooperation.

BLOOD DRIVE A blood drive will be held at the Red Cross building on Saturday, September 3 from 9 am - 5 pm. A van will pick up people at 10 am and 11 am to take them to 226 Osborne N. (Red Cross Building). Maps will be available at the information desk for those who wish to walk. Bring your photo ID with you and don't forget to eat before you go to donate blood.

CONSUIE KON-IVAL We are the consuite, located in the Riel Room in the Place Louis Riel Hotel. Open 10 am - 2 pm and 4 pm - 4 am with special features daily. Come one come all!!!

DEALERS ROOM The Dealers Room is located in Hall "A" on the third floor of the Convention Centre.

Thursday	Sept. 1	12 pm - 6 pm
Fri. - Sun	Sept. 2 - 4	10 am - 6 pm
Monday	Sept. 5	10 am - 3 pm

EXHIBITS Exhibits are located in Hall "A" on the third floor of the Convention Centre.

THURSDAY PROGRAM SCHEDULE

- 14:00 HALL "B" **Opening Ceremonies** Doors open at 1 pm ConAdian will host a show with local and fannish activities, including the traditional welcoming speeches and introductions. Barry B. Longyear serves as this year's Master of Ceremonies so drop by and welcome in the 52nd World Science Fiction Convention.
- 14:00 MR15 1F516 **How to Enjoy Your First WorldCon** So you took the Big Step and came. Here's some help in making yours a great convention. Kathei Logue Bill Farina Jan Howard Inder David W Clark Leah Zeldes Smith Richard Smith Robin Wulff
- 15:00 MR 1 1G646 **1973 Worldcon Remembered** Torcon!!!... Toronto 1973... The site, the smells, the convention. Will time ever tell us what really happened? Or will we just make it all up. Ken Smookler
- 15:00 MR 2 1G134 **Genre Crossing When is an SF story not an SF story?** Joe Haldeman Dr. Janice Bogstad Adrienne Foster Peter J Heck Ron Sarti
- 15:00 MR15 1G002 **Steps in Getting From Manuscript to Finished Book** Does the "finished book" exist? Should "finished book" become an anachronism? What comes after the finished book? Kathryn Cramer ~~Kristine Kathryn Rusch~~ Richard Knaak ~~Dean Wesley Smith~~ Dr. William Sarjeant Shelly Shapiro Moshe Feder
- 16:00 MR 1 1H640 **1997 Worldcon Bid Presentations** Before you vote, take one good last look at those who want to host the 1997 Worldcon. Mike Glyer
- 16:00 MR 2 1H615 **The Technology of Magic** Are there any universal rules? How can you keep the magic consistent? How much can you borrow? Greg Costikyan Maia Cowan Jack L Chalker Julia Martin Edmund R. Meskys Harry C Stubbs
- 16:00 MR 7 1H006 **Living With a Writer** Is living with a writer like living alone? Are all writers insane? The ups and downs of living with a writer. Christine Valada Jeremy Bloom Richard Chwedyk Carolyn Clink Laura Frankos
- 16:00 MR 9 1H051 **German SF** German SF: A short market report. Who publishes SF after four out of six publishing houses (pocket books) closed their SF section in 1986? What goes on SF-wise besides books, like movies (The High Crusade) and the Fantasy Filmfest? Myra Cakan Waldemar Kumming
- 16:00 MR13 1H096 **SF Origins** Are we running the Chicken and the Egg theory again? How did SF begin? Bradford Lyau David Kyle Arthur Kyle Jean-Louis Trudel Ariane Von Orlow
- 17:00 MR 1 1I633 **Is It Fantasy If You Rip It Off From History** How to use history to help shape a good fantasy story. Anthony Bryant Roger Burton-West Sasha Miller Kate Soley
- 17:00 MR 2 1I614 **Never Make It Easy On Your Hero/Heroine** After all, what kind of hero is he if he lives in Care Bear Land? Jean Lorrach Shariann Lewitt Geoff Ryman K. D. Wentworth
- 17:00 MR 4 1I017 **Should SF Have Rivets?** Everything in life and beyond has a structure, but must we know the "science" behind every facet of existence? Ken Meltsner Jonathan V. Post Maia Cowan Bart Kemper Allen Steele

EXTRAVAGANZAS & EVENTS

Opening Ceremonies Thursday, 2pm Hall B Doors open at 1 pm ConAdian will host a show with local and fannish activities, including the traditional welcoming speeches and introductions. Barry B. Longyear serves as this year's Master of Ceremonies so drop by and welcome in the 52nd World Science Fiction Convention.

Spider's Place Thursday, 8pm Norwood Hotel. Join Spider Robinson as he hosts an evening of nonfilk music at the Norwood Hotel. Join other fans and pro's as they try to impress one another with their musical talent. Participants will play half-hour sets before jamming together.

17:00 MR7 *Interview of Barry Longyear (John Mansfield)*

17:00 MR13 1I236 **Virtual Reality** How real can it be if you can't touch it? A discussion of VR and how it can work for you. Dr. Arlan Andrews Ashley D Grayson Jack Nimersheim Perry Mark Stratyckuk Amy Thomson

17:00 MR14 1I361 **Hands-On Parliamentary Procedure Workshop** An introduction to parliamentary procedure and Robert's Rules of Order, the rules which govern the WSFS Business Meeting. We'll cover basic procedure, with special emphasis on procedures you'll see at most WSFS Meetings. If you've ever wanted to participate in the WSFS Business Meeting, but felt intimidated by the procedural rules, you'll want to attend this meeting. Kevin Standlee

19:00 Norwood Hotel 1L741 **Spider's Place** This year's non filk musical extravaganza - 1/2 hour sets of mostly accoustic music. Entertainers include Joe Haldeman, Peter Heck, Tam Gordye... Spider Robinson Jeanne Robinson

19:00 WEST 1K641 **Mark Protection Committee Meeting** The WSFS Mark Protection Committee administers the service marks on "Worldcon", "Hugo Awards", and the other WSFS marks. This committee meeting is open to all members of ConAdian, seating permitting. The committee will consider its report to the WSFS Business Meeting Kevin Standlee

20:00 MR 7 1L009 **Tarot Workshop** Basic workshop for beginners. Covers choosing, initiating, and maintaining a deck. Also what to do when a deck goes "bad". Sunnie Andreu

20:00 MR 9 1L675 **Enterprise 2067** Bent Science Demonstration: We came in peace for all mankind-future space conquistadors will have to make ships which can fight in space. The lecture and demo is on how to design and build a real interplanetary cruiser. David Stephenson

20:00 Norwood Hotel **Spider's Place** Join Spider Robinson as he hosts an evening of nonfilk music at the Norwood Hotel. Join other fans and pro's as they try to impress one another with their musical talent. Participants will play half-hour sets before jamming together.

21:00 MR 1 1M619 **Sources of Fear in Horror** It's fun to be scared from time to time. Here's how the writer can create mood, schock, and suspense. William R. Lund Beverley Richardson

21:00 MR12 1M348 **Star Trek Parody**, Ahead warp speed with the Standard Orbit Players and their Star Trek presentation. It's funny, it's irreverent; it will make Spock blush to the tips of his pointed ears. Lance Sibley

21:00 MR13 1M015 **Alternate Histories** If you could change one event in the past, how would today's history change? What are the rules of alternate histories? Ginjer Buchanan Glenn Grant Philip Kaveny Evelyn Leeper Allen Steele Harry C Stubbs

22:00 MR13 1M782 **So You've Been Taken Aboard a UFO!** An Etiquette Guide for Abductees. Remember: When greeting an unknown species, shake only the proferred tentacle. Chris Rutkowski

23:00 MR 1 1O075 **Urban/Dark Fantasy** We see it in the paper and on the nightly news. Are we as a culture fascinated with Death? Stephanie Bedwell-Grime Stephen Dedman Dawn Dunn Terry O'Brien Dale Sproule Richard Knaak

PROGRAM ROOM LOCATIONS

HALL "B" - 3rd floor of the Wpg Convention Center
MR 2EFG - 2nd floor of the Wpg Convention Center
MR 1 thru 15 - 1st floor of the Wpg Convention Center
WEST - Westminster Room West 2nd floor Holiday Inn
Concourse - 3rd floor of the Wpg Convention Center
Con Cont Loop - WCC outside main entrance 1st floor
CAMP-S - Campaign rm "South" 2nd floor Holiday Inn
Science Channel Videos - 5th flr Charter House Hotel
Japanese Animation - Lower Level Charter House Hotel
British Video Room - 3rd flr Charter House Hotel
Writers Workshops - Sheraton Hotel
Gaming - Place Louis Reil

NOTES

TIME	MEETING ROOM 1	MEETING ROOM 2	MEETING ROOM 4	MEETING ROOM 5	MEETING ROOM 6	MEETING ROOM 7	MEETING ROOM 8	MEETING ROOM 9	MEETING ROOM 10	MEETING ROOM 12	MEETING ROOM 13	MEETING ROOM 14	MEETING ROOM 15	MEETING ROOM 16	CAMP SOUTH	OTHER LOCATIONS	TIME	
9:00							Aerobics									N3F Breakfast - Fort Garry	9:00 AM	
10:00	The Business of Writing			KaffeeKatsch		Solar Power Satellites and Energy Politics		Origami Workshop	Reading by Heather Spears	Debunking Pseudoscience		Society for the Preservation of SF Fandom	Starting a New Convention		ASFA Meeting	Blood Drive - Con Centre Loop	10:00 AM	
11:00	How to Kill, Maim, or Heal Characters	A New Look at Hard SF	Interview with Anne McCaffrey		When I grow up, I want to be just like Wolverine	Libraries in the Future			Model Contest, First Session		Latest Japanese SF Art/Slide Show	How to Do Celtic Knotwork Workshop	The Art of Planning & Moderating Panels	Workshop Performance skills			11:00 AM	
12:00	AWFS Business Meeting, Preliminary Sessio	Fairy Tales and Folklore - Their Influence	Invented Languages and Slangs	KaffeeKatsch	Poetry Round Robin	Long-Term Future of the Universe	New Games	How Anthologies are Put Together			Fan Funds Auction	Maquerades	Reading by Terry Garey	Enhancements to Humanity			12:00 PM	
13:00		I Got Run Over by a Truck with NSA Plates	Babylon 5 Presentation		Reading by Nancy Kilpatrick	The Psychology of Writing		The Encyclopedia of SF, My Two Years in Hell	The Methods & Masochisms of Short Fiction		Planets of Double/Multiple Suns	Slush Pile Panel	Canadian SF	Filk Concerts			1:00 PM	
14:00	Censorship	Using Humor to Make Social Statements		KaffeeKatsch	The Archeology of Slasher Films	Reading by Frederik Pohl	Collating APA-NYU	Changing Paradigms on the Verge of the 21	Global Warming		Transylvania Tour	Reading by Donald Kingsbury	That Krazy Kepler - Basic Astronomy	see Filk Program	Pegasus Awards		2:00 PM	
15:00	Pern Trivia/Hosting	Babylon Five Panel	World Building		INP'S Meeting	Magic Meets Technology		Soviet Space Disasters	How to Form a Writer's Group		Bantam Books Presents	Wpg Doctor Who/Blake's 7 Fan Club, Club Mng	Reading by Connie Willis	Workshop, Song writing - Intro			3:00 PM	
16:00	To Be a Female Writer	Can Technology Help Us Save/Manage Our Wo	The Use of Science in Fantasy	KaffeeKatsch		Reading by Kathleen Ruesch		Designing Diseases	How to Edit	What is Magic, the Game?	Musing with Muuse (tm)- Applications of VR		OnLine Communities	Workshop, Voice			4:00 PM	
17:00	Pren Trivia Contest	Is Modern SF A Reactionary Literature?				Christian Fandom Meeting	Reading by S.M. Sterling	Being A Pagan in Professional Society	Introduction to Play-by-Mail Gaming	Bheer Home-Brewing	So What's A Science Fiction 'Garage' Kit?	Balancing Writing With Family	Books through the Internet	Workshop, Filk instrumentation			5:00 PM	
18:00																GATHER 7:30PM RMS 2EFG	6:00 PM	
19:00	What to do When Universal Translator Breaks down	The Matching															REGENCY DANCE 8:30PM RMS 2EFG	7:00 PM
20:00						Electronic Publishing				Trends in Horror	Getting Off the Rock	Filk in the UK 8:30	Workshop, Filk instrumentation 8:30 - 10:30	Jam, songs of Start Trek 8:30 - 10:30			8:00 PM	
21:00		Star Trek Parody			Jewish Sabbath Services	What Should Have Made it on the Hugo Ball				Star Trek Parody, Standard Orbit Players	How to Design Credible Aliens	Jam, Filk International 8:30					9:00 PM	
22:00						Pictionary: Artists Vrs Authors					Bad Movies	Open Filking 10:30	Open Filking 10:30	Open Filking 10:30			10:00 PM	
23:00						PC/Multiculturalism and its Influence on SF				Vampires: Fact, Fiction, and Myth							11:00 PM	
24:00						Midnight Horror Readings											12:00 AM	

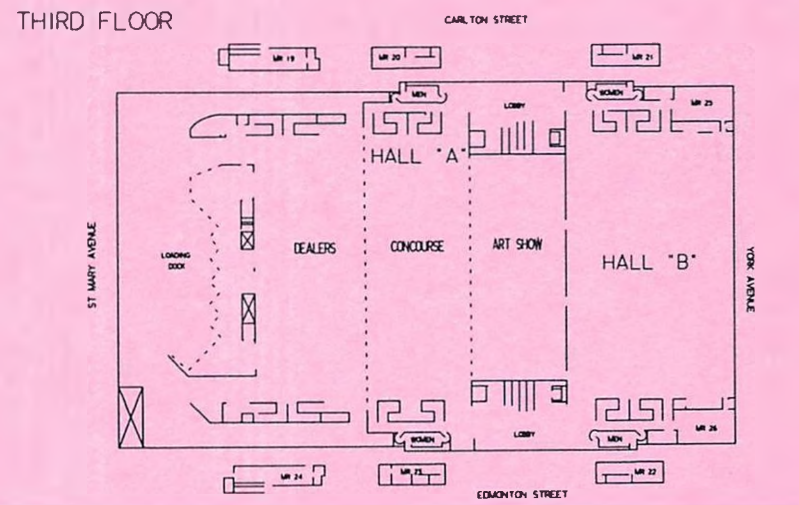
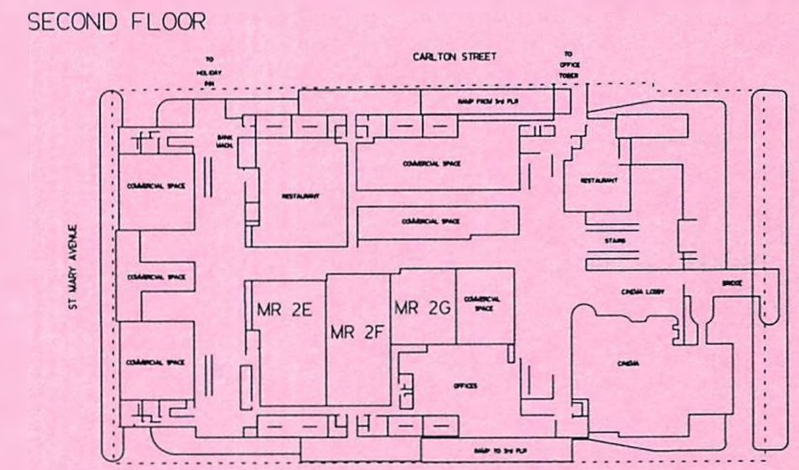
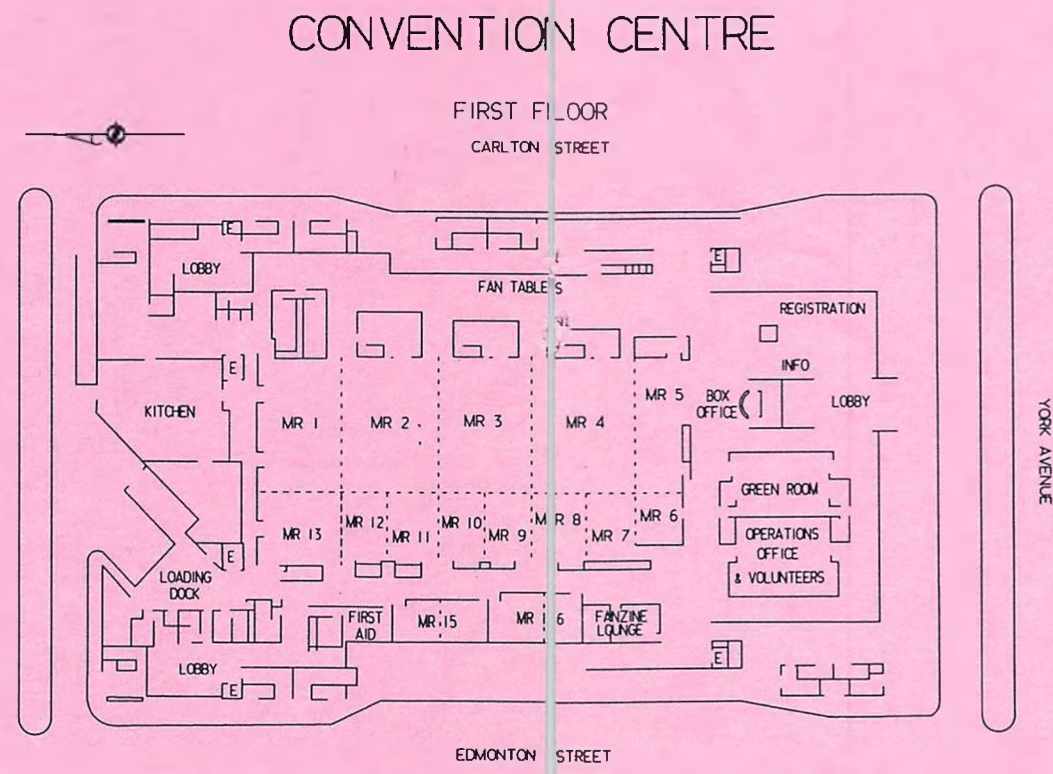
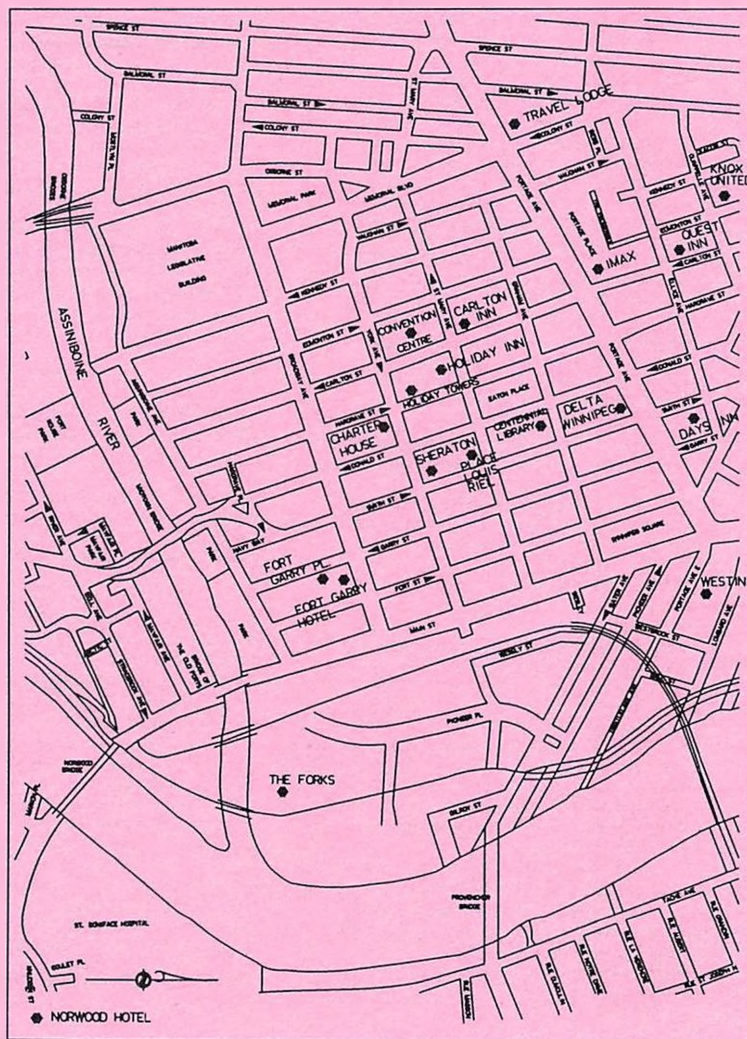

FILK PROGRAM SCHEDULE

- 11:00-12:00 MR16 Workshop, Performance skills w/Kathy Mar sign-up in Filk Lounge
- 12:00-12:30 MR16 Concert, Andrea Yeomans
- 12:30-01:00 MR16 Concert, Roberta Rogow
- 01:00-01:30 MR16 Concert, Jordin Kare
- 01:30-02:00 MR16 Concert, Diane Sankey & Sylvia Fisher
- 02:00-03:00 CAMP-S Panel, Pegasus Awards, listen & vote Glenn Simser
- 02:00-02:30 MR16 Concert, Nate Bucklin
- 02:30-03:00 MR16 Concert, Mary Ellen Wessels
- 03:00-04:00 CAMP-S Workshop, Song Writing - introductory Lynn Gold, Graham Leathers, Allison Durno, Judith Hayman Song writing 101, for those who think they can't write a song.
- 03:00-03:30 MR16 Concert, Kathy Mar
- 03:30-04:00 MR16 Concert, Bill Roper
- 04:00-05:00 CAMP-S Workshop, Voice Mary Ellen Wessels, Dave Clement Tips on breathing right and other fine points in the use of voice,
- 04:00-04:30 MR16 Concert, Pete Grubbs
- 04:30-05:00 MR16 Concert, Roger Burton-West
- 05:00-06:00 CAMP-S Workshop, Filk instrumentation - guitar Joey Shoji, Pete Grubbs, Nate Bucklin Picking and strumming tips from some of the best.
- 05:00-06:00 MR16 Concert, Urban Tapestry
- 08:30-09:30 MR14 Panel, Filk in the U.K. Kate Soley, Roger Burton-West, Kathy Mar What happening in the overseas filk community.
- 08:30-10:30 MR16 Jam, Songs of Star Trek Judith Hayman, Urban Tapestry, Glenn Simser, Kathleen Sloan, Roberta Rogow
- 08:30-10:30 MR15 Workshop, Filk instrumentation, assorted instruments Banjo: Graham Leathers, cittern & dulcimer: Tom Jeffers, flute/recorder/pennywhistle: Kylea Fulton, bass: Brett Glass, omnichord: Roger Burton-West, There is more to filk music than just guitar and voice.
- 09:30-10:30 MR14 Jam, Filk International Kate Soley, Graham Leathers, Pete Grubbs
- 10:30 → MR14 Open filking
- 10:30 → MR16 Open filking
- 10:30 → MR15 Open filking

PROGRAM ROOM LOCATIONS

- HALL "B"** - 3rd floor of the Wpg Convention Center
- MR 2EFG** - 2nd floor of the Wpg Convention Center
- MR 1 thru 15** - 1st floor of the Wpg Convention Center
- WEST** - Westminister Room West 2nd floor Holiday Inn
- Concourse** - 3rd floor of the Wpg Convention Center
- Con Cont Loop** - WCC outside main entrance 1st floor
- CAMP-S** - Campaign rm "South" 2nd floor Holiday Inn
- Science Channel Videos** - 5th flr Charter House Hotel
- Japanese Animation** - Lower Level Charter House Hotel
- British Video Room** - 3rd flr Charter House Hotel
- Writers Workshops** - Sheraton Hotel
- Gaming** - Place Louis Reil

EXTRAVAGANZAS / EVENTS

- The Gather** Friday, 7:30 pm Rm2EFG In honour of guest-of-honour Anne McCaffrey, we are presenting a Pernese Gather with dragon decorations and a variety of performer's and dancers in proper Pernese tradition. Pernese refreshments will be served to guests. There will be prizes awarded in various categories relevant to the evening - so dress in your finest costumes.
- Regency Dance** Friday MR 1 8:30pm, The English Regency period (about the year 1800) was a colorful, whimsical time that appeals to the fannish sense of humor.

FRIDAY PROGRAM SCHEDULE

- 09:00 Fort Garry Hotel 2A767 **NJF Breakfast** A dutch treat breakfast. Diane Miller
- 09:00 MR 8 2A080 **Aerobics** Exercise for the fanish masses. John Douglass
- 10:00 ~~CAMP-S~~ **ASFA Meeting** Annual meeting of the SF/F Artists association.
- 10:00 Con Cir Loop 2B761 **Blood Drive** Since the dawn of time Worldcons have had Blood Drives, Canadian will be no different. The Red Cross will provide a bus on Friday, September 2nd. It will run at the hours of 10am and 11am. Pick up is in the loop in front of the Convention Centre. Photo ID is required to donate, and it is asked that donors eat before hand.
- 10:00 ConCourse 2B800 **Autograph Sessions** Jean Lorrach Elizabeth Moon Jody Lynn Nye
- 10:00 MR 1 2B007 **The Business of Writing** Can you survive writing SF alone? Should you concentrate on the "art" and leave the business to an agent? Are you in it just for the money? Dave Wolverton Ian Ballantine Betty Ballantine Rebecca Moesta Anderson M Shayne Bell L Warren Douglas David Feintuch
- 10:00 MR 5 2B830 **KaffeeKlatsch** Limited ADVANCE registration - inquire at Con Info Desk Alan Barclay Donald Kingsbury George (Lan) Laskowski Larry Niven Elisabeth Vonarburg
- 10:00 MR 7 2B519 **Solar Power Satellites and Energy Politics** Let's take a look at solar power via the slide projector. John Strickland Jr.
- 10:00 MR 9 2B221 **Origami Workshop** Mark will teach folding figures the attendees choose from a selection of simple, intermediate, and difficult paperfolds. Subjects include dinosaurs, aliens, spacecraft, etc. Attendees are encouraged to show and teach figures of their own and to experiment. Most of the figures that Mark teaches are his own inventions. Featured: X-wing fighter Mark Leeper
- 10:00 MR10 2B870 **Reading by Heather Spears** Heather Spears reads her own work. Heather Spears
- 10:00 MR12 2B520 **Debunking Pseudoscience** Most SF writers knowingly use pseudoscience. Where do we draw the line? Jack Nimersheim George Flentke Hayford Pearce Howard Scrimgeour Susan M Smith Keith G. Kato
- 10:00 MR14 2B748 **Society for the Preservation of SF** Fandom History Dedicated to the physical preservation of endangered fannish materials. Networking, cataloging resources and idea sharing encouraged! Peggy Rae Pavlat
- 10:00 MR15 2B638 **Starting a New Convention** How and why some cons were started, how they have been maintained, and a few of the problems they had to fix along the way. Cindy Huckle Franklin Hummel Val Ontell Robert Runte Sue Weinlein
- 11:00 ConCourse 2C801 **Autograph Sessions** P C Hodgell Guy Gavriel Kay George R R Martin
- 11:00 MR 1 2C451 **How to Kill, Maim, or Heal Characters** How can one sword destroy an army? Here's help to ensure your science matches your story. Shariann Lewitt Bart Kemper Bridget McKenna Pras Stillman
- 11:00 MR 2 2C570 **New Look at Hard SF** What is considered "hard" SF in today's market? How does it compare to what it has been in the past? David G Hartwell Kathryn Cramer
- 11:00 MR 4 2C739 **Interview with Anne McCaffrey** Elizabeth Ann Scarborough, co-writer with and friend of Anne McCaffrey, interviews Anne McCaffrey Elizabeth Ann Scarborough Anne McCaffrey
- 11:00 MR 6 2C581 **When I grow up, I want to be just like Wolverine** Canada's first superhero... Psychopath or Hero ??? Len Wein
- 11:00 MR 7 2C022 **Libraries in the Future** Will actual "paper" books become an anachronism with the advent of the electronic media? With easier access, might people read more, or has television killed the book industry? Lindalee Stuckey Billie Aul Laura Frankos Joseph T Mayhew Val Ontell
- 11:00 MR10 2C729 **Model Contest, First Session**, Models on display in the Art Show. Sheila & Barry Adler
- 11:00 MR13 2C197 **Latest Japanese SF Art/Slide Show** Let Yasuo Kawai and Masamichi Osako show you the unknown Japanese SF Arts recently with beautiful slides! They will show you centered on the Art of Paperback covers, and talk about various artists. Yasuo Kawai Masamichi Osako Anthony Bryant
- 11:00 MR13 2C611 **Panel Moderation Workshop** Frederick Andrew Lerner Tom Whitmore
- 11:00 MR14 2C200 **How to Do Celtic Knotwork Workshop** Celtic knotwork is the ancient art of interlacing. Although it is beautifully intricate, it is deceptively simple to learn. In this workshop you will learn how to create a basic four strand knot which can be used as a border pattern or manipulated into more complex designs. Deb Kosiba
- 12:00 ConCourse 2D802 **Autograph Sessions** Jonathan V. Post Jack L Chalker Sandra Morrese

- 12:00 MR 1 2D642 **WSFS Business Meeting, Preliminary Session** This meeting field in three daily sessions starting today, is where we consider amendments to the WSFS Constitution (including the Hugo Awards and Worldcon Site Selection rules). At today's preliminary meeting, we will set debate time limits and other ground rules for debate on the motions submitted to this year's meeting. If you are a member of ConAdia, you are a member of WSFS and are welcome to attend this meeting and participate in the debate. Kevin Standlee
- 12:00 MR 2 2D621 **Fairy Tales and Folklore: Their Influence on SF.** If folklore is really tales about a culture, how can a writer derive a story that is SF in feel? Lee Barwood Beth Meacham Claire Eddy Josepha Sherman Lindalee Stuckey
- 12:00 MR 4 2D552 **Invented Languages and Slangs** How do you invent a plausible language? Must you write a complete dictionary or are just a few words needed? Wil McCarthy Roger Burton-West Barry B Longyear Stanley Schmidt Kate Soley
- 12:00 MR 5 2D831 **KaffeeKlatsch** Limited ADVANCE Registration - Inquire at Con Info Desk. George Barr Edmund R. Meskys S. M Stirling
- 12:00 MR 6 2D057 **Poetry Round-Robin Readings** Open to all who wish to participate. Mary Turzillo
- 12:00 MR 7 2D335 **Long-Term Future of the Universe** The past of the universe, all the way to the Big Bang, has been mapped out in fair detail. But what about the long-term future? How far ahead can we see, and what does the end look like for Earth, Sun Universe, and Humanity? Come and find out. Charles Sheffield
- 12:00 MR 8 2D177 **New Games** A friendly ice-breaker, in an atmosphere of pure fun, for children of all ages. Wear comfortable clothes and bring a sense of humor. David Honigsberg
- 12:00 MR 9 2D035 **How Anthologies are Put Together** We've all read them. How are they put together? Who picks a theme? And why the heck can't I get in one?? Ellen Dattow Kevin J Anderson Briccio Barrientos Edward Kramer Mike Resnick
- 12:00 MR12 2D518 **Fan Funds Auction** Auction for a variety of good causes - including (as of press time) TAFF, DUFF and the SF Foundation. Leah Zeldes Smith Richard Smith Jack L Chalker Mike Resnick Joe Haldeman Mike Glicksohn Jan Howard Finder
- 12:00 MR13 2D103 **Maquerades** Famous costumes of the past from the cameras of Flay Lavender, Ken Konkol, David Clark and others; collected and presented by Marjii Eilers. Marjii Eilers
- 12:00 MR14 2D872 **Reading by Terry Garey** Terry Garey reads own work. Terry Garey
- 12:00 MR15 2D014 **Enhancement to Humanity** When is the enhanced person no longer human? Where is your privacy when everybody has telepathy? Who would oppose the enhancements? Maia Cowan Glenn Grant J.D. Maynard Gerald D. Nordley Mary H Rosenblum
- 13:00 ConCourse 2E803 **Autograph Sessions** Joe Haldeman Kathryn Cramer Charles Sheffield
- 13:00 MR 2 2E639 **I Got Run Over by a Truck with NSA Plates on the Info Superhighway** How to survive the information superhighway. Timothy L Smith Bartlett Brett Glass Robin Wulf Seth Brubaker
- 13:00 MR 4 2E740 **Babylon 5 Presentation** A sneak peak at what's in store for one of the best SF shows on TV! Craig Miller
- 13:00 MR 6 2C871 **Reading by Nancy Kilpatrick** Nancy Kilpatrick reads her own work. Nancy Kilpatrick
- 13:00 MR 7 2E656 **The Psychology of Writing** See what makes a writer tick. Why they do what they do and how they deal with their obsession. Barry B Longyear Jack Dann Alexandra Honigsberg John M. Landsberg Shariann Lewitt
- 13:00 MR 9 2E449 **The Encyclopedia of SF, My Two Years in Hell** The co-editor of The Encyclopedia of Science Fiction" (a finalist in his year's non-fiction category of the Hugos), describes the tribulations, unexpected problem and occasional minor triumphs of researching a book that attempts to describe-without mistakes-the whole of SF in 1.3 million words. Peter Nicholls
- 13:00 MR10 2E458 **The Methods of Masochisms of Short Fiction Writing** What makes a story a story, and how do you keep it short? Richard Chwedyk Stephen Burns Teresa Paterson Mary H Rosenblum
- 13:00 MR13 2E055 **Planets of Double/Multiple Suns** The likelihood of planets in double and multiple star systems. Harry C Stubbs

- 13:00 MR14 2E597 **Slush Pile Panel** Excerpts from manuscripts the editors loved but for some silly reason just didn't buy. Dean Wesley Smith Kristine Kathryn Rusch Charles C Ryan Sue Weinlein Shawna McCarthy ~~Josypha Sherman~~
- 13:00 MR15 2E327 **Canadian SF** A discussion on the differences in SF from various regions of the world. Robert Runte Glenn Grant David G Hartwell Andre Lieven Derryl Murphy Robert Sawyer Michael Skeet
- 14:00 ConCourse 2F804 **Autograph Sessions** Allen Steele Amy Thomson
- 14:00 MR 1 2F047 **Censorship Hitler burned books and Canada still controls the news.** When does political correctness lead to censorship? Caro Soles Myra Cakan Charles Pellegrino Ron Sarti Christine Valada
- 14:00 MR 2 2F574 **Using Humor to Make Social Statements** SF is a great medium for affecting social change and humor can be an efficient vehicle. Aren't sacred cows perfect for beef stew? Paula Johanson Phill Foglio Kaja Foglio Stephen Burns Susan Casper Hayford Pearce
- 14:00 MR 5 2F832 **KaffeeKlatsch** Limited ADVANCE Registration - Inquire at Con Info Desk. Jean Lorrach George R R Martin Len Wein
- 14:00 MR 7 2F874 **Reading by Frederik Pohl** Frederik Pohl reads his own work. Frederik Pohl
- 14:00 MR 8 2F680 **Collating APA-NYU** APA-NYU is a New York based APA whose tradition is to collate the September issue at the Worldcon. Mark Glasser
- 14:00 MR 9 2F561 **Changing Paradigms on the Verge of the 21st Century** The world is changing faster now than 30 years ago. Are we keeping up? Dr. Arlan Andrews Maia Cowan Kathleen Ann Goonan Bradford Lyau Henry Vanderbilt
- 14:00 MR10 2F696 **Global Warming** A discussion on global warming and how it will affect our lives in the next century. Timothy Lane Clifton Amsbury Gerald D. Nordley John Strickland Jr.
- 14:00 MR13 2F718 **Transylvania Tour** A slide show of Transylvania in two parts. The first part as seen through the eyes of Bram Stoker's characters in Dracula. The second part covers the life of Vlad the Impaler, the real life 15th century prince who impaled his enemies. Beverley Richardson
- 14:00 MR14 2F873 **Reading by Donald Kingsbury** Donald Kingsbury reads his own work. Donald Kingsbury
- 14:00 MR15 2F777 **That Crazy Kepler....Basic Astronomy from the Past** Kepler, as performed by Dr. Martin Clutton-Brock, tells the audience how he made his discoveries, all the while battling nagging wives, drunken roommates and stupid bureaucracy. Dr. Martin Clutton-Brock
- 15:00 ConCourse 2G805 **Autograph Sessions** Jean-Louis Trudel Gene Wolfe
- 15:00 MR 1 2G342 **Pern Trivia/Hosting** The Pern Trivia contest will be run as a combination of Jeopardy and Trivial Pursuit. There will be 4 groups of 3, the winner being the group with the highest score in 4 games. Categories include: Pern heraldry, Weyrs, Holds, Crafts, Food & People. Magi Shepley
- 15:00 MR 2 2G459 **Babylon Five Panel** The action, the characters, the special effects. Is it television SF's "last, best hope"? Gerri Bailor Franklin Hummel Perrienne Lurie
- 15:00 MR 4 2G033 **World Building** Haven't we all read stories where the writer got so involved in building the world that they lost the story? Roger MacBride Allen David Drake Dave Duncan Larry Niven Harry C Stubbs Jack L Chalker
- 15:00 MR 6 2G780 **The Archeology of Slasher Films** A discussion of the significance of horror movies in our society. Dr. Carl Matheson
- 15:00 MR 7 2G687 **Magic Meets Technology** Technobabble Vs. Fairy Woo-Woo. Whose wand is stronger? Claire Eddy Glenn Battis Robert Charrette Daniel Fresnot Janice M Eisen Mark Shepherd
- 15:00 MR 9 2G148 **Soviet Space Disasters** A discussion of Russian space technology and political concerns. Jordin Kare Jonathan V. Post Hugh Gregory Andre Lieven
- 15:00 MR10 2G024 **How to Form a Writer's Group** So you have decided to publically declare your insanity and become a writer. How do you find similar souls and how can they help your dream? M Shayne Bell Cynthia Felice Sally McBride ~~Marian Hughes~~
- 15:00 MR13 2G728 **Bantam Books Presents** A slideshow and panel presentation which will preview science fiction and fantasy publications coming from Bantam Spectra Books over the next several

- months, presented by the staff of Spectra. Color slides will feature artwork from upcoming titles. Jennifer Hershey Tom Dupree Janna Silverstein Christian Waters
- 15:00 MR14 2G713 **Winnipeg Doctor Who/Blake's 7 Fan Club** (Tardis 204). Club Meeting Anna Boudreau
- 15:00 MR15 2G875 **Reading by Connie Willis** Connie Willis reads her own work. Connie Willis
- 16:00 ConCourse 2H806 **Autograph Sessions** Anne McCaffrey (members A-L only. 2 books) Kevin J Anderson Peter Nicholls
- 16:00 MR 1 2H049 **To Be a Female Writer** The "glass ceiling" - alive and well in SF&F. Stephanie Bedwell-Grime Myra Cakan Nancy Kilpatrick Elizabeth Moon Carrie Richerson Elisabeth Vonarburg
- 16:00 MR 2 2H677 **Can Technology Help Us Save/Manage Our World** Have we as a people matured fast enough to keep pace with technology, or are we just playing God? Gail S Abend Leslie Gadallah Bart Kemper Bradford Lyau Daniel L Marcus
- 16:00 MR 4 2H331 **The Use of Science in Fantasy** If a sufficiently advanced science could appear as magic, couldn't magic also appear as science? Alexis A Gilliland Betsy Mitchell Geoff Ryman Dr. William Sarjeant Robert Silverberg
- 16:00 MR 5 2H833 **KaffeeKlatsch** Limited ADVANCE Registration - Inquire at Con Info Desk. Joe Haldeman P C Hodgell Barry B Longyear Jody Lynn Nye ~~Charles C Ryan~~
- 16:00 MR 6 2H785 **"IMP's" Meeting** Writers Group Meeting Louise Rowder
- ~~16:00 MR 7 2H070 Reading by Kristine Kathryn Rusch~~ Kristine Kathryn Rusch reads her own work. Kristine Kathryn Rusch
- 16:00 MR 9 2H227 **Designing Diseases** A discussion of disease and how it works to help you in your world. Shariann Lewitt Jeri Freedman Ian K Hagemann Judy Lazar Perrienne Lurie J.D. Maynard
- 16:00 MR10 2H144 **How to Edit** How to read like an editor. Ginjer Buchanan Ellen Dattow Scott Edelman Josepha Sherman Janna Silverstein Shawna McCarthy
- 16:00 MR12 2H732 **What is Magic, the Game?** Learn about the new game that's taking over gaming tables everywhere. Susan Mohn
- 16:00 MR13 2H011 **Musing with Mouse (tm)—Applications of Virtual Reality** Mouse (tm)—Multidimensional User-oriented Synthetic Environment—is a unique new Virtual Reality shell invented by Dr. Creve Maples and Craig Peterson of Sandia National Laboratories in New Mexico. Dr. Andrews has worked with inventors to apply VR principles to practical engineering problems for industry. Dr. Arlan Andrews
- 16:00 MR15 2H235 **OnLine Communities** What do you think like is like in a virtual community? Can you still have safe sex in a virtual relationship? Alexandra Honigsberg Marty Helgesen Ken Meltzner Terry O'Brien Henry Spencer
- 17:00 Concourse 2I807 **Autograph Sessions** Jeanne Robinson Spider Robinson Robert J. Sawyer
- 17:00 MR 1 2I352 **What to do When Universal Translator Breaks Down** The problems of communication between completely different cultures. Timothy L Smith Gail S Abend Roger Burton-West Greg Costikyan Kate Soley
- 17:00 MR 2 2I563 **Is Modern SF A Reactionary Literature?** Is SF currently reactionary against mainstream literary ideas, against "society's" ideas, or against itself? Peter Nicholls Daniel Fresnot Dr. Elizabeth Anne Hull J.R. Dunn Martha Soukup
- 17:00 MR 7 2I688 **Christian Fandom Meeting** Cristian fandom meeting. General discussion of science fiction in relationship to Christianity. Primary interest to Christian fans but all are welcome. Marty Helgesen Ross Pavlac G. F. Proechel Kathy Tyers
- 17:00 MR 8 2I877 **Reading by S. M. Stirling** S. M. Stirling reads own work. S. M. Stirling
- 17:00 MR 9 2I541 **Being a Pagan in Professional Society** What defines "pagan" in today's society? Does admitting to such hurt one's ability to deal with certain segments of society? How can you deal with it? Julia Martin Sue-Ryn Hildenbrand-Burns

- 17:00 MR10 2I773 **Introduction to Play-by-Mail Gaming** Play-by-Mail Gaming originated in the early 1800's. Learn why it is one of the fastest-growing segments of gaming today. A brief history of PBM will be presented, as well as an introduction into modern PBM game systems. Specific questions on the "Legends" PBM game system will be addressed. Simon Parkinson
- 17:00 MR12 2I736 **Bheer Home-Brewing** Home-brewing bheer with demo and samples from Canadian home-brewing supply house. Brewers Direct William "Wolf" Foss Rick Foss George Flentke Lise Otto
- 17:00 MR13 2I723 **So What's A Science Fiction 'Garage' Kit?** Slide show introduction to the field of resin, vinyl and plastic figure kits. Stan Hyde
- 17:00 MR14 2I044 **Balancing Writing With Family** Little Sally has a dance recital, Billy has a soccer game, the Baby is teething, my Protagonist faces death, and I haven't made love to my Spouse in two weeks - Who wins? Mary H Rosenblum Laura Frankos William R. Lund Sandra Morrese Ann Tonsor Zeddies
- 17:00 MR15 2I764 **Books through the Internet** BiblioBytes started selling and distributing books via the Internet in July, 1994. Their publications includes books by Barry B. Longyear, Nancy Kress, Spider Pobinson, Parke Godwin, Octavia E. Butler, Ron Goulart, John Belancourt and Harlan Ellison. Glenn Hauman
- ~~19:00 MR 2 2J787 The Gathering - A Pernese-style gathering in honour of Anne McCaffrey. Preregistration is required at the Living Fiction's tent table. Dee McLoughlin~~
- 19:00 MR 6 2K770 **Jewish Sabbath Services** Traditional Orthodox service for all wishing to attend. Head coverings required for male attendees.
- 19:30 MR 2EFG **The Gather** In honour of guest-of-honour Anne McCaffrey, we are presenting a Pernese Gather with dragon decorations and a variety of performer's and dancers in proper Pernese tradition. Pernese refreshments will be served to guests. There will be prizes awarded in various categories relevant to the evening - so dress in your finest costumes.
- 20:00 MR 7 2L629 **Electronic Publishing** What is the future of SF in the electronic age? Ginjer Buchanan Glenn Hauman Greg Costikyan Shelly Shapiro ~~Maeve Feder Kathryn Cramer~~
- 20:00 MR13 2L195 **Getting Off the Rock** There's more than one way to get there! Alternative methods of space launch. Jordin Kare
- 20:30 MR 1 2L674 **Regency Dance** John teaches English Regency ballroom dance (circa 1800). Come in costume or as you are. John Hertz
- 21:00 MR 2 2M783 **Ahead warp speed with the Standard Orbit Players** and their Star Trek presentation. It's funny, it's irreverent; it will make Spock blush to the tips of his pointed ears. Lance Sibley
- 21:00 MR 7 2M250 **What Should Have Made it on the Hugo Ballot, But Didn't** A moderated group discussion of what (or who) should have, but didn't make it onto this year's Hugo ballot. Joseph T Mayhew
- 21:00 MR12 2M622 **Trends in Horror** How is the horror story changing in today's world? Kathryn Cramer Dawn Dunn Mary A Turzillo Dale Sproule
- 21:00 MR13 2M722 **How to Design Credible Aliens** Dr. Cohen works with SF authors, including Anne McCaffrey. Jack Cohen
- 22:00 MR 7 2N604 **Pictionary: Artists Vrs Authors** Watch them sweat against the clock. Who is better at placing words to a picture? Geoff Ryman Rebecca Moesta Anderson Phill Foglio Kaja Foglio John M. Landsberg
- 22:00 MR13 2N243 **Bad Movies** We've all seen them. We've really loved some of them. Why are some bad movies just so darn good? Stan Hyde Michael Skeet Ric Meyers
- 23:00 MR 7 2O088 **PC/Multiculturalism and its Influence on SF** Can you be politically correct and still like SF? J.R. Dunn Clifton Amsbury Ian K Hagemann Astrid Julian Ron Sarti
- 23:00 MR 12 2O632 **Vampires: Fact, Fiction, and Myth** Vampire stories have been around for as long as acne. How did they begin, how have they changed, and can they still be living among us? Lee Barwood Stephanie Bedwell-Grime Joshua Bilmes Daniel Dvorkin Alexandra Honigsberg
- 24:00 MR 7 2P00 **Midnight Horror Readings** Readings open to at-con sign-up. Scott Welch Nancy Lilpatrick ~~Ed Bryant Forrest Jackerman~~
- 24:00 MR13 2P091 **Alternative Music** Every generation believes it has found something new. How can you tell when it is out? Pras Stillman Daniel Duorkin Jordin Kare

TIME	MEETING ROOM 1	MEETING ROOM 2	MEETING ROOM 4	MEETING ROOM 5	MEETING ROOM 6	MEETING ROOM 7	MEETING ROOM 8	MEETING ROOM 9	MEETING ROOM 10	MEETING ROOM 12	MEETING ROOM 13	MEETING ROOM 14	MEETING ROOM 15	MEETING ROOM 16	CAMP SOUTH	OTHER LOCATIONS	TIME
9:00					Jewish Sabbath Services		Aerobics										9:00 AM
10:00	What is Upcoming with WOTC & Magic		Highlander: The Series and the Movie	KaffeeKatsch		Reading by Josepha Sherman			Model Contest, Second Session	Running SF Clubs/Libraries	Reviewing/Criticism		"Behind-the-Scenes" of Publishing & Sales			SFRA Breakfast - Place Louis Riel	10:00 AM
11:00	Ozone Hole	Alternate Canadas			Cryonics	National Library of Canada exhibit				How to Survive & Enjoy An SF Convention	Reading by Joe Haldeman		SF Jeopardy!	Folk Music SF/F			11:00 AM
12:00	ANSFS Business Meeting, First Session	Shared World Fiction		KaffeeKatsch	<i>Putting On a Con</i>	Reading by Guy Gavriel Kay		Folk Music in SF/F	Nuts and Bolts of Game Publishing	Fandom In Russia	Enduring Myths (Robin Hood, King Arthur)	<i>Reading by M. Shayne Bell</i>					12:00 PM
13:00		Interview of George Barr by Karen Haber	Canadian Astronaut Talk and Autographs		<i>What Judges Look For at Masquerades</i>		Shotokan Karate Workshop	Reading by Mike Resnick	<i>Fat, Masculinity, & Fandom</i>	Journey of the Hero	Russian Interplanetary Probes	Reading by Charles Sheffield	Short Fiction Vs. Longer Fiction Forms	Filk Samplers	SF Films	Convention Meeting, SF Canada - Library	1:00 PM
14:00	Humor in our Genre	Celtic Mythology		KaffeeKatsch		Electronic Fandom		How to Do Costuming (Costuming 101)	Reading by Geoff Ryman	Aspects of Future History	Fandom & Convention in Japan		12 noon - 4pm	Workshop, Harmony singing	SF Canada Business Meeting - Library	2:00 PM	
15:00	Golden Duck Awards	Dinosaurs in SF			<i>Masquerades is a theatrical Venue</i>	Putting a Zine Together		The Value of Regular Writer's Groups	Reading by George R. R. Martin	Women in Combat	The Alien Face		Bioethics / Bioengineering	Workshop, Song writing	Aurora Awards - Library	3:00 PM	
16:00	Chesley Awards	Psi Powers	Upcoming Movies Presentation	KaffeeKatsch	Internet - New Apps & Directions	First Fandom Annual Meeting		Techniques in Acrylic Painting	Q&A with Jean Lorrain	Genetic Engineering	Other Cultures in F&SF (Cultural Heritage)	Research for Science Fiction Writers/Lecture	Editing Magazines & Anthologies	Concert Lynn Gold Joey Shoj	Panel, Filk fandom		4:00 PM
17:00		Post-Cyberpunk			The Many Faces of Fandom			How to Stay Alive 'Til You Big Break	Towards a Language of Critical Games Analysis	Utopia: Who Wants to Live There?	The Art of ON SPEC	Reading by Elisabeth Vonarburg	Why "Manned" Space Flight?	Concert Dandelion Wine			5:00 PM
18:00													Artemis Project Introduction				6:00 PM
19:00																	7:00 PM
20:00												Jam, Parody / Humor 8:30 - 10:30	Workshop, Performance Anxiety 8:30 - 10:30	One shots, Filk performances 8:30		HUGO Awards - HALL "B"	8:00 PM
21:00							ConFURance	How to Manhandle your Friends						Workshop, Unfinished songs 8:30			9:00 PM
22:00	The End of the World	Ghosts										Open Filking 10:30....	Open Filking 10:30....	Open Filking 10:30....		ROCK DANCE - 10:30 Start RM2EFG	10:00 PM
23:00																	11:00 PM
24:00																	12:00 AM

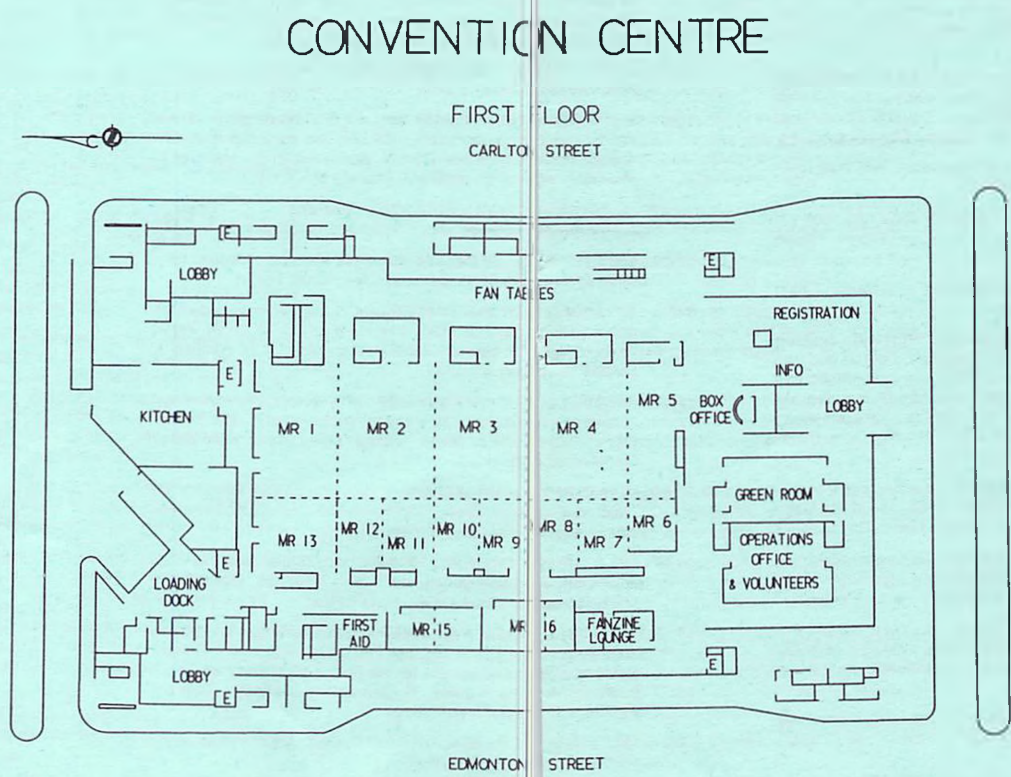
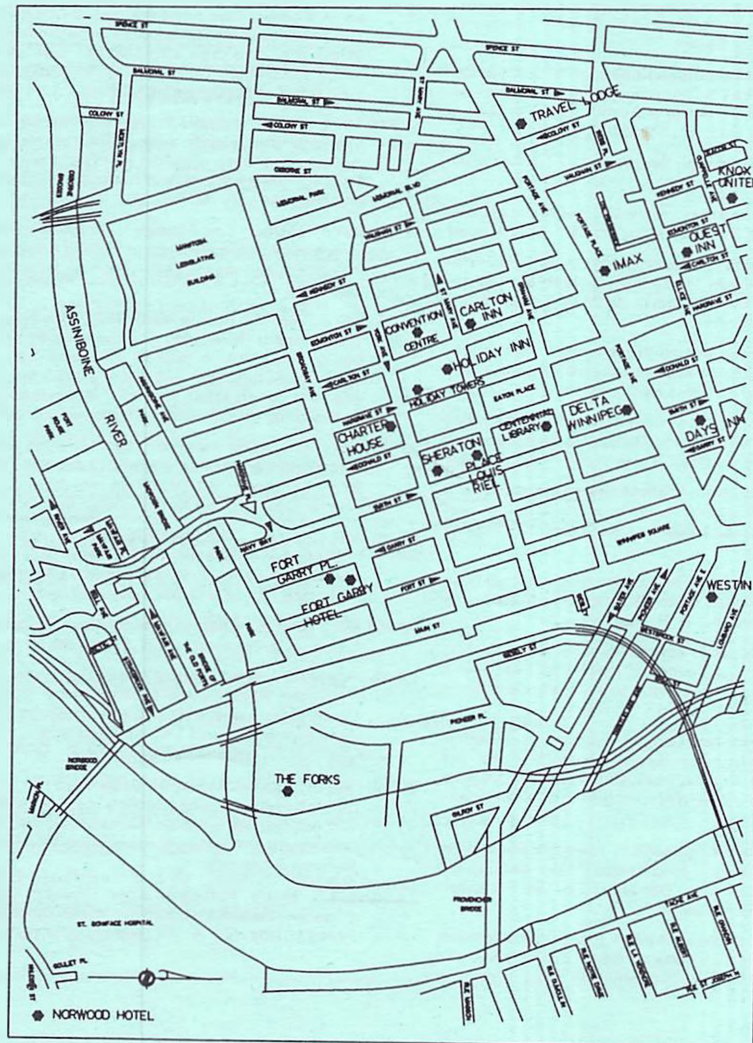

SECOND FLOOR

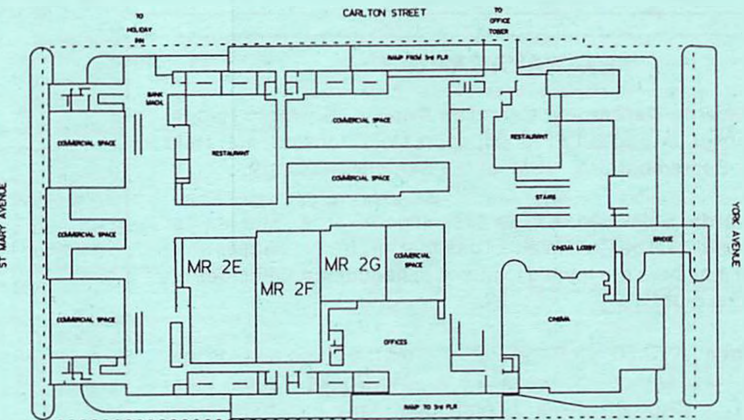

THIRD FLOOR

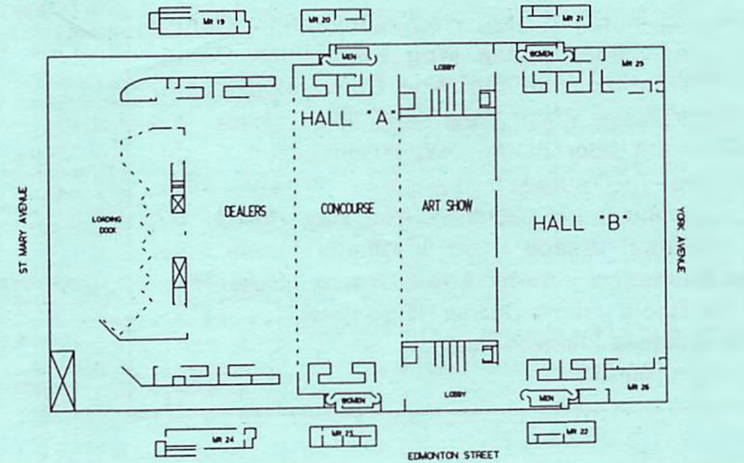

FILK PROGRAM SCHEDULE

- 11:00-12:00 MR16 Panel, Folk Music in SF/F Joey Shoji, Mary Ellen Wessels, Elizabeth Ann Scarborough Which authors draw heavily on folk music in their writing? How is folk music relevant to SF/F?
- 12:00-04:00 MR16 Filk Sampler 15 minute filk teasers
- 02:00-03:00 CAMP-S Workshop, Harmony singing Lynn Gold, Joey Shoji, Jodi Krangle, Cheryl Miki Just how do you get those awesome sounds?
- 03:00-04:00 CAMP-S Panel, Taking filk beyond the con Kathy Mar, Graham Leathers, Joey Shoji, Dave Clement So what do you do with all of this great music when there are no cons going on? Can/does filk survive in the mainstream (or a side stream)?
- 04:00-05:00 CAMP-S Workshop, Song Writing - advanced Kathy Mar, Pete Grubbs, Nate Bucklin For those who are already writing songs, some tips from some of the finest song writers around.
- 04:00-04:30 MR16 Concert, Lynn Gold
- 04:30-05:00 MR16 Concert, Joey Shoji
- 05:00-06:00 CAMP-S Panel, Filk fandom Roberta Rogow, Stephanie Bedwell-Grime, Judith Hayman, David Hayman, Kathleen Sloan, Glenn Simser So what is this filk fandom I keep hearing about?
- 05:00-06:00 MR16 Concert, Dandelion Wine
- 08:30-10:30 MR14 Jam, Parody/humour Roberta Rogow, Kathy Mar, Pete Grubbs, Graham Leathers, Brett Glass
- 08:30-10:30 MR16 Workshop, Performance Anxiety w/ Mary Ellen Wessels sign up in Filk Lounge
- 08:30-09:30 MR15 One shots, filk performances sign-up in Filk Lounge
- 09:30-10:30 MR15 Workshop, Unfinished Songs sign up in Filk Lounge
- 10:30—> MR14 Open filking
- 10:30—> MR16 Open filking
- 10:30—> MR15 Open filking

EXTRAVAGANZAS

Aurora Awards Ceremony Canadian Awards, similar to Hugos, for best novel in English / French, short story, fanzine, etc. Held Saturday, September 3rd, 3PM at the Centennial Library.

Hugo Awards 8 pm Hall B The 41st Hugo Awards The Master of Ceremonies will be ConAdian's Toastmaster, Barry Longyear. All ConAdian members are invited to attend to honour the Nominees on their special night.

Rock Dance 10:30 pm Rm2EFG After the Hugo awards join us at the Rock Dance sponsored by Warner Books. Come meet authors, C.J. Cherryh, Kevin J. Anderson, Jane Fancher, David Feintuch and others....they'll give away prizes, free books and more!

PROGRAM ROOM LOCATIONS

- HALL "B"** - 3rd floor of the Wpg Convention Center
- MR 2EFG** - 2nd floor of the Wpg Convention Center
- MR 1 thru 15** - 1st floor of the Wpg Convention Center
- WEST** - Westminister Room West 2nd floor Holiday Inn
- Concourse** - 3th floor of the Wpg Convention Center
- Con Cont Loop** - WCC outside main entrance 1st floor
- CAMP-S** - Campaign rm "South" 2nd floor Holiday Inn
- Science Channel Videos** - 3rd flr Charter House Hotel
- Japanese Animation** - Lower Level Charter House Hotel
- British Video Room** - 5rd flr Charter House Hotel
- Writers Workshops** - Sheraton Hotel
- Gaming** - Place Louis Reil

SATURDAY PROGRAM SCHEDULE

- 09:00 MR 6 3A771 Jewish Sabbath Services Will read from the bible in hebrew and have a public prayer. Need at least 10 men for the service, especially welcome those who can read hebrew.
- 09:00 MR 8 3A746 **Aerobics** John Douglass
- 10:00 Concourse 3B808 **Autograph Sessions** Anne McCaffrey (members M-Z only, 2 book limit) Richard Knaak Len Wein
- 10:00 MR 1 3B733 **What Is Upcoming with WOTC & Magic** What's next from the people who developed "Magic" Susan Mohr
- 11:00 MR 4 3C726 **Highlander: The Series and the Movie** The staff of the Los Angeles office of Highlander: The Series takes you through the process of creating an episode from concept to screen. Also: A preview of the upcoming Highlander III movie, and tidbits on the new season of the series. Q & A follows. Gillian Horvath Donna Lettow
- 10:00 MR 5 3B834 **KaffeeKlatsch** Limited ADVANCE Registration - Inquire at Con Info Desk. Roger MacBride Allen Ginjer Buchanan Edward Kramer Elizabeth Moon Jean-Louis Trudel
- 10:00 MR 7 3B878 **Reading by Josepha Sherman** Josepha Sherman reads her own work Josepha Sherman
- 10:00 MR10 3B730 **Model Contest, Second Session** Models on display in the Art Show. Sheila Adler Barry Adler
- 10:00 MR12 3B093 **Running SF Clubs/Libraries** So you want to share your personal love. Here are some tips on starting and maintaining a successful club. Michael Wallis Jill Eastlake Robert Runte Henry Welch Fred Patten D.J. Stein
- 10:00 MR13 3B193 **Reviewing/Criticism** What is the difference between a reviewer and a critic? How can you be a successful one? ~~Dean Wesley Smith~~ Rick Foss Ashley D Grayson Paula Johanson ~~Kristine Kathryn Rusch~~ Janeen Webb Tom Whitmore
- 10:00 MR15 3B224 **Behind-the-Scenes of Publishing & Sales** Can artistic and editorial creativity survive in a business driven by sales? Susan Allison Ian Ballantine Betty Ballantine Tom Doherty Kuo-Yu Liang David Wixon
- 10:00 Place Louis Reil 3B768 **SFRA Breakfast** Held in Diane Miller's suite at the Place Louis Reil. Diane Miller
- 11:00 ConCourse 3C809 **Autograph Sessions** M Shayne Bell Scott Edelman Fredrick Pohl ~~Dave Wolverton~~ ~~David Doering~~
- 11:00 MR 1 3C062 **Ozone Hole** Is it real or just a hoax by Big Business to force a costly conversion to a new product? Timothy Lane Keith G. Kato Ctein Leslie Gadallah Karl Johanson
- 11:00 MR 2 3C222 **Alternate Canadas** As Canada moves from crisis to crisis, can stability come from merging with the U.S.? Robert Sawyer Glenn Grant Evelyn Leeper Andre Lieven Deryll Murphy David Nickle
- 11:00 MR 6 3C037 **Cryonics: Time-Capsule to the future?** Is freezing a way to get to the future? What would it be like for the reanimates? Presentation by the Cryonics Society of Canada. Ben Best
- 11:00 MR 7 3C000 **1995 National Library of Canada SF & Fantasy exhibit.** Presentation of the upcoming exhibit at the National Library in Ottawa, with a side exhibit at The Merril Collection. Allan Weiss
- 11:00 MR12 3C163 **How to Survive & Enjoy An SF Convention** Or...Can I really survive on stale popcorn and flat Diet Coke for four days? Gay Haldeman Gerri Balter David W Clark David Hayman George (Lan) Laskowski ~~David Rogow~~ ~~Robert Rogow~~
- 11:00 MR13 3C879 **Reading by Joe Haldeman** Joe Haldeman reads his own work. Joe Haldeman
- 11:00 MR15 3C762 **SF Jeopardy!** What TV show has been set up for fans at ConAdian. Teams of three to compete. Doug Kemp
- 12:00 ConCourse 3D810 **Autograph Sessions** Shariann Lewitt Harry Turtledove Carrie Richerson
- 12:00 MR 1 3D720 **WSFS Business Meeting, First Main Session** Today, amendments to the WSFS Constitution will be debated and voted on. Also, reports from Worldcon committees and the elections to the WSFS Mark Protection Committee are expected. If you are a member of ConAdian, you are a member of WSFS and are welcome to attend this meeting and participate in the debate. Kevin Standlee
- 12:00 MR 2 3D048 **Shared World Fiction** I created this world — How dare you blow it up with nukes! George R R Martin Joshua Bilmes Robert Charrette Peter J Heck Sasha Miller
- 12:00 MR 4 3D106 **Books that Changed my Life** An introspective look into a first love that turned into a life-long obsession. Marjii Eilers Joel Champetier Anne McCaffrey Alan Stewart ~~Mark Anthony~~
- 12:00 MR 5 3D835 **KaffeeKlatsch** Limited ADVANCE Registration - Inquire at Con Info Desk. Greg Costikyan William "Wolf" Foss David G Hartwell Patrick Nielsen Hayden Bridget McKenna
- 12:00 MR 7 3D880 **Reading by Guy Gavriel Kay** Guy Gavriel Kay reads his own work Guy Gavriel Kay
- 12:00 MR 9 3D332 **Folk Music in SF/F** Can or should the folk ballad be used for fantasy stories? Has this ever been done successfully? What is the role of folk music in the future of mankind? Elizabeth Ann Scarborough ~~W.A.S. Sargent~~
- 12:00 MR10 3D631 **Nuts and Bolts of Game Publishing** The how-to guide to help you break into the industry. Roger E. Moore Julia Martin Sue Weinklein
- 12:00 MR12 3D451 **Fandom in Russia** This event will be devoted to our history and current situation in our fandom, and not only in Russia but all C.I.S.'s. Yuri Savtchenko
- 12:00 MR13 3D617 **Enduring Myths (Robin Hood, King Arthur, others)** Who do some stories continue to live on when others die so young? Jean Lorrach Ann L. Chancellor Mary Cannings Terry O'Brien Lorna Toolis
- 13:00 ConCourse E811 **Autograph Sessions** Roger MacBride Allen Dave Wolverton Elisabeth Vonarburg
- 13:00 Library 3E166 **Convention Meeting, SF Canada Meeting** The Canadian Science Fiction and Fantasy Association, a non-incorporated, non-profit body, will hold its annual business meeting and decide upon the site of the next Convention. Open to all Convention members (i.e. ConAdian members who are either Canadian citizens or permanent residents, or paid-up Convention members.) Jean-Louis Trudel
- 13:00 CAMP-S 3E198 **SF Films** A discussion of SF from Hollywood: The good, the bad, and the cyberpunk. Steve Fahnestalk Myra Cakan John M. Landsberg Mark Leeper Craig Miller Michael Skeet
- 13:00 MR 2 3E724 **Interview of George Barr by Karen Haber** Karen Haber (Silverberg) is an experienced artist interviewer. Karen Haber George Barr
- 13:00 MR 4 3E731 **Canadian Astronaut Talk and Autographs** Marc Garneau, the first Canadian Astronaut to rocket into space talks about his personal experiences in space. He will also describe the specialized astronaut training he is currently undergoing at NASA. Marc Garneau
- 13:00 MR 8 3E193 **Shotokan Karate Workshop** Con-goers (12 years and older) are invited to participate in a one-time training session in the dynamic martial art of Skotokan karate. This session will be non-strenuous and safe, concentrating on basic karate mechanics. Participants should wear loose clothing Keith G. Kato
- 13:00 MR 9 3E881 **Reading by Mike Resnick** Mike Resnick reads his own work Mike Resnick
- 13:00 MR 10 3E193 **Shotokan Karate Workshop** Con-goers (12 years and older) are invited to participate in a one-time training session in the dynamic martial art of Skotokan karate. This session will be non-strenuous and safe, concentrating on basic karate mechanics. Participants should wear loose clothing Keith G. Kato
- 13:00 MR12 3E24 **Journey of the Hero** What should the Hero's journey mean to us? Can we identify with the journey? Lee Farwood David Drake Janeen Webb K. D. Wentworth Ann Tonsor Zeddies Jack L Chalker
- 13:00 MR13 3E149 **Russian Interplanetary Probes** A look back across 30 years of Soviet Interplanetary exploration, in particular the probes for Venus and Mars made by the Lavochkin Association. Photos of the actual engineering models that were used to test and work out problems on the spacecraft before they were launched and while in flight. Hugh Gregory
- 13:00 MR14 3E184 **Reading by Charles Sheffield** Charles Sheffield reads his own work Charles Sheffield
- 13:00 MR15 3E05: **Short Fiction Vs. Longer Fiction Forms** Short fiction, novels, and novels. It's only the word count, right? Sandra Morrissette Gardner Dozois Nancy Kilpatrick Maureen F McHugh Mary H Rosenblum Shawna McCarthy
- 14:00 ConCourse 3F812 **Autograph Sessions** C J Cherryh ~~Kristine Kathryn Rusch~~ Mark Shepherd ~~Stanley Schmidt~~
- 14:00 Library 3F73 **SF Canada Business Meeting** Meeting only open to members of SF Canada. Jean-Louis Trudel
- 14:00 MR 1 3F261 **Humor in our Genre** Laughter is an important part of living. Why don't we see more of it in SF? Dr. Arlan Andrews Susan Casper Janet Hetherington K. D. Wentworth Connie Willis
- 14:00 MR 2 3F21 **Celtic Mythology** Why does Celtic mythology survive and thrive when so many others have not? Guy Gavriel Kay Roge Burton-West Josepha Sherman Kate Soley Lindalee Stuckey
- 14:00 MR 5 3F83E **KaffeeKlatsch** Limited ADVANCE Registration - Inquire at Con Info Desk. Cynthia Felice Jack L Chalker Jack Dann Marthi Soukup Michael Whelan
- 14:00 MR 7 3F17E **Electronic Fandom** What's the on-line fannish community a how do you join? Ken Meltsner Glenn Battis Marty Helgeson Saul Jaffe Maia Cowan
- 14:00 MR 9 3F137 **How to Do Costuming (Costuming 101)** So you want to get into costuming, but you don't know where to start. Some tips and suggestions for the novice from those who have been there. Marjii Eilers Stephanie Ann Johanson Pierre E Pettinger Jr. Sandra G Pettinger
- 14:00 MR10 3F88 **Reading by Geoff Ryman** Geoff Ryman reads his own work Geoff Ryman
- 14:00 MR12 3F209 **Economic/Political Aspects of Future History** Are we moving toward a global economy or just re-entering the Dark Ages? Philip Kaveny Briccio Barrientos M Shayne Bell David Hayman Timothy Lane
- 14:00 MR13 3F346 **Fandom & Convention in Japan** SF and fan activity in Japan. A view of Japan's 33rd national convention held on Olinawa Island. Takumi Shibano Masamichi Osako Ken Yamaoka ~~Anthony Bryant~~ ~~Yasuo Kawai~~
- 15:00 ConCourse 3G813 **Autograph Sessions** Robert Silverberg Karen Haber Gregory Bennett
- 15:00 Library 3G744 **Aurora Awards** Canadian Awards, similar to Hugos, for best novel in English / French, short story, fanzine, etc. Jean-Louis Trudel
- 15:00 MR 1 3G378 **Golden Duck Awards** The Golden Duck Award is for excellence in children's SF. Come and hear about the best of children's science fiction today and see slides of science fiction picture books. These awards are sponsored by Duckon, a science fiction convention near Chicago. Presenters: Lindalee Stuckey, Trudi Puda, Helen Gbala, Douglas Drummond. Lindalee Stuckey
- 15:00 MR 2 3G328 **Dinosaurs in SF** An exploration of the recent glut of dinosaurs after being extinct for 65 million years. Ric Meyers Richard Chwedyk Stephen Dedman Stan Hyde Hayford Peirce Beth Meacham
- 15:00 MR 7 3G190 **Putting a Zine Together** Tips on starting and improving your 'zine. George (Lan) Laskowski Cindy Huckle Timothy Lane Magi Shepley Henry Welch Andrew Porter
- 15:00 MR 9 3G031 **The Value of Regular Writer's Groups** So you have found a group you like, but are they really helping you? Isn't writing supposed to be a "solitary" pursuit? Anthony Bryant Janice M Eisen Adrienne Foster Astrid Julian Geoffrey A Landis Michael Skeet
- 15:00 MR10 3G883 **Reading by George R. R. Martin** George R. R. Martin reads his own work. George R R Martin
- 15:00 MR12 3G272 **Women in Combat** Let's face it, women can be nastier than men. Does sex really make a difference? Jan Howard Finder Daniel Dvorkin Bart Kemper Elizabeth Moon Perry Williams
- 15:00 MR13 3G760 **The Alien Face** What do we read as an alien? It seems we can best be spooked by what we recognize in terms of our knowledge of the human face. The SF artist can exploit that knowledge. Heather Spears
- 15:00 MR15 3G697 **Bioethics/Bioengineering** If science can change a species, how can we protect ourselves? Who will decide who gets to benefit? Susan M Smith Ctein L Warren Douglas Kathleen Ann Goonan Norman Hartman
- 16:00 ConCourse 3H814 **Autograph Sessions** Greg Costikyan Leslie Gadallah Barry B Longyear
- 16:00 MR 1 3H745 **Chesley Awards** Reception and awards hosted by ASFA. Artist awards for artwork and artists. Stu Hellingner
- 16:00 MR 2 3H281 **Psi Powers** A discussion on the various psi powers: what they are and how to use them. David M. Kushner Joyce Andrews Glenn Battis Norman Hartman Elizabeth Ann Scarborough Anne McCaffrey
- 16:00 MR 4 3H734 **Upcoming Movies Presentation** Movies may include Judge Dredd, Shelly's Frankenstein and Interview With The Vampire Len Wein Charles Lippincott
- 16:00 MR 5 3H837 **KaffeeKlatsch** Limited ADVANCE Registration - Inquire at Con Info Desk. Terry Garey Jeanne Robinson Spider Robinson Harry C Stubbs Gene Wolfe M Shayne Bell
- 16:00 MR 6 3H061 **Internet—New Applications & Directions** Is it real or is it InterNet? What else can be done online? Ben Best Glenn Hauman ~~Jack C Haldeman Jr~~ Matt Crawford Ellen Key Harris
- 16:00 MR 7 3H609 **First Fandom Annual Meeting** Annual business meeting, open to all Conadian members, followed by application for membership. D. H. Blair
- 16:00 MR 9 3H238 **Techniques in Acrylic Painting** Brush strokes, colours, tools... all the tips needed to make your own work a piece of art. Focus on textures... How to make a brick look like a brick. Enn McKee
- 16:00 MR10 3H226 **Q&A with Jean Lorrach** This is the usual Lorrach/Lichtenburg presentation but Jacqueline can't attend this year. Jean will have info on both authors latest projects including Savage Empire, Sime/Gen and Star Trek novels. Jean Lorrach
- 16:00 MR12 3H168 **Genetic Engineering** If we can re-engineer flowers and vegetables, how long before Ronko markets the "Gene Master?" James Young Daniel Dvorkin Jeri Freedman Ian K Hagemann Susan M Smith
- 16:00 MR13 3H658 **Other Cultures in F&SF** (Cultural Heritage and Myths) How to use another culture's myths in you fiction. S. M. Stirling Sasha Miller K. D. Wentworth Mary Cannings Daniel Fresnot

- 16:00 MR14 3H020 **Research for Science Fiction Writers/Lecture** Why bother with research. Where to start. When to end. Who to talk to. What pitfalls to avoid. How to take notes that really help. The info on how to get info. Billie Aul
- 16:00 MR15 3H066 **Editing Magazines & Anthologies** If you are an editor, what's the difference between magazines and anthologies? How far should an editor go to shape a story? Ellen Datlow Gardner Dozois Scott Edelman David G Hartwell Mike Resnick Charles C Ryan
- 17:00 ConCourse 3I815 **Autograph Sessions** Dawn Dunn Jack Dann ~~Stanley Schmidt~~
- 17:00 MR 2 3I659 **Post-Cyberpunk** Where does the future take us now? Daniel L Marcus Bandit David Brin Maureen F McHugh Allen Steele
- 17:00 MR 6 4I004 **Waiting for the young adult market** Carol Matas Josepha Sherman Lindalee Stuckey
- 17:00 MR 6 3I216 **The Many Faces of Fandom** What are all these people doing? Is it as weird as it looks? Why do they all look alike? Mike Glyer Daniel Fresnot Mike Glicksohn Franklin Hummel George (Lan) Laskowski Alan Stewart
- 17:00 MR 9 3I050 **How to Stay Alive 'Til Your Big Break** Do you really need to eat after you submit your manuscript? Roger MacBride Allen Kevin J Anderson K.B. Bogen David Drake Janet Hetherington
- 17:00 MR10 3I774 **Towards a Language of Critical Games Analysis/Design** What is a good game? How can you tell a good game from a bad one? As game designers, we need a way to analyze games, to try to understand what works and what makes them interesting. And we need to invent a critical language to do this. Greg Costikyan
- 17:00 MR12 3I671 **Utopia: Who Wants to Live There?** The pros and cons of the Utopian society. Dr. Arlan Andrews Dr. Janice Bogstad Donald Kingsbury Frederick Andrew Lerner Jack Nimersheim
- 17:00 MR13 3I109 **The Art of ON SPEC** From the beautiful to the bizarre. Presented by Lynne Fahnestalk, art director of ON SPEC, the award-winning Canadian magazine of speculative writing. Lynne Taylor Fahnestalk
- 17:00 MR14 3I885 **Reading by Elisabeth Vonarburg** Elisabeth Vonarburg reads her own work Elisabeth Vonarburg
- 17:00 MR15 3I775 **Why "Manned" Space Flight?** Much of the confusion and indecision over the space program is because, we as a nation, have never decided WHY we are in space. This panel explores the definition and prioritization of these objectives, and their affect on the type and scope of space activities. SIGN UP by Saturday 12 noon in VIP Lounge of the Convention Centre. John Strickland Jr.
- 18:00 MR 9 3J737 **Artemis Project Commerical Lunar Base** Everyone who wants to work on the Artemis Project commercial lunar base is invited to attend this organizational meeting! Meeting open to all Conadian members. Gregory Bennett
- 21:00 MR 8 3M786 **Con Furence** Artists are invited to perform work at the jam. Fans and aspiring artists are welcome. Pickup tips and maybe commission an art piece. Rodney Stansfield
- 21:00 MR 9 3M113 **How to Manhandle your Friends & Have them Love it (Massage)** Workshop to provide some basic instruction in how to manually manipulate the hands, back, head, face and feet to achieve stress reduction and a nice pleasant feeling. Attendees participate by practicing on each other. Jan Howard Finder
- 20:00 HALL "B" **Hugo Awards** The 41st Hugo Awards The Master of Ceremonies will be ConAdian's Toastmaster, Barry Longyear. All ConAdian members are invited to attend to honour the Nominees on their special night.
- 22:00 MR 1 3N273 **The End of the World** Every society has their legends of how the world will end. But what happens afterwards? Mary A Turzillo Sandra Morrissette Charles Pellegrino Connie Willis Terry J. Jones
- 22:00 MR 2 3N135 **Ghosts** A discussion of ghosts in fact and fiction. Lee Barwood P. N. Elrod Jim Groat
- 22:30 RM2EFG **Rock Dance** After the Hugo awards join us at the Rock Dance sponsored by Warner Books. Come meet authors, C.J. Cherryh, Kevin J. Anderson, Jane Fancher, David Feintuch and others....they'll give away prizes, free books and more!
- 23:00 MR12 3O310 **Vampire Book Tour** A bloodcurdling tour of vampire books lurking on bookstore shelves. Will concentrate more on the newer fiction, but will also discuss with the audience some not-to-be-missed classics. Beverley Richardson
- 18:00 MR 5 3P189 **Putting on a con** The do's and don'ts from those who have already built the wheel David Hayman Bill Farwa Cindy Huckle Val Ontell Henry Welsh Tom Veal

TIME	MEETING ROOM 1	MEETING ROOM 2	MEETING ROOM 4	MEETING ROOM 5	MEETING ROOM 6	MEETING ROOM 7	MEETING ROOM 8	MEETING ROOM 9	MEETING ROOM 10	MEETING ROOM 12	MEETING ROOM 13	MEETING ROOM 14	MEETING ROOM 15	MEETING ROOM 16	CAMP SOUTH	OTHER LOCATIONS	TIME	
9:00							Aerobics										9:00 AM	
10:00	How to get Artwork Published, Artists Going Pro	Magic Realism	Military SF	KaffeeKatsch		Publishing on the Desktop		Advances in Medicine, Genetics, Technology, Etc		SFWA Meeting	Electronic Fiction & Publishing					Pagan Ritual - 10:30 Fort Rouge Park	10:00 AM	
11:00	Future of Space Exploration	Use of Violence in SF	Writing with Anne McCaffrey			Cyberspace in multi-use dungeons		Biethics Considerations					How to Sell SF to General Readers as Literature	Workshop, Performance Skills	Pegasus Awards		11:00 AM	
12:00	WSFS Business Meeting, Second Main Session	The Meaning of Dark Fantasy	Star Wars Novels	KaffeeKatsch		Reach for the Stars/Trivia Contest with Star Trek Regina		What is REALLY Killing the Backlist of Good Bks	Getting Your Stars Right the First Time		The DreamTime Art of the Australian Aborigines	Reading by Harry Stubbs (Hal Clement)	One Language for the World?	Songs from the worlds of Anne McCaffrey			12:00 PM	
13:00		How We Deal With Death & Dying	Liar's Panel on How to Get Published		GnuGnome/Gnome Press Presentation			The Library of the World at Your Desk	Reading by Jack L. Chalker	Dragonriders of Pern Fan Clubs	The Kinging Empire on 5 Credits A Day!	Non-Monogamous or Non-Heterosexual Relationships					1:00 PM	
14:00	Themes of Abuse	Gender Roles	The State of SF TV/Movies	KaffeeKatsch		Aliens in the 90's	Breaking into the Professional Markets	Future of Education	Importance/Ethics of Terraforming Other Planets	SF Vs. Fantasy	Breaking into Screenwriting		Reading by Jean-Louis Trudel	Instant Band Showcase			2:00 PM	
15:00	Does our Culture Have a Myth System?	Let's Drive A Stake Through The Romantic Vampire	SF and Social Responsibility of Writers			Writing for the young adult market	Monster Trivia Quiz/Hosting		Reading by Jean Lorrain	Small Press Publishing	Jurassic Park: The Science Behind the Fiction		Interstellar Propulsion with Known Physics	Interflik Auction pt 1 Instant Band Showcase #2			3:00 PM	
16:00	Politics in SF	Medical Situations in Fiction	SF on Television	KaffeeKatsch			Creating an Internally Consistent Religion	Japanese SF	Reading by Barry B. Longyear	The Kinging Dating Game- Hosted by KAG/Kanada	How I Create a Book Cover Illustration		1998 and Beyond Worldcon Bid Presentations	3:30 - 4:30 Interflik Auction pt2	Panel, Filk past, present & future		4:00 PM	
17:00	Aging Gracefully	Aliens in SF						Convention Burnout	Physics of Star Trek	Reading by Spider and Jeanne Robinson	Cornel Crash!			Instant Band Showcase #3	Panel, Etiquettes of filking		5:00 PM	
18:00												Artemis Project Meeting					6:00 PM	
19:00																	7:00 PM	
20:00									Calling All Mad Scientists: Population Heading to 10 Billion!				Recording & Undependent Co.'s 8:30	One Shots - Filk Performances 8:30	Jam, Always steal from the best 8:30		MASQUERADE - DOORS OPEN AT 7:30	8:00 PM
21:00													Group vs Solo 9:30	Jam, Songs from the books we love 9:30	Jam, Songs of Fantasy 9:30			9:00 PM
22:00													Open Filking 10:30	Open Filking 10:30	Open Filking 10:30			10:00 PM
23:00																		11:00 PM

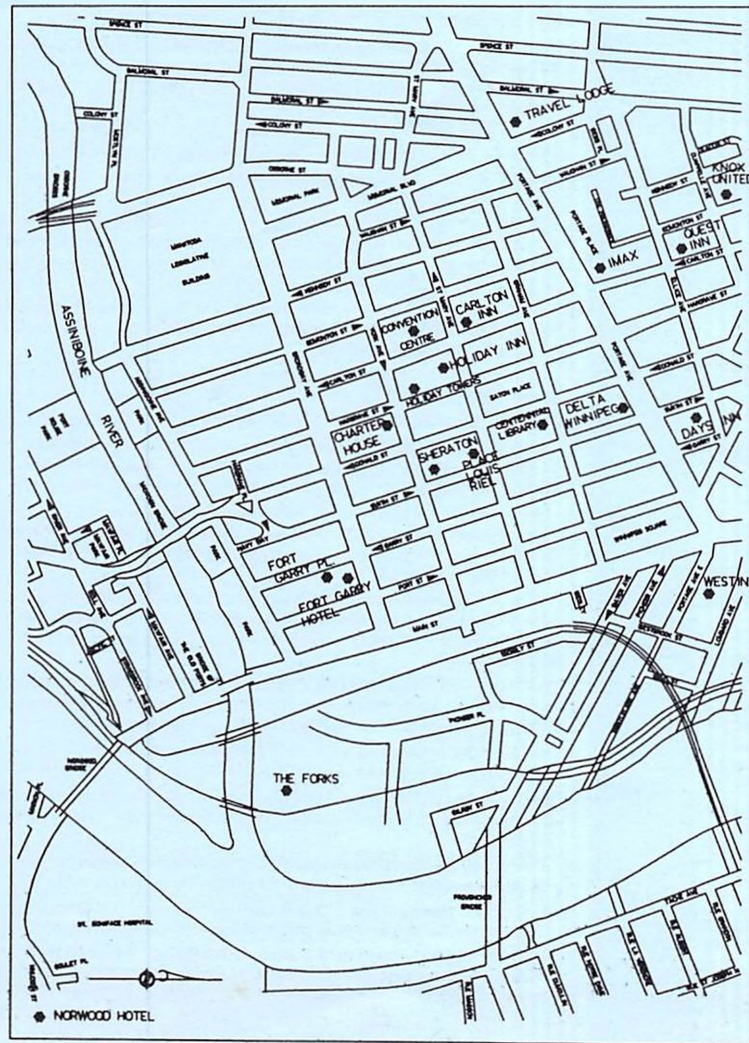

CONVENTION CENTRE

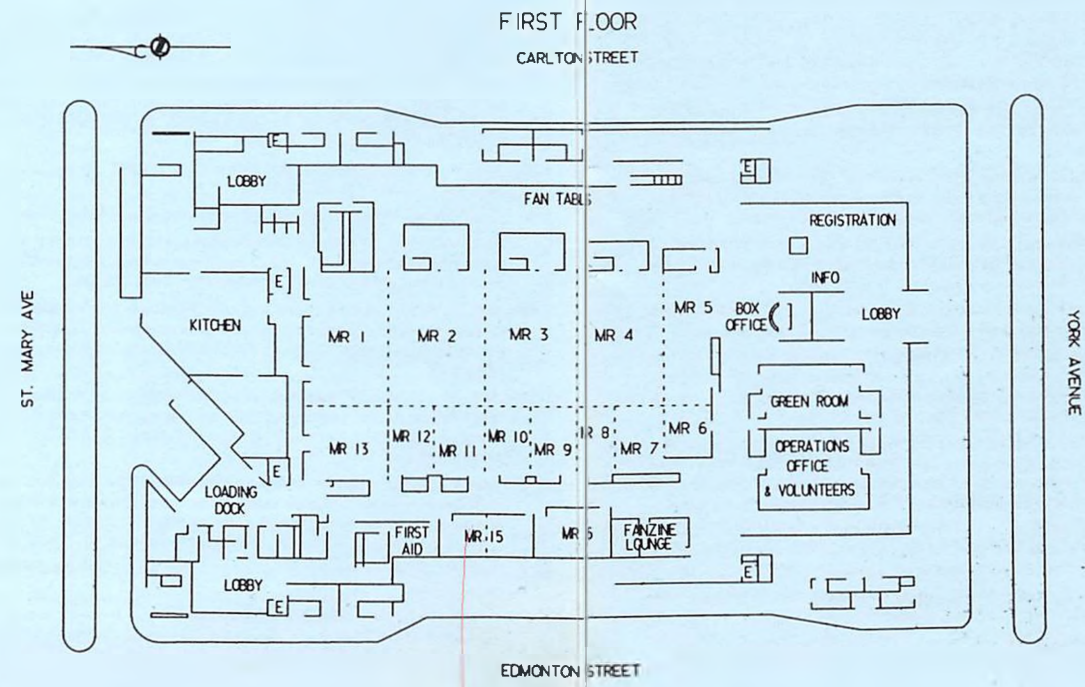

SECOND FLOOR

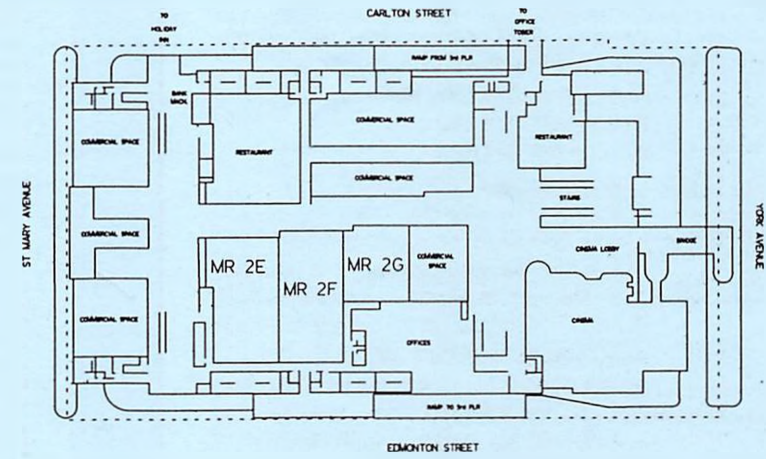

THIRD FLOOR

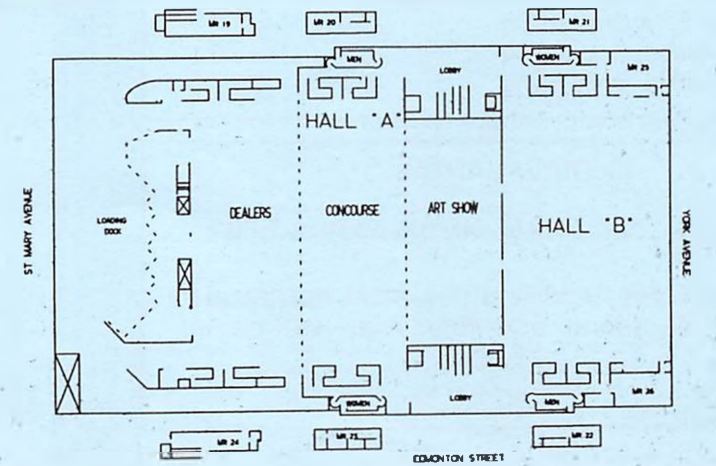

FILK PROGRAM SCHEDULE

- 11:00-12:00 CAMP-S Pegasus Awards, listen & vote
Glenn Simser
- 11:00-12:00 MR16 Workshop, Performance skills with Pete Grubbs sign-up in Filk Lounge
- 12:00-02:00 MR16 Songs from the worlds of Ann McCaffrey
Andrea Yeomans, Judith Hayman, Sylvia Fisher, Diane Sankey, Kathy Mar, Kate Soley, Joey Shoji
- 02:00-03:00 MR16 Instant Band showcase #1
sign-up in Filk Lounge
- 03:00-03:30 MR16 Interfilk Auction part 1
- 03:30-04:30 MR16 Instant Band showcase #2
sign-up in Filk Lounge
- 04:00-05:00 CAMP-S Panel, Filk, Past & Future
Roberta Rogow, Kathy Mar, Bill Roper, David Hayman, Jordin Kare
A look back at where filk has come from, a look forward at the exciting directions it is headed.
- 04:30-05:00 MR16 Interfilk Auction part 2
- 05:00-06:00 CAMP-S Etiquettes of Filking
Bill Roper, Mary Ellen Wessels, Athena Jarvis Can you bring a tuba to a filk circle? What is the difference between chaos and bardic? These and other questions answered.
- 05:00-06:00 MR16 Instant Band showcase #3
sign-up in Filk Lounge
- 08:30-09:30 MR14 Panel, Recording, independents & companies. Bill Roper, Graham Leathers, Jordin Kare, Jodi Krangle, Gretchen Roper, Tom Jeffers
What are the ins and outs of recording?
- 08:30-09:30 MR16 Jam, Always Steal from the Best
Mary Ellen Wessels, Kathleen Sloan, Decadent Dave Clement
sign-up in Filk Lounge
- 08:30-09:30 MR15 One shots, filk performances
sign-up in Filk Lounge
- 09:30-10:30 MR14 Panel, Group vs. solo performing
Stephanie Bedwell-Grime, Pete Grubbs, John Speelman, Graham Leathers, Allison Durno Do you go for safety in numbers or do you go it alone? What are the advantages and drawbacks of each choice?
- 09:30-10:30 MR16 Jam, Songs from the books we love
Joey Shoji, Bill Roper, Judith Hayman, Mary Ellen Wessels
- 09:30-10:30 MR15 Jam, Songs of Fantasy
sign-up in Filk Lounge
- 10:30—> MR14 Open filking
- 10:30—> MR16 Open filking
- 10:30—> MR15 Open filking

EXTRAVAGANZAS

Masquerade 8pm Hall B Doors open at 7:30 pm

The Masquerade is always the most spectacular venue at Worldcon and this year will be no exception.

SUNDAY PROGRAM SCHEDULE

- 09:00 MR 8 4A747 **Aerobics** Exercise for the fanish masses John Douglass
- 10:00 ConCourse 4B816 **Autograph Sessions** Phil Foglio Kaja Foglio David G Hartwell
- 10:00 MR 1 4B107 **How to get Artwork Published, Artists Going Pro** The difference between "fan" and "pro" art and how to place yourself in the market. George Barr Brad Foster Ric Meyers Michael Whelan
- 10:00 MR 2 4B241 **Magic Realism** A discussion on magic, supernatural beings, and the laws of conservation. Mary H Rosenblum Daniel L Marcus Maureen F McHugh Carrie Richerson
- 10:00 MR 4 4B161 **Military SF** How does military SF relate to the real military? Bart Kemper Timothy Lane Howard Scrimgeour Perry Williams
- 10:00 MR 5 4B838 **KaffeeKlatsch** Limited ADVANCE Registration - Inquire at Con Info Desk. Josepha Sherman Jonathan V. Post Briccio Barrientos Charles Pellegrino
- 10:00 MR 7 4B339 **Publishing on the Desktop** How desktop publishing can work for you. Roger MacBride Allen Glenn Hauman Arthur Kyle Jean Lorrach Julia Martin
- 10:00 MR 9 4B072 **Advances in Medicine, Genetics, Technology, Etc.** With all the advances made in recent history, is SF falling behind the curve? Jeri Freedman Maggie Flinn Karl Johanson S. M. Stirling John Strickland Jr.
- 10:00 MR12 4B742 **SFWA Meeting** The Science Fiction and Fantasy Writers of America is an organization founded to inform its membership about matters of professional interest to writers, to promote their general welfare, and to help them deal effectively with publishers, editors and anthologists. The business meeting is closed to the public. Gay Haldeman
- 10:00 MR13 4B788 **Electronic Fiction and Publishing** Hypertext demo with Eastgate Systems Kathryn Cramer
- 10:30 Fort Rouge Park 4B772 **Pagan Ritual** Not a sky clad rite. In other words, you MUST wear clothing to attend. Bill Avery
- 11:00 ConCourse 4C817 **Autograph Sessions** S. M. Stirling Maureen F McHugh
- 11:00 MR 1 4C409 **Future of Space Exploration** What has been happening since Apollo? How can we get to Mars and beyond? Hugh Gregory Gregory Bennett Gerald D. Nordley Henry Spencer David Stephenson Henry Vanderbilt
- 11:00 MR 2 4C386 **Use of Violence in SF** Violence seems to be a way of life now. How has SF encouraged its growth? L Warren Douglas Geoff Ryman Ron Sarti Jean-Louis Trudel Ann Tonsor Zeddies
- 11:00 MR 4 4C612 **Writing with Anne McCaffrey** Meet some writers who have worked in a universe that is known and loved by millions. Jody Lynn Nye Jack Cohen Elizabeth Moon Elizabeth Ann Scarborough
- 11:00 MR 7 4C778 **Cyberspace in Multi-User Dungeons** A demonstration of Virtual Reality MUDs and MOOs. Dr. Joseph Donatelli
- 11:00 MR 9 4C266 **Bioethics Considerations** A discussion of the ethics of bioengineering. Lois H Mangan Genny Dazzo Kathleen Ann Goonan Ross Pavlac J.D. Maynard
- 11:00 MR15 4C249 **How to Sell SF to General Readers as Literature** What's a general reader? What's literature? Possible ways to package SF in order to reach a broader market. Gerri Baller Janice M Eisen Patrick Nielsen Hayden
- 12:00 ConCourse 4D818 **Autograph Sessions** Nancy Kilpatrick Jack Nimersheim Geoff Ryman
- 12:00 MR 1 4D721 **WSFS Business Meeting, Second Main Session** The results of the 1997 Worldcon Site Selection will be formally announced at the beginning of today's meeting. Further debate on amendments to the WSFS Constitution, as well as reports from Worldcon committees, are expected today. All regular business is expected to conclude today, to be followed by Question Time, where you can grill representatives of future Worldcon Committees and Bid Committees. Kevin Standlee
- 12:00 MR 2 4D354 **The Meaning of Dark Fantasy** An exploration into the depths of dark fantasy. Daniel L Marcus K.B. Bogen Stephen Dedman Dawn Dunn P C Hodgell Caro Soles
- 12:00 MR 4 4D408 **Star Wars Novels** Star Wars has captured the hearts of millions. Come learn what is being done now and for the future. Kevin J Anderson Rebecca Moesta Anderson Janna Silverstein Kathy Tyers Tom Dupree
- 12:00 MR 5 4D839 **KaffeeKlatsch** Limited ADVANCE Registration - Inquire at Con Info Desk. Mike Resnick Lee Barwood Chris Rutkowski Shariann Lewitt Robert J Sawyer
- 12:00 MR 7 4D320 **Reach for the Stars/Trivia Contest with Star Trek Regina** Yes it's a trivia game! Come and display your knowledge. Hilary Ryan
- 12:00 MR 9 4D247 **What is REALLY Killing the Backlisting of Good Books** A discussion on the shelf-life of books and how to keep our favorites front and center in the buyer's mind. Joseph T Mayhew Tom Doherty Patrick Nielsen Hayden Robert Runte Shelly Shapiro
- 12:00 MR10 4D385 **Getting Your Stars Right the First Time** Green stars? The Sun going nova? Tau Ceti going supernova? Science fiction can often raise an astronomer's hackles. A review of the stars which do and do not exist, and how to intergrate astronomical assumptions into fiction. Jean-Louis Trudel
- 12:00 MR13 4D379 **The DreamTime Art of the Australian Aborigines** Native Culture, myths and folklore. Stories about mythical creatures like the Rainbow serpent tie in well with SF/F themes. Charlene Taylor
- 12:00 MR14 4D886 **Reading by Harry Stubbs (Hal Clement)** Harry Stubbs (Hal Clement) reads from his own work. Harry C Stubbs
- 12:00 MR15 4D350 **One Language for the World?** The pros and cons of a world-wide language. Dr. Janice Bogstad Myra Cakan Joel Champetier Frederick Andrew Lerner Stanley Schmidt
- 13:00 ConCourse 4E819 **Autograph Sessions** Ellen Dallow Martha Soukup Donald Kingsbury
- 13:00 MR 2 4E441 **How We Deal With Death & Dying** This is something that we all will do at least once in our life, but how do we really feel about it. George Barr Barry B Longyear Lois H Mangan Connie Willis
- 13:00 MR 4 4E402 **Liar's Panel on How to Get Published** So you think you've tried every way possible to get your manuscript accepted... Gene Wolfe Joe Haldeman David G Hartwell John M. Landsberg Wil McCarthy Roger E. Moore
- 13:00 MR 6 4E776 **GnuGnome/Gnome Press Presentation** During the forties and fifties, Dave Kyle's original Gnome Press published first novels by many science fiction legends, including Isaac Asimov and Arthur C. Clarke. GnuGnome Press will attempt to follow in the tradition, publishing limited edition hardcovers devoted to quality science fiction. Ralph Schiano David Kyle Arthur Kyle
- 13:00 MR 9 4E400 **The Library of the World at Your Desk** Explore the world of electronic libraries with those who have already gone before. Michael J Ward Ben Best Billie Aul Marty Helgesen Ken Meltner
- 13:00 MR10 4E887 **Reading by Jack L. Chalker** Jack L. Chalker reads his own work. Jack L Chalker
- 13:00 MR12 4E626 **Dragonriders of Pern Fan Clubs** Opportunity for Dragonrider/Pern fan clubs to meet and discuss fan club interests. Magi Shepley
- 13:00 MR13 4E715 **The Klingon Empire on 5 Credits A Day!** Beware Terrans, the Klingon Empire is taking over Canada and the rest of the planet Earth. Hear about the Kanadian Klign Empire and how you will be conquered/assimilated. A discussion of Klingon culture, rituals, language, and other aspects of this growing part of "Trek" fandom here in Kanada. Bernard Reischl
- 13:00 MR15 4E077 **Non-Monogamous or Non-Heterosexual Relationships** The Moral Majority abhors them; the vast majority is silent. Is it the purpose of SF to de-demonize these types of relationships? Genny Dazzo Stephen Dedman Alexandra Honigsberg George R R Martin
- 14:00 ConCourse 4F820 **Autograph Sessions** Josepha Sherman Bridget McKenna
- 14:00 MR 1 4F242 **Themes of Abuse** Psychological abuse as well as physical abuse is not new. Is fiction another tool for writers and readers to work through and deal with a serious issue? Barry B Longyear Ctein David Drake Kathi Logue William R. Lund
- 14:00 MR 2 4F370 **Gender Roles** How has society shaped our stereotypes and can technology change them. George Barr Cynthia Felice Judith Hayman Mary A Turzillo S. M. Stirling
- 14:00 MR 4 4F362 **The State of SF TV/Movies** How TV and the movies treat Science Fiction. Ric Meyers John L Flynn Stan Hyde Perry Mark Stratychuk
- 14:00 MR 5 4F840 **KaffeeKlatsch** Limited ADVANCE Registration - Inquire at Con Info Desk. Judith Merrill jan howard finder Allen Steele
- 14:00 MR 6 4F779 **Aliens of the 90's** Who are they? What are they? Alien trends and predictions. Dr. Joseph Donatelli
- 14:00 MR 7 4F275 **Breaking Into the Professional Markets** Get some tips from people who have been there. How did they get their first break? Ashley D Grayson Steve Fahnestalk Guy Gavriel Kay Terry Erdmann Betsy Mitchell
- 14:00 MR 9 4F263 **Future of Education** Will education meet the changing requirements of the 21st century? John Hertz Ann L. Chancellor Kathleen Ann Goonan Bradford Lyau Lindalee Sluckey
- 14:00 MR10 4F410 **Importance/Ethics of Terraforming Other Planets** How can we justify this work to the universe? Roger MacBride Allen Frederick Andrew Lerner Stanley Schmidt John Strickland Jr.
- 14:00 MR12 4F333 **SF Vs. Fantasy** Is SF a subset of Fantasy...Or is Fantasy a subset of SF...Or are they both opposite sides of the same coin? J.R. Dunn Dave Duncan Claire Eddy Alexis A Gilliland Jennifer Hershey
- 14:00 MR13 4F727 **Breaking into Screenwriting** Gillian Horvath, who broke into screenwriting with the Quantum Leap episode "Promised Land", shares some of the do's and don'ts of the town where, as William Goldman put it, Nobody Knows Anything. Gillian Horvath
- 14:00 MR15 4F888 **Reading by Jean-Louis Trudel** Jean-Louis Trudel reads his own work. Jean-Louis Trudel
- 15:00 ConCourse 4G821 **Autograph Sessions** Elizabeth Ann Scarborough
- 15:00 MR 1 4G319 **Does our Culture Have a Myth System?** Explore how myths, both ancient and modern, are shaping our culture. Claire Eddy Laura Frankos Janet Hetherington David Honigsberg Julia Martin
- 15:00 MR 2 4G617 **Let's Drive A Stake Through The Romantic Vampire** What to do when your character has fallen in love with a perfectly good symbol of evil. Janeen Webb Stephanie Bedwell-Grime Beverley Richardson Nancy Kilpatrick
- 15:00 MR 4 4G395 **SF and Social Responsibility of Writers** Of course we are responsible to our society. The question is: are we doing enough? Sandra Morrese Stephen Burns L Warren Douglas Dawn Dunn Ian K Hagemann Amy Thomson Anne McCaffrey
- 15:00 MR 7 4G010 **Monster Trivia Quiz/Hosting** This your opportunity to test your knowledge of those dark creatures out of man's imagination. Three rounds of monster trivia. Winners will receive monster prizes. Hosted by the Monster Club. Compete as teams or individuals, open to all. Raul Andreu
- 15:00 MR10 4G889 **Reading by Jean Lorrach** Jean Lorrach reads her own work Jean Lorrach
- 15:00 MR12 4G282 **Small Press Publishing** A small press shop vs. the big monsters of the industry. Who can serve you better? Michael J Ward Jim Groat Derryl Murphy Jack Nimersheim Ralph Schiano Gene Wolfe Andrew Porter

PROGRAM ROOM LOCATIONS

HALL "B" - 3rd floor of the Wpg Convention Center
MR 2EFG - 2nd floor of the Wpg Convention Center
MR 1 thru 15 - 1st floor of the Wpg Convention Center
WEST - Westminster Room West 2nd floor Holiday Inn
Concourse - 3rd floor of the Wpg Convention Center
Con Cont Loop - WCC outside main entrance 1st floor
CAMP-S - Campaign rm "South" 2nd floor Holiday Inn
Science Channel Videos - 5th flr Charter House Hotel
Japanese Animation - Lower Level Charter House Hotel
British Video Room - 3rd flr Charter House Hotel
Writers Workshops - Sheraton Hotel
Gaming - Place Louis Reil

- 15:00 MR13 4G299 **Jurassic Park: The Science Behind the Fiction** From the scientist who invented the dinosaur cloning recipe that became Jurassic Park...an in depth look into the science behind the fiction. Charles Pellegrino
- 15:00 MR15 4G286 **Interstellar Propulsion with Known Physics** How science can help us explore outer space. Geoffrey A Landis Howard Davidson Karl Johanson Waldemar Kummering Gerald D. Nordley
- 16:00 ConCourse 4H822 **Autograph Sessions** Connie Willis Dr. Arlan Andrews Mike Resnick
- 16:00 MR 1 4H284 **Politics in SF** Literature has always been a medium for expressing and critiquing politics. How can this help or hinder your story? Alexis A Gilliland J.R. Dunn Janice M Eisen Astrid Julian Maureen F McHugh
- 16:00 MR 2 4H090 **Medical Situations in Fiction** Today's reader is too sophisticated to allow magic in medicine. So how can you create a believable medical scenario? Judy Lazar Joel Champetier Lois H Mangan Elizabeth Moon Howard Scrimgeour
- 16:00 MR 4 4H280 **SF on Television** What are the pro's and con's of a mass audience tool like TV? After all, more people watch TV than read books. Gillian Horvath John L Flynn William R. Lund George R R Martin Craig Miller
- 16:00 MR 5 4H841 **KaffeeKlatsch** Limited ADVANCE Registration - Inquire at Con Info Desk. Kevin J Anderson Betsy Mitchell
- 16:00 MR 7 4H330 **Creating an Internally Consistent Religion** Every culture must have some sort of religion to hold it together, but can it be as easy as the "Great Potato" theory? Harry Turtledove William "Wolf" Foss John Hertz Robert Sawyer David Wixon
- 16:00 MR 9 4H749 **Japanese SF** The literature of Science Fiction as it appears in Japan Masamichi Osako Takumi Shibano Miho Hiramoto Anthony Bryant
- 16:00 MR10 4H890 **Reading by Barry B. Longyear** Barry B. Longyear reads his own work. Barry B Longyear
- 16:00 MR12 4H716 **The Klingon Dating Game-Hosted by KAG/Kanada** The Dating Game as you've never seen it. Our Klingon, and other-worldly, contestants compete against one another for the sheer fun of it. Who knows—you, or they, may get lucky with an "out of this world" gal or guy! Bernard Reischl
- 16:00 MR13 4H759 **How I Create a Book Cover Illustration** It takes more than a half-naked lady to do the job these days. How to do justice to the book and still be artistic and creative. Michael Whelan
- 16:00 MR15 4H735 **1998 and Beyond Worldcon Bid Presentations** Meet the people who want to host a worldcon. Mike Glyer
- 17:00 ConCourse 4I823 **Autograph Sessions** Lee Barwood Carlo Soles
- 17:00 MR 1 4I082 **Agling Gracefully** In our youth we fought against "The Establishment," and now we are Them. How does this define society? Marjii Eilers Clifton Ambsbury Leslie Gadallah George (Lan) Laskowski Carrie Richerson
- 17:00 MR 2 4I309 **Aliens In SF** Hollywood has given us many examples of life from another planet, but would we know one if it bit us on the nose? Jack Cohen Stan Hyde John M. Landsberg Anne McCaffrey Wil McCarthy Beth Meacham
- 17:00 MR 9 4I625 **Convention Burnout** Do you feel like the only reason you came was to collect another badge for your wall? Here's some help on removing or avoiding the problem. Kathi Logue David Stein, DI Perrienne Lurie Michael Wallis
- 17:00 MR 10 4I781 **The Physics of Star Trek** A discussion of matter/antimatter conversion, faster-than-light travel and subspace communication in the Star Trek Universe. Dr. Art Sinner Dr. Kumar Sharma
- 17:00 MR12 4I891 **Reading by Spider and Jeanne Robinson** Jeanne and Spider Robinson read their own work. Jeanne Robinson Spider Robinson
- 17:00 MR13 4I769 **Comet Crash!** Video, slides, discussion, and more of the Great Comet Crash! Terry J. Jones David Stephenson Hugh Gregory John Strickland Jr.
- 18:00 MR13 4I738 **Artemis Project Team Meeting** Organization Meeting on the commercial lunar base Gregory Bennett
- 20:00 HALL "B" **Masquerade** Doors open at 7:30 pm The Masquerade is always the most spectacular venue at Worldcon and this year will be no exception.
- 20:00 MR12 4L708 **Calling All Mad Scientists: Population Heading to 10 Billion!** The dangers of overpopulation and what we could do about it. Astrid Julian Leslie Gadallah Karl Johanson David Stephenson David Wixon

TIME	MEETING ROOM 1	MEETING ROOM 2	MEETING ROOM 4	MEETING ROOM 5	MEETING ROOM 6	MEETING ROOM 7	MEETING ROOM 8	MEETING ROOM 9	MEETING ROOM 10	MEETING ROOM 12	MEETING ROOM 13	MEETING ROOM 14	MEETING ROOM 15	MEETING ROOM 16	CAMP SOUTH	OTHER LOCATIONS	TIME
9:00																	9:00 AM
10:00	The Fiction of Anne McAulrey/Academic Papers	Defining SF						Religion & SF	The Special Appeal of Short Stories in SF&F		Apollo: 25 Years Later						10:00 AM
11:00	Where Field (SF, Fantasy and Horror) is Going	Cyberculture				The Geography of Space		Archeology of the Future			Collecting SF Film & Toy Memorabilia		SF Jeopardy!	Song Writing Comp Judging			11:00 AM
12:00	Scientific Accuracy in SF	Safe Sex in SF: A Writer's Obligation?				What Fans Would Like to See at NASFiC (Atlanta) in 1995		Surviving Your First Masquerade	How to Research in Historical Matters for Story		The Geology of Middle Earth		What Is and Isn't Filk			Mark Protection Committee Meeting - West	12:00 PM
13:00	Getting the Medicine/Biology Right	Time Travel Which Alters History						Teaching Science Fiction at the University Level						How to survive running a filk con			1:00 PM
14:00	Robert A. Heinlein	Adapting Real History/Anthropology Backgrounds												Canadian Filking... Beefs & Bouquets			2:00 PM
15:00	Winnipeg Worldcon Convention Critique, Gripe Session															CLOSING CEREMONIES HALL "B"	3:00 PM
16:00																	4:00 PM
17:00																	5:00 PM
18:00																	6:00 PM
19:00																	7:00 PM
20:00																	8:00 PM
21:00																	9:00 PM
22:00																	10:00 PM
23:00																	11:00 PM

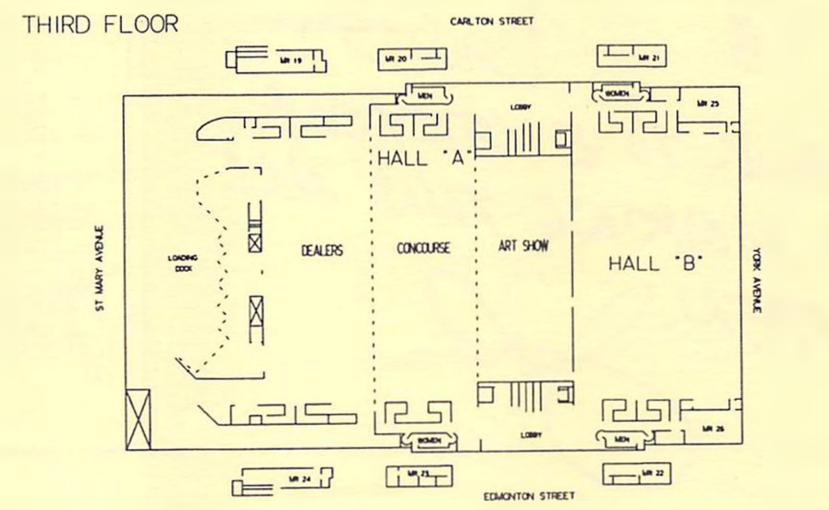
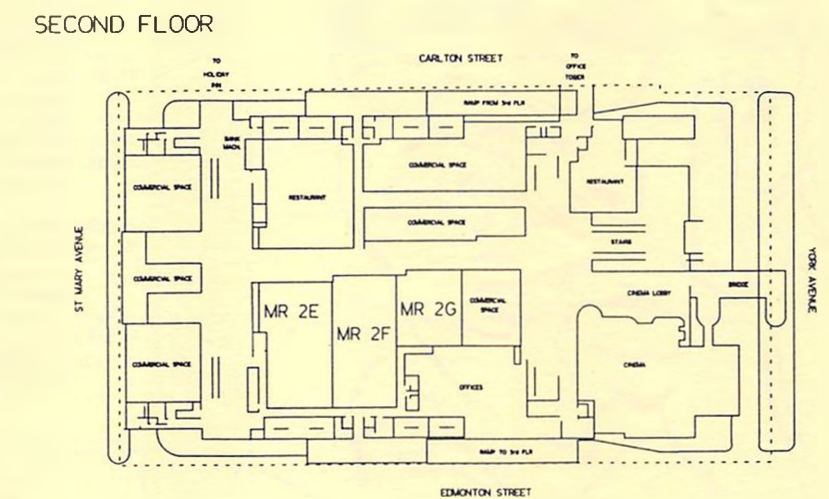
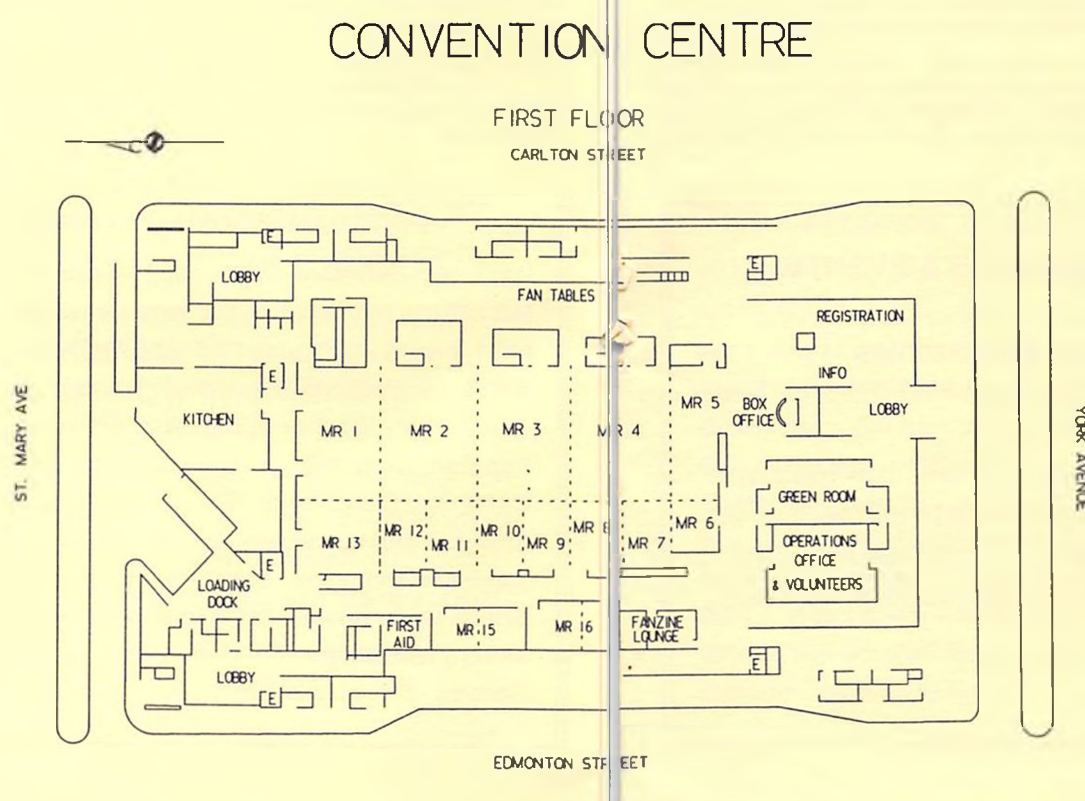
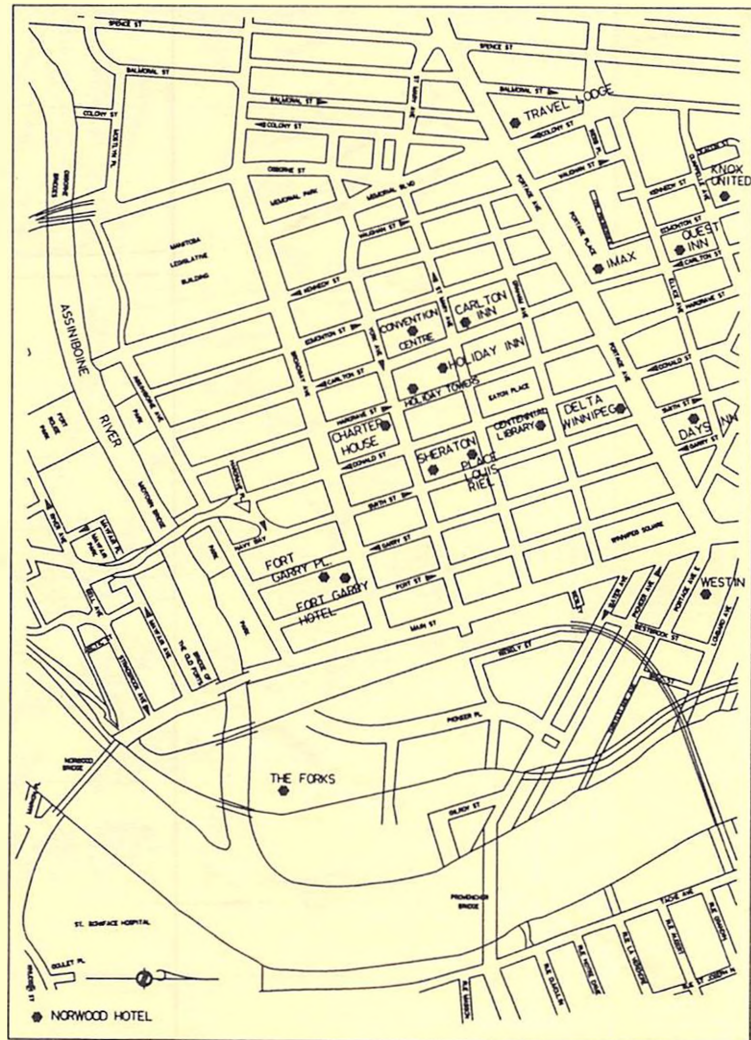

DUST RHINOC



L I V E

FRIDAY SEPT. 2nd

Dead Dragon Inn

PLACE LOUIS RIEL (MARVIN GARDENS ROOM)

DAY 2 - FRIDAY SEPT 2/94 - continued

- 15:00 MR 1 2G342 **Pern Trivia/Hosting** The Pern Trivia contest will be run as a combination of Jeopardy and Trivial Pursuit. There will be 4 groups of 3, the winner being the group with the highest score in 4 games. Categories include: Pern heraldry, Weyrs, Holds, Crafts, Food & People. Magi Shepley
- 15:00 MR 2 2G459 **Babylon Five Panel** The action, the characters, the special effects. Is it television SF's "last, best hope?" Gerri Balter Franklin Hummel Perrienne Lurie
- 15:00 MR 4 2G033 **World Building** Haven't we all read stories where the writer got so involved in building the world that they lost the story? Roger MacBride Allen David Drake Dave Duncan Larry Niven Harry C Stubbs Jack L Chalker
- 15:00 MR 6 2G780 **The Archeology of Slasher Films** A discussion of the significance of horror movies in our society. Dr. Carl Matheson
- 15:00 MR 7 2G687 **Magic Meets Technology** Techno-babble Vs. Fairy Woo-Woo. Whose wand is stronger? Claire Eddy Glenn Battis Robert Charrette Daniel Fresnot Janice M Eisen Mark Shepherd
- 15:00 MR 9 2G148 **Soviet Space Disasters** A discussion of Russian space technology and political concerns. Jordin Kare Jonathan V. Post Hugh Gregory Andre Lieven
- 15:00 MR10 2G024 **How to Form a Writer's Group** So you have decided to publically declare your insanity and become a writer. How do you find similar souls and how can they help your dream? M Shayne Bell Cynthia Felice Sally McBride
- 15:00 MR13 2G728 **Bantam Books Presents** A slideshow and panel presentation which will preview science fiction and fantasy publications coming from Bantam Spectra Books over the next several months, presented by the staff of Spectra. Color slides will feature artwork from upcoming titles. Jennifer Hershey Tom Dupree Janna Silverstein Christian Waters
- 15:00 MR14 2G713 **Winnipeg Doctor Who/Blake's 7 Fan Club (Tardis 204), Club Meeting** All interested may attend. Anna Boudreau
- 15:00 MR15 2G875 **Reading by Connie Willis** Connie Willis reads her own work. Connie Willis
- 16:00 ConCourse 2H806 **Autograph Sessions** Anne McCaffrey (members A-L, 2 book limit) Kevin J Anderson Peter Nicholls
- 16:00 MR 1 2H049 **To Be a Female Writer** The "glass ceiling" — alive and well in SF&F. Stephanie Bedwell-Grime Myra Cakan Nancy Kilpatrick Elizabeth Moon Carrie Richerson Elisabeth Vonarburg
- 16:00 MR 2 2H677 **Can Technology Help Us Save/Manage Our World** Have we as a people matured fast enough to keep pace with technology, or are we just playing God? Gail S Abend Leslie Gadallah Bart Kemper Bradford Lyau Daniel L Marcus
- 16:00 MR 4 2H331 **The Use of Science in Fantasy** If a sufficiently advanced science could appear as magic, couldn't magic also appear as science? Alexis A Gilliland Betsy Mitchell Geoff Ryman Dr. William Sarjeant Robert Silverberg
- 16:00 MR 5 2H833 **KaffeeKlatsch** Limited ADVANCE Registration - Inquire at Con Info Desk. Joe Haldeman P C Hodgell Barry B Longyear Jody Lynn Nye Charles C Ryan
- 16:00 MR 6 2H785 **"IMP's" Meeting** Writers Group Meeting Louise Rowder
- 16:00 MR 7 2H876 **Reading by Kristine Kathryn Rusch** Kristine Kathryn Rusch reads her own work. Kristine Kathryn Rusch
- 16:00 MR 9 2H227 **Designing Diseases** A discussion of disease and how it works to help you in your world. Shariann Lewitt Jeri Freedman Ian K Hagemann Judy Lazar Perrienne Lurie J.D. Maynard
- 16:00 MR10 2H144 **How to Edit** How to read like an editor. Ginjer Buchanan Ellen Dallow Scott Edelman Josepha Sherman Janna Silverstein Shawna McCarthy
- 16:00 MR12 2H732 **What is Magic, the Game?** Learn about the new game that's taking over the gaming tables everywhere. Susan Mohr
- 16:00 MR13 2H011 **Musing with Muuse (tm)—Applications of Virtual Reality** Muuse (tm)—Multidimensional User-oriented Synthetic Environment—is a unique new Virtual Reality shell invented by Dr. Creve Maples and Craig Peterson of Sandia National Laboratories in New Mexico. Dr. Andrews has worked with inventors to apply VR principles to practical engineering problems for industry. Dr. Arlan Andrews
- 16:00 MR15 2H235 **OnLine Communities** What do you think like is like in a virtual community? Can you still have safe sex in a virtual relationship? Alexandra Honigsberg Marty Helgesen Ken Meltsner Terry O'Brien Henry Spencer
- 17:00 Concourse 21807 **Autograph Sessions** Jeanne Robinson Spider Robinson Robert J. Sawyer

DAY 2 - FRIDAY SEPT 2/94 - continued

- 17:00 MR 1 2I352 **What to do When Universal Translator Breaks Down** The problems of communication between completely different cultures. Timothy L Smith Gail S Abend Roger Burton-West Greg Costikyan Kate Soley
- 17:00 MR 2 2I563 **Is Modern SF A Reactionary Literature?** Is SF currently reactionary against mainstream literary ideas, against "society's" ideas, or against itself? Peter Nicholls Daniel Fresnot Dr. Elizabeth Anne Hull J.R. Dunn Martha Soukup
- 17:00 MR 7 2I688 **Christian Fandom Meeting** Christian fandom meeting. General discussion of science fiction in relationship to Christianity. Primary interest to Christian fans but all are welcome. Marty Helgesen Ross Pavlac G. F. Proechel Kathy Tyers
- 17:00 MR 8 2I877 **Reading by S. M. Stirling** S. M. Stirling reads own work. S. M. Stirling
- 17:00 MR 9 2I541 **Being A Pagan in Professional Society** What defines "pagan" in today's society? Does admitting to such hurt one's ability to deal with certain segments of society? How can you deal with it? Julia Martin Sue-Ryn Hildenbrand-Burns
- 17:00 MR10 2I773 **Introduction to Play-by-Mail Gaming** Play-by-Mail Gaming originated in the early 1800's. Learn why it is one of the fastest-growing segments of gaming today. A brief history of PBM will be presented, as well as an introduction into modern PBM game systems. Specific questions on the "Legends" PBM game system will be addressed. Simon Parkinson
- 17:00 MR12 2I736 **Bheer Home-Brewing** Home-brewing bheer with demo and samples from Canadian home-brewing supply house, Brewers Direct William "Wolf" Foss Rick Foss George Flentke Lise Otto
- 17:00 MR13 2I723 **So What's A Science Fiction 'Garage' Kit?** Slide show introduction to the field of resin, vinyl and plastic figure kits. Stan Hyde
- 17:00 MR14 2I044 **Balancing Writing With Family** Little Sally has a dance recital, Billy has a soccer game, the Baby is teething, my Protagonist faces death, and I haven't made love to my Spouse in two weeks — Who wins? Mary H Rosenblum Laura Frankos William R. Lund Sandra Morrese Ann Tonsor Zeddies
- 17:00 MR15 2I764 **Books through the Internet** BiblioBytes started selling and distributing books via the Internet in July, 1994. Their publications includes books by Barry B. Longyear, Nancy Kress, Spider Robinson, Parke Godwin, Octavia E. Butler, Ron Gouliart, John Belancourt and Harlan Ellison. Glenn Hauman
- 19:00 MR 2 2J787 **The Hatching** A live pernese-style hatching in honour of Anne McCaffrey. Pre-registration is required at the Living Fiction's fan table. Dee McLoughlin
- 19:00 MR 6 2K770 **Jewish Sabbath Services** Traditional Orthodox service for all wishing to attend. Head coverings required for male attendees.
- 19:30 RM2EFG **The Gather** In honour of guest-of-honour Anne McCaffrey, we are presenting a Pernese Gather with dragon decorations and a variety of performer's and dancers in proper Pernese tradition. Pernese refreshments will be served to guests. There will be prizes awarded in various categories relevant to the evening - so dress in your finest costumes.
- 20:00 MR 7 2L629 **Electronic Publishing** What is the future of SF in the electronic age? Ginjer Buchanan Glenn Hauman Greg Costikyan Shelly Shapiro Moshe Feder
- 20:00 MR13 2L195 **Getting Off the Rock** There's more than one way to get there! Alternative methods of space launch. Jordin Kare
- 20:30 MR 1 2L674 **Regency Dance** The English Regency period (about the year 1800) was a colorful, whimsical time that appeals to the fannish sense of humor. At ConAdian we'll dance Friday evening. Come in costume, or come as you are. And don't worry if you can't dance. Our host, John Hertz, will teach you.
- 21:00 MR 2 2M783 **Star Trek Parody, Standard Orbit Players** Ahead warp speed with the Standard Orbit Players and their Star Trek presentation. It's funny; it's irreverent; it will make Spock blush to the tips of his pointed ears.
- 21:00 MR 7 2M250 **What Should Have Made it on to the Hugo Ballot, But Didn't** A moderated group discussion of what (or who) should have, but didn't make it onto this year's Hugo ballot. Joseph T Mayhew
- 21:00 MR12 2M622 **Trends in Horror** How is the horror story changing in today's world? Kathryn Cramer Dawn Dunn Mary A Turzillo Dale Sproule
- 21:00 MR13 2M722 **How to Design Credible Aliens** Dr. Cohen works with SF authors, including Anne McCaffrey. Jack Cohen
- 22:00 MR 7 2N604 **Pictionary: Artists Vs Authors** Watch them sweat against the clock. Who is better at placing words to a picture? Geoff Ryman Rebecca Moesta Anderson Phil Foglio Kaja Foglio John M. Landsberg

DAY 2 - FRIDAY SEPT 2/94 - continued

- 22:00 MR13 2N243 **Bad Movies** We've all seen them. We've really loved some of them. Why are some bad movies just so darn good? Stan Hyde Michael Skeet Ric Meyers
- 23:00 MR 7 2O088 **PG/Multiculturalism and its Influence on SF** Can you be politically correct and still like SF? J.R. Dunn Clifton Amsbury Ian K Hagemann Astrid Julian Ron Sarti
- 23:00 MR 12 2O632 **Vampires: Fact, Fiction, and Myth** Vampire stories have been around for as long as acne. How did they begin, how have they changed, and can they still be living among us? Lee Barwood Stephanie Bedwell-Grime Joshua Bilmes Daniel Dvorkin Alexandra Honigsberg
- 24:00 MR 7 2P000 **Midnight Horror Readings** Readings open to at con sign-up. Participants TBA in newzine. Scott Welch Nancy Kilpatrick
- 24:00 MR13 2P091 **Alternative Music** Every generation believes it has found something new. How can you tell when it is out? Pras Stillman Daniel Duorkin Jordin Kare

DAY 3 - SATURDAY SEPT 3/94

- 09:00 MR 6 3A771 **Jewish Sabbath Services** Will read from the bible in hebrew and have a public prayer. Need at least 10 men for the service, espically welcome those who can read hebrew.
- 09:00 MR 8 3A746 **Aerobics** Exercise for the fanish masses. Come on, it's good for you! John Douglass
- 10:00 Concourse 3B808 **Autograph Sessions** Anne McCaffrey (members M-Z, 2 books only) Richard Knaak Len Wein
- 10:00 MR 1 3B733 **What is Upcoming with WOTC & Magic** What's next from the people who developed Magic, the game? Susan Mohn
- 10:00 MR 4 3C726 **Highlander: The Series and the Movie** The staff of the Los Angeles office of Highlander: The Series takes you through the process of creating an episode. Also: A preview of the upcoming Highlander III movie, and tidbits on the new season of the series. Q & A follows. Gillian Horvath Donna Lettow
- 10:00 MR 5 3B834 **KaffeeKlatsch** Limited ADVANCE Registration - Inquire at Con Info Desk. Roger MacBride Allen Ginjer Buchanan Edward Kramer Elizabeth Moon Jean-Louis Trudel
- 10:00 MR 7 3B878 **Reading by Josepha Sherman** Josepha Sherman reads her own work Josepha Sherman
- 10:00 MR10 3B730 **Model Contest, Second Session** Models on show in the Art Show. Sheila Adler Barry Adler
- 10:00 MR12 3B093 **Running SF Clubs/Libraries** So you want to share your personal love. Here are some tips on starting and maintaining a successful club. Michael Wallis Jill Eastlake Robert Runte Henry Welch Fred Patten D.I. Stein
- 10:00 MR13 3B193 **Reviewing/Criticism** What is the difference between a reviewer and a critic? How can you be a successful one? Dean Wesley Smith Rick Foss Ashley D Grayson Paula Johanson Kristine Kathryn Rusch Janeen Webb Tom Whitmore
- 10:00 MR15 3B224 **Behind-the-Scenes of Publishing & Sales** Can artistic and editorial creativity survive in a business driven by sales? Susan Allison Ian Ballantine Betty Ballantine Tom Doherty Kuo-Yu Liang David Wixon
- 10:00 Place Louis Riel 3B768 **SFRA Breakfast** Held in Diane Miller's suite at the Place Louis Riel. Diane Miller
- 11:00 ConCourse 3C809 **Autograph Sessions** M Shayne Bell Scott Edelman Fredrick Pohl
- 11:00 MR 1 3C062 **Ozone Hole** Is it real or just a hoax by Big Business to force a costly conversion to a new product? Timothy Lane Keith G. Kato Clein Leslie Gadallah Karl Johanson
- 11:00 MR 2 3C222 **Alternate Canadas** As Canada moves from crisis to crisis, can stability come from merging with the U.S.? Robert Sawyer Glenn Grant Evelyn Leeper Andre Lieven Deryl Murphy David Nickle
- 11:00 MR 6 3C037 **Cryonics: Time-Capsule to the future?** Is freezing a way to get to the future? What would it be like for the reanimnees? Presentation by the Cryonics Society of Canada. Ben Best
- 11:00 MR 7 3C000 **1995 Library of Canada SF & Fantasy Exhibit** Presentation of the upcoming exhibit at the National Library in Ottawa, with a side exhibit at The Merril Collection.
- 11:00 MR12 3C163 **How to Survive & Enjoy An SF Convention** Or...Can I really survive on stale popcorn and flat Diet Coke for four days? Gay Haldeman Gerri Balter David W Clark David Hayman George (Lan) Laskowski Murray Rogov
- 11:00 MR13 3C879 **Reading by Joe Haldeman** Joe Haldeman reads his own work. Joe Haldeman

DAY 3 - SATURDAY SEPT 3/94 - continued

- 11:00 MR15 3C762 **SF Jeopardy!** What famous TV show has been set up for SF fans. Teams of 3 to compete. Final session Monday. Doug Kemp
- 12:00 ConCourse 3D810 **Autograph Sessions** Shariann Lewitt Harry Turtledove Carrie Richerson
- 12:00 MR 1 3D720 **WSFS Business Meeting, First Main Session** Today, amendments to the WSFS Constitution will be debated and voted on. Also, reports from Worldcon committees and the elections to the WSFS Mark Protection Committee are expected. If you are a member of ConAdian, you are a member of WSFS and are welcome to attend this meeting and participate in the debate. Kevin Standlee
- 12:00 MR 2 3D048 **Shared World Fiction** I created this world — How dare you blow it up with nukes! George R R Martin Joshua Bilmes Robert Charrette Peter J Heck Sasha Miller
- 12:00 MR 4 3D106 **Books that Changed my Life** An introspective look into a first love that turned into a life-long obsession. Marjii Ellers Joel Champetier Anne McCaffrey Alan Stewart
- 12:00 MR 5 3D835 **KaffeeKlatsch** Limited ADVANCE Registration - Inquire at Con Info Desk. Greg Costikyan William "Wolf" Foss David G Hartwell Patrick Nielsen Hayden Bridget McKenna
- 12:00 MR 7 3D880 **Reading by Guy Gavriel Kay** Guy Gavriel Kay reads his own work Guy Gavriel Kay
- 12:00 MR 9 3D332 **Folk Music in SF/F** Can or should the folk ballad be used for fantasy stories? Has this ever been done successfully? What is the role of folk music in the future of mankind? Elizabeth Ann Scarborough
- 12:00 MR10 3D631 **Nuts and Bolts of Game Publishing** The how-to guide to help you break into the industry. Roger E. Moore Julia Martin Sue Weinlein
- 12:00 MR12 3D450 **Fandom in Russia** This event will be devoted to our history and current situation in our fandom, and not only in Russia but all C.I.S.'s. Yuri Savtchenko
- 12:00 MR13 3D657 **Enduring Myths (Robin Hood, King Arthur, others)** Why do some stories continue to live on when others die so young? Jean Lorrain Ann L. Chancellor Mary Cannings Terry O'Brien Lorna Toolis
- 13:00 ConCourse 3E811 **Autograph Sessions** Roger MacBride Allen Dave Wolverton Elisabeth Vonarburg
- 13:00 Library 3E566 **Convention Meeting, SF Canada Meeting** The Canadian Science Fiction and Fantasy Association, a non-incorporated, non-profit body, will hold its annual business meeting and decide upon the site of the next Convention. Open to all Convention members (i.e. ConAdian members who are either Canadian citizens or permanent residents, or paid-up Convention members.) Jean-Louis Trudel
- 13:00 CAMP-S 3E098 **SF Films** A discussion of SF from Hollywood: The good, the bad, and the cyberpunk. Steve Fahnestalk Myra Cakan John M. Landsberg Mark Leeper Craig Miller Michael Skeet
- 13:00 MR 2 3E724 **Interview of George Barr** by Karen Haber Karen Haber (Silverberg) is an experienced artist interviewer. Karen Haber George Barr
- 13:00 MR 4 3E731 **Canadian Astronaut Talk and Autographs** Marc Garneau, the first Canadian Astronaut to rocket into space talks about his personal experiences in space. He will also describe the specialized astronaut training he is currently undergoing at NASA. Marc Garneau
- 13:00 MR 8 3E196 **Shotokan Karate Workshop** Con-goers (12 years and older) are invited to participate in a one-time training session in the dynamic martial art of Skotokan karate. This session will be non-strenuous and safe, concentrating on basic karate mechanics. Participants should wear loose clothing Keith G. Kato
- 13:00 MR 9 3E881 **Reading by Mike Resnick** Mike Resnick reads his own work. Mike Resnick
- 13:00 MR12 3E124 **Journey of the Hero** What should the Hero's journey mean to us? Can we identify with the journey? Lee Barwood David Drake Janeen Webb K. D. Wentworth Ann Tonsor Zeddies Jack L Chalker
- 13:00 MR13 3E149 **Russian Interplanetary Probes** A look back across 30 years of Soviet Interplanetary exploration, in particular the probes for Venus and Mars made by the Lavochkin Association. Photos of the actual engineering models that were used to test and work out problems on the spacecraft before they were launched and while in flight. Hugh Gregory
- 13:00 MR14 3E884 **Reading by Charles Sheffield** Charles Sheffield reads his own work Charles Sheffield

DAY 3 - SATURDAY SEPT 3/94 - continued

- 13:00 MR15 3E053 **Short Fiction Vs. Longer Fiction Forms** Short fiction, novellas, and novels. It's only the word count, right? Sandra Morrese Gardner Dozois Nancy Kilpatrick Maureen F McHugh Mary H Rosenblum Shawna McCarthy
- 14:00 ConCourse 3F812 **Autograph Sessions** C J Cherryh Kristine Kathryn Rusch Mark Shepherd
- 14:00 Library 3F743 **SF Canada Business Meeting** Meeting only open to members of SF Canada. Jean-Louis Trudel
- 14:00 MR 1 3F269 **Humor in our Genre** Laughter is an important part of living. Why don't we see more of it in SF? Dr. Arlan Andrews Susan Casper Janet Hetherington K. D. Wentworth Connie Willis
- 14:00 MR 2 3F211 **Celtic Mythology** Why does Celtic mythology survive and thrive when so many others have not? Guy Gavriel Kay Roger Burton-West Josepha Sherman Kate Soley Lindalee Stuckey
- 14:00 MR 5 3F836 **KaffeeKlatsch** Limited ADVANCE Registration - Inquire at Con Info Desk. Cynthia Felice Jack L Chalker Jack Dann Martha Soukup Michael Whelan
- 14:00 MR 7 3F178 **Electronic Fandom** What's the on-line fannish community and how do you join? Ken Meltsner Glenn Battis Marly Helgesen Saul Jaffe Maia Cowan
- 14:00 MR 9 3F137 **How to Do Costuming (Costuming 101)** So you want to get into costuming, but you don't know where to start. Some tips and suggestions for the novice from those who have been there. Marjii Ellers Stephanie Ann Johanson Pierre E Pettinger Jr Sandra G Peltinger
- 14:00 MR10 3F882 **Reading by Geoff Ryman** Geoff Ryman reads his own work. Geoff Ryman
- 14:00 MR12 3F209 **Economic/Political Aspects of Future History** Are we moving toward a global economy or just re-entering the Dark Ages? Philip Kaveny Briccio Barrientos M Shayne Bell David Hayman Timothy Lane
- 14:00 MR13 3F346 **Fandom & Convention in Japan** SF and fan activity in Japan. A view of Japan's 33rd national convention held on Olinawa Island. Takumi Shibano Masamichi Osako Ken Yamaoka
- 15:00 ConCourse 3G813 **Autograph Sessions** Robert Silverberg Karen Haber Gregory Bennell
- 15:00 Library 3G744 **Aurora Awards** Canadian Awards, similar to Hugos, for best novel in English / French, short story, fanzine, etc. Held This will be an all-Canadian, all-star event. Expected are Marc Garneau, Judy Merrill, R.S. Sawyer and so many more you wouldn't believe it! Jean-Louis Trudel
- 15:00 MR 1 3G378 **Golden Duck Awards** The Golden Duck Award is for excellence in children's SF. Come and hear about the best of children's science fiction today and see slides of science fiction picture books. These awards are sponsored by Duckon, a science fiction convention near Chicago. Presenters: Lindalee Stuckey, Trudi Puda, Helen Gbala, Douglas Drummond. Lindalee Stuckey
- 15:00 MR 2 3G328 **Dinosaurs in SF** An exploration of the recent glut of dinosaurs after being extinct for 65 million years. Ric Meyers Richard Chwedyk Stephen Dedman Stan Hyde Hayford Peirce Beth Meacham
- 15:00 MR 7 3G190 **Putting a Zine Together** Tips on starting and improving your 'zine. George (Lan) Laskowski Cindy Huckle Timothy Lane Magi Shepley Henry Welch Andrew Porter
- 15:00 MR 9 3G031 **The Value of Regular Writer's Groups** So you have found a group you like, but are they really helping you? Isn't writing supposed to be a "solitary" pursuit? Anthony Bryant Janice M Eisen Adrienne Foster Astrid Julian Geoffrey A Landis Michael Skeel
- 15:00 MR10 3G883 **Reading by George R. R. Martin** George R. R. Martin reads his own work. George R R Martin
- 15:00 MR12 3G272 **Women in Combat** Let's face it, women can be nastier than men. Does sex really make a difference? Jan Howard Finder Daniel Dvorkin Bart Kemper Elizabeth Moon Perry Williams
- 15:00 MR13 3G760 **The Alien Face** What do we read as an alien? It seems we can best be spooked by what we recognize in terms of our knowledge of the human face. The SF artist can exploit that knowledge. Heather Spears
- 15:00 MR15 3G697 **Bioethics/Bioengineering** If science can change a species, how can we protect ourselves? Who will decide who gets to benefit? Susan M Smith Clein L Warren Douglas Kathleen Ann Goonan Norman Hartman
- 16:00 ConCourse 3H814 **Autograph Sessions** Greg Costikyan Leslie Gadallah Barry B Longyear

DAY 3 - SATURDAY SEPT 3/94 - continued

- 16:00 MR 1 3H745 **Chesley Awards** Reception and awards hosted by ASFA. Artist awards for artwork and artists. Open to all members of Canadian. Stu Hellingner
- 16:00 MR 2 3H281 **Psi Powers** A discussion on the various psi powers: what they are and how to use them. David M. Kushner Joyce Andrews Glenn Battis Norman Hartman Elizabeth Ann Scarborough Anne McCaffrey
- 16:00 MR 4 3H734 **Upcoming Movies Presentation** Movies may include Judge Dredd, Shelly's Frankenstein and Interview With The Vampire Len Wein Charles Lippincott
- 16:00 MR 5 3H837 **KaffeeKlatsch** Limited ADVANCE Registration - Inquire at Con Info Desk. Terry Garey Jeanne Robinson Spider Robinson Harry C Stubbs Gene Wolfe M Shayne Bell
- 16:00 MR 6 3H061 **Internet—New Applications & Directions** Is it real or is it InterNet? What else can be done online? Ben Best Glenn Hauman Jack C Haldeman II Malt Crawford Ellen Key Harris
- 16:00 MR 7 3H609 **First Fandom Annual Meeting** Annual business meeting, open to all Canadian members, followed by application for membership. D. H. Blair
- 16:00 MR 9 3H238 **Techniques in Acrylic Painting** Brush strokes, colors, tools... all the tips to make your own piece of art. How to make brick look like brick. Erin McKee
- 16:00 MR10 3H226 **Q&A with Jean Lorrh** This is the usual Lorrh/Lichtenburg presentation but Jacqueline can't attend this year. Jean will have info on both authors latest projects including Savage Empire, Sime/Gen and Star Trek novels. Jean Lorrh
- 16:00 MR12 3H168 **Genetic Engineering** If we can re-engineer flowers and vegetables, how long before Ronko markets the "Gene Master?" James Young Daniel Dvorkin Jeri Freedman Ian K Hagemann Susan M Smith
- 16:00 MR13 3H658 **Other Cultures in F&SF (Cultural Heritage and Myths)** How to use another culture's myths in your fiction. S. M. Stirling Sasha Miller K. D. Wentworth Mary Cannings Daniel Fresnot
- 16:00 MR14 3H020 **Research for Science Fiction Writers/Lecture** Why bother with research. How to start. When to end. Who to talk to. What pitfalls to avoid. How to take notes that really help. The info on how to get info. Billie Aul
- 16:00 MR15 3H066 **Editing Magazines & Anthologies** If you are an editor, what's the difference between magazines and anthologies? How far should an editor go to shape a story? Ellen Datlow Gardner Dozois Scott Edelman David G Hartwell Mike Resnick Charles C Ryan
- 17:00 ConCourse 3I815 **Autograph Sessions** Dawn Dunn Jack Dann Stanley Schmidt
- 17:00 MR 2 3I659 **Post-Cyberpunk** Where does the future take us now? Daniel L Marcus Bandit David Brin Maureen F McHugh Allen Steele
- 17:00 MR 6 3I216 **The Many Faces of Fandom** What are all these people doing? Is it as weird as it looks? Why do they all look alike? Mike Glyer Daniel Fresnot Mike Glicksohn Franklin Hummel George (Lan) Laskowski Alan Stewart
- 17:00 MR 9 3I050 **How to Stay Alive 'Til Your Big Break** Do you really need to eat after you submit your manuscript? Roger MacBride Allen Kevin J Anderson K.B. Bogen David Drake Janet Hetherington
- 17:00 MR10 3I774 **Towards a Language of Critical Games Analysis/Design** What is a good game? How can you tell a good game from a bad one? As game designers, we need a way to analyze games, to try to understand what works and what makes them interesting. And we need to invent a critical language to do this. Greg Costikyan
- 17:00 MR12 3I671 **Utopia: Who Wants to Live There?** The pros and cons of the Utopian society. Dr. Arlan Andrews Dr. Janice Bogstad Donald Kingsbury Frederick Andrew Lerner Jack Nimersheim
- 17:00 MR13 3I109 **The Art of ON SPEC** From the beautiful to the bizarre. Presented by Lynne Fahnestalk, art director of ON SPEC, the award-winning Canadian magazine of speculative writing. Lynne Taylor Fahnestalk
- 17:00 MR14 3I885 **Reading by Elisabeth Vonarburg** Elisabeth Vonarburg reads her own work Elisabeth Vonarburg
- 17:00 MR15 3I775 **Why "Manned" Space Flight?** Much of the confusion and indecision over the space program is because, we as a nation, have never decided WHY we are in space. This panel explores the definition and prioritization of these objectives, and their affect on the type and scope of space activities. SIGN UP by Saturday 12 noon in VIP Lounge of the Convention Centre. John Strickland Jr.

DAY 3 - SATURDAY SEPT 3/94 - continued

- 18:00 MR13 3J737 **Artemis Project Comercial Lunar Base** Everyone who wants to work on the Artemis Project commercial lunar base is invited to attend this organizational meeting! Open to all Conadian members. Gregory Bennett
- 20:00 HALL "B" **Hugo Award Ceremonies** The 41st Hugo Awards Ceremony's Master of Ceremonies ConAdian's Toastmaster, Barry Longyear. All ConAdian members are invited to attend to honour the Nominees on their special night.
- 21:00 MR 8 3M786 **Con Furence** Artist Jam. Art session/demos by artists. Artists are invited to perform work at the jam. Fans and artists may wander in to pickup tips or even commission art work. Rodney Stansfield
- 21:00 MR 9 3M113 **How to Manhandle your Friends & Have them Love It (Massage)** Workshop to provide some basic instruction in how to manually manipulate the hands, back, head, face and feet to achieve stress reduction and a nice pleasant feeling. Attendees participate by practicing on each other. Jan Howard finder
- 22:00 MR 1 3N273 **The End of the World** Every society has their legends of how the world will end. But what happens afterwards? Mary A Turzillo Sandra Morrese Charles Pellegrino Connie Willis Terry J. Jones
- 22:00 MR 2 3N135 **Ghosts** A discussion of ghosts in fact and fiction. Lee Barwood P. N. Elrod Jim Groat
- 22:30 RM2EFG **Rock Dance** After the Hugo awards join us at the Rock Dance sponsored by Warner Books who are celebrating their new science fiction line which debuts this August. Come meet authors, C.J. Cherryh, Kevin J. Anderson, Jane Fancher, David Feintuch and other....they'll give away prizes, free books and more!
- 23:00 MR12 3O310 **Vampire Book Tour** A bloodcurdling tour of vampire books lurking on bookstore shelves. Will concentrate more on the newer fiction, but will also discuss with the audience some not-to-be-missed classics. Beverley Richardson
- 24:00 MR 7 3P189 **Putting on a con** The do's and don's from those who have already built the wheel David Hayman Bill Farwa Cindy Huckle Val Ontell Henry Welsh Tom Veal

DAY 4 - SUNDAY SEPT 4/94

- 09:00 MR 8 4A747 **Aerobics** Exercise for the fanish masses. Come on, it's good for you! John Douglass
- 10:00 ConCourse 4B816 **Autograph Sessions** Phil Foglio Kaja Foglio David G Hartwell
- 10:00 MR 1 4B107 **How to get Artwork Published, Artists Going Pro** The difference between "fan" and "pro" art and how to place yourself in the market. George Barr Brad Foster Ric Meyers Michael Whelan
- 10:00 MR 2 4B241 **Magic Realism** A discussion on magic, supernatural beings, and the laws of conservation. Mary H Rosenblum Daniel L Marcus Maureen F McHugh Carrie Richerson
- 10:00 MR 4 4B161 **Military SF** How does military SF relate to the real military? Bart Kemper Timothy Lane Howard Scrimgeour Perry Williams
- 10:00 MR 5 4B838 **KaffeeKlatsch** Limited ADVANCE Registration - Inquire at Con Info Desk. Josepha Sherman Jonathan V. Post Briccio Barrientos Charles Pellegrino
- 10:00 MR 7 4B339 **Publishing on the Desktop** How desktop publishing can work for you. Roger MacBride Allen Glenn Hauman Arthur Kyle Jean Lorrah Julia Martin
- 10:00 MR 9 4B072 **Advances in Medicine, Genetics, Technology, Etc.** With all the advances made in recent history, is SF falling behind the curve? Jeri Freedman Maggie Flinn Karl Johanson S. M. Stirling John Strickland Jr.
- 10:00 MR12 4B742 **SFWA Meeting** The Science Fiction and Fantasy Writers of America is an organization founded to inform its membership about matters of professional interest to writers, to promote their general welfare, and to help them deal effectively with publishers, editors and anthologists. The business meeting is closed to the public. Gay Haldeman
- 10:00 MR13 4B788 **Electronic Fiction and Publishing** Hypertext demo with Eastgate Systems Kathryn Cramer
- 10:30 Fort Rouge Park 4B772 **Pagan Ritual** Not a sky clad rite. In other words, you MUST wear clothing to attend. Bill Avery
- 11:00 ConCourse 4C817 **Autograph Sessions** S. M. Stirling Maureen F McHugh
- 11:00 MR 1 4C409 **Future of Space Exploration** What has been happening since Apollo? How can we get to Mars and beyond? Hugh Gregory Gregory Bennett Gerald D. Nordley Henry Spencer David Stephenson Henry Vanderbilt

DAY 4 - SUNDAY SEPT 4/94 - continued

- 11:00 MR 2 4C386 **Use of Violence in SF** Violence seems to be a way of life now. How has SF encouraged its growth? L Warren Douglas Geoff Ryman Ron Sarti Jean-Louis Trudel Ann Tonsor Zeddies
- 11:00 MR 4 4C612 **Writing with Anne McCaffrey** Meet some writers who have worked in a universe that is known and loved by millions. Jody Lynn Nye Jack Cohen Elizabeth Moon Elizabeth Ann Scarborough
- 11:00 MR 7 4C778 **Cyberspace in Multi-User Dungeons** A demonstration of Virtual Reality MUDs and MOOs. Dr. Joseph Donatelli
- 11:00 MR 9 4C266 **Bioethics Considerations** A discussion of the ethics of bioengineering. Lois H Mangan Genny Dazzo Kathleen Ann Goonan Ross Pavlac J.D. Maynard
- 11:00 MR15 4C249 **How to Sell SF to General Readers as Literature** What's a general reader? What's literature? Possible ways to package SF in order to reach a broader market. Gerri Baller Janice M Eisen Patrick Nielsen Hayden
- 12:00 ConCourse 4D818 **Autograph Sessions** Nancy Kilpatrick Jack Nimersheim Geoff Ryman
- 12:00 MR 1 4D721 **WSFS Business Meeting, Second Main Session** The results of the 1997 Worldcon Site Selection will be formally announced at the beginning of today's meeting. Further debate on amendments to the WSFS Constitute, as well as reports from Worldcon committees, are expected today. All regular business is expected to conclude today, to be followed by Question Time, where you can grill representatives of future Worldcon Committees and Bid Committees. Kevin Standlee
- 12:00 MR 2 4D354 **The Meaning of Dark Fantasy** An exploration into the depths of dark fantasy. Daniel L Marcus K.B. Bogen Stephen Dedman Dawn Dunn P C Hodgell Caro Soles
- 12:00 MR 4 4D408 **Star Wars Novels** Star Wars has captured the hearts of millions. Come learn what is being done now and for the future. Kevin J Anderson Rebecca Moesta Anderson Janna Silverstein Kathy Tyers Tom Dupree
- 12:00 MR 5 4D839 **KaffeeKlatsch** Limited ADVANCE Registration - Inquire at Con Info Desk. Mike Resnick Lee Barwood Chris Rutkowski Shariann Lewitt Robert J. Sawyer
- 12:00 MR 7 4D320 **Reach for the Stars** Trivia Contest with Star Trek Regina Come and display your knowledge, test your skill, and win the day Hilary Ryan
- 12:00 MR 9 4D247 **What is REALLY Killing the Backlisting of Good Books** A discussion on the shelf-life of books and how to keep our favorites front and center in the buyer's mind. Joseph T Mayhew Tom Doherty Patrick Nielsen Hayden Robert Runte Shelly Shapiro
- 12:00 MR10 4D385 **Getting Your Stars Right the First Time** Green stars? The Sun going nova? Tau Ceti going supernova? Science fiction can often raise an astronomer's hackles. A review of the stars which do and do not exist, and how to intergrate astronomical assumptions into fiction. Jean-Louis Trudel
- 12:00 MR13 4D379 **The DreamTime Art of the Australian Aborigines** Native culture, myths and folklore. Stories about mythical creatures like the rainbow serpents tie in well with fantasy & SF themes. Charlene Taylor
- 12:00 MR14 4D886 **Reading by Harry Stubbs (Hal Clement)** Harry Stubbs (Hal Clement) reads from his own work. Harry C Stubbs
- 12:00 MR15 4D350 **One Language for the World?** The pros and cons of a worldwide language. Dr. Janice Bogstad Myra Cakan Joel Champetier Frederick Andrew Lerner Stanley Schmidt
- 13:00 ConCourse 4E819 **Autograph Sessions** Ellen Dallow Martha Soukup Donald Kingsbury
- 13:00 MR 2 4E441 **How We Deal With Death & Dying** This is something that we all will do at least once in our life, but how do we really feel about it. George Barr Barry B Longyear Lois H Mangan Connie Willis
- 13:00 MR 4 4E402 **Liar's Panel on How to Get Published** So you think you've tried every way possible to get your manuscript accepted... Gene Wolfe Joe Haldeman David G Hartwell John M. Landsberg Wil McCarthy Roger E. Moore
- 13:00 MR 6 4E776 **GnuGnome/Gnome Press Presentation** During the forties and fifties, Dave Kyle's original Gnome Press published first novels by many science fiction legends, including Isaac Asimov and Arthur C. Clarke. GnuGnome Press will attempt to follow in the tradition, publishing limited edition hardcovers devoted to quality science fiction. Ralph Schiano David Kyle Arthur Kyle
- 13:00 MR 9 4E400 **The Library of the World at Your Desk** Explore the world of electronic libraries with those who have already gone before. Michael J Ward Ben Best Billie Aul Marty Helgesen Ken Meltner
- 13:00 MR10 4E887 **Reading by Jack L. Chalker** Jack L. Chalker reads his own work. Jack L Chalker

DAY 4 - SUNDAY SEPT 4/94 - continued

- 13:00 MR12 4E626 **Dragonriders of Pern Fan Clubs** Opportunity for Dragonrider/Pern fan clubs to meet and discuss fan club interests. Magi Shepley
- 13:00 MR13 4E715 **The Klingon Empire on 5 Credits A Day!** Beware Terrans, the Klingon Empire is taking over Kanada and the rest of the planet Earth. Hear about the Kanadian Klingon Empire and how you will be conquered/assimilated. A discussion of Klingon culture, rituals, language, and other aspects of this growing part of "trek" fandom here in Kanada. Bernard Reischl
- 13:00 MR15 4E077 **Non-Monogamous or Non-Heterosexual Relationships** The Moral Majority abhors them; the vast majority is silent. Is it the purpose of SF to de-demonize these types of relationships? Genny Dazzo Stephen Dedman Alexandra Honigsberg George R R Martin
- 14:00 ConCourse 4F820 **Autograph Sessions** Josepha Sherman Bridget McKenna
- 14:00 MR 1 4F242 **Themes of Abuse** Psychological abuse as well as physical abuse is not new. Is fiction another tool for writers and readers to work through and deal with a serious issue? Barry B Longyear Ctein David Drake Kathei Logue William R. Lund
- 14:00 MR 2 4F370 **Gender Roles** How has society shaped our stereotypes and can technology change them. George Barr Cynthia Felice Judith Hayman Mary A Turzillo S. M. Stirling
- 14:00 MR 4 4F362 **The State of SF TV/Movies** How TV and the movies treat Science Fiction. Ric Meyers John L Flynn Stan Hyde Perry Mark Stratyckuk
- 14:00 MR 5 4F840 **KaffeeKlatsch** Limited ADVANCE Registration - Inquire at Con Info Desk. Judith Merrill jan howard finder Allen Steele
- 14:00 MR 6 4F779 **Aliens of the 90's** Who are they? What are they? Alien trends and predicions. Dr. Joseph Donatelli
- 14:00 MR 7 4F275 **Breaking into the Professional Markets** Get some tips from people who have been there. How did they get their first break? Ashley D Grayson Steve Fahnestalk Guy Gavriel Kay Terry Erdmann Betsy Mitchell
- 14:00 MR 9 4F263 **Future of Education** Will education meet the changing requirements of the 21st century? John Hertz Ann L. Chancellor Kathleen Ann Goonan Bradford Lyau Lindalee Stuckey
- 14:00 MR10 4F410 **Importance/Ethics of Terraforming Other Planets** How can we justify this work to the universe? Roger MacBride Allen Frederick Andrew Lerner Stanley Schmidt John Strickland Jr.
- 14:00 MR12 4F333 **SF Vs. Fantasy** Is SF a subset of Fantasy...Or is Fantasy a subset of SF...Or are they both opposite sides of the same coin? J.R. Dunn Dave Duncan Claire Eddy Alexis A Gilliland Jennifer Hershey
- 14:00 MR13 4F727 **Breaking into Screenwriting** Gillian Horvath, who broke into screenwriting with the Quantum Leap episode "Promised Land", shares some of the do's and don'ts of the town where, as William Goldman put it, Nobody Knows Anything. Gillian Horvath
- 14:00 MR15 4F888 **Reading by Jean-Louis Trudel** Jean-Louis Trudel reads his own work. Jean-Louis Trudel
- 15:00 ConCourse 4G821 **Autograph Sessions** Elizabeth Ann Scarborough
- 15:00 MR 1 4G319 **Does our Culture Have a Myth System?** Explore how myths, both ancient and modern, are shaping our culture. Claire Eddy Laura Frankos Janet Hetherington David Honigsberg Julia Martin
- 15:00 MR 2 4G617 **Let's Drive A Stake Through The Romantic Vampire** What to do when your character has fallen in love with a perfectly good symbol of evil. Janeen Webb Stephanie Bedwell-Grime Beverley Richardson Nancy Kilpatrick
- 15:00 MR 4 4G395 **SF and Social Responsibility of Writers** Of course we are responsible to our society. The question is: are we doing enough? Sandra Morrese Stephen Burns L Warren Douglas Dawn Dunn Ian K Hagemann Amy Thomson Anne McCaffrey
- 15:00 MR 7 4G010 **Monster Trivia Quiz/Hosting** This your opportunity to test your knowledge of those dark creatures out of man's imagination. Three rounds of monster trivia. Winners will receive monster prizes. Hosted by the Monster Club. Compete as teams or individuals, open to all. Raul Andreu
- 15:00 MR10 4G889 **Reading by Jean Lorrha** Jean Lorrha reads her own work Jean Lorrha
- 15:00 MR12 4G282 **Small Press Publishing** A small press shop vs. the big monsters of the industry. Who can serve you better? Michael J Ward Jim Groat Deryll Murphy Jack Nimersheim Ralph Schiano Gene Wolfe Andrew Porter

DAY 4 - SUNDAY SEPT 4/94 - continued

- 15:00 MR13 4G299 **Jurassic Park: The Science Behind the Fiction** From the scientist who invented the dinosaur cloning recipe that became Jurassic Park....an in depth look into the science behind the fiction. Charles Pellegrino
- 15:00 MR15 4G286 **Interstellar Propulsion with Known Physics** How science can help us explore outer space. Geoffrey A Landis Howard Davidson Karl Johanson Waldemar Kuming Gerald D. Nordley
- 16:00 ConCourse 4H822 **Autograph Sessions** Connie Willis Dr. Arlan Andrews Mike Resnick
- 16:00 MR 1 4H284 **Politics in SF** Literature has always been a medium for expressing and critiquing politics. How can this help or hinder your story? Alexis A Gilliland J.R. Dunn Janice M Eisen Astrid Julian Maureen F McHugh
- 16:00 MR 2 4H090 **Medical Situations in Fiction** Today's reader is too sophisticated to allow magic in medicine. So how can you create a believable medical scenario? Judy Lazar Joel Champetier Lois H Mangan Elizabeth Moon Howard Scrimgeour
- 16:00 MR 4 4H280 **SF on Television** What are the pro's and con's of a mass audience tool like TV? After all, more people watch TV than read books. Gillian Horvath John L Flynn William R. Lund George R R Martin Craig Miller
- 16:00 MR 5 4H841 **KaffeeKlatsch** Limited ADVANCE Registration - Inquire at Con Info Desk. Kevin J Anderson Betsy Mitchell
- 16:00 MR 7 4H330 **Creating an Internally Consistent Religion** Every culture must have some sort of religion to hold it together, but can it be as easy as the "Great Polalo" theory? Harry Turtledove William "Wolf" Foss John Hertz Robert Sawyer David Wixon
- 16:00 MR 9 4H749 **Japanese SF** The literature of Science Fiction as it appears in Japan. Masamichi Osako Takumi Shibano Miho Hiramoto Anthony Bryant
- 16:00 MR10 4H890 **Reading by Barry B. Longyear** Barry B. Longyear reads his own work. Barry B Longyear
- 16:00 MR12 4H716 **The Klingon Dating Game-Hosted by KAG/Kanada** The Dating Game as you've never seen it. Our Klingon, and other-worldly, contestants compete against one another for the sheer fun of it. Who knows—you, or they, may get lucky with an "out of this world" gal or guy! Bernard Reischl
- 16:00 MR13 4H759 **How I Create a Book Cover Illustration** It takes more than a half-naked lady to do the job these days. How to do justice to the book within and still be artistic and creative. Michael Whelan
- 16:00 MR15 4H735 **1998 and Beyond Worldcon Bid Presentations** Meet the people who want to host a worldcon and are bidding for years beyond 1997. Mike Glyer
- 17:00 ConCourse 4I823 **Autograph Sessions** Lee Barwood Caro Soles
- 17:00 MR 1 4I082 **Aging Gracefully** In our youth we fought against "The Establishment," and now we are Them. How does this define society? Marjii Eilers Clifton Amsbury Leslie Gadallah George (Lan) Laskowski Carrie Richerson
- 17:00 MR 2 4I309 **Aliens in SF** Hollywood has given us many examples of life from another planet, but would we know one if it bit us on the nose? Jack Cohen Stan Hyde John M. Landsberg Anne McCaffrey Wil McCarthy Beth Meacham
- 17:00 MR 6 4I004 **Writing for the young adult market** Is horror taking over? How is it different from adult? Which subject are appropriate or not? Carol Matas Josepha Sherman Lindalee Stuckey
- 17:00 MR 9 4I625 **Convention Burnout** Do you feel like the only reason you came was to collect another badge for your wall? Here's some help on removing or avoiding the problem. Kathei Logue David Stein, DI Perriane Lurie Michael Wallis
- 17:00 MR 10 4I781 **The Physics of Star Trek** A discussion of matter/antimatter conversion, faster-than-light travel and subspace communication in the Star Trek Universe. Dr. Art Stinner Dr. Kumar Sharma
- 17:00 MR12 4I891 **Reading by Spider and Jeanne Robinson** Jeanne and Spider Robinson read their own work. Jeanne Robinson Spider Robinson
- 17:00 MR13 4I769 **Comet Crash!** Video, slides, discussion, and more of the Great Comet Crash! Terry J. Jones David Stephenson Hugh Gregory John Strickland Jr.
- 18:00 MR13 4B738 **Artemis Project Team Meeting** Organization Meeting on the comerial lunar base Gregory Bennett
- 20:00 HALL "B" **Masquerade** Doors open at 7:30 pm The Masquerade is always the most spectacular venue at Worldcon and this year will be no exception.

DAY 4 - SUNDAY SEPT 4/94 - continued

20:00 MR12 4L708 **Calling All Mad Scientists: Population Heading to 10 Billion!** The dangers of overpopulation and what we could do about it. Astrid Julian Leslie Gadallah Karl Johanson David Stephenson David Wixon

DAY 5 - MONDAY SEPT 5/94

10:00 MR 1 5B027 **The Fiction of Anne McAffrey/Academic Papers** A presentation of critical papers dealing with the works of Anne McAffrey. Jody Lynn Nye Dr. Elizabeth Anne Hull

10:00 MR 2 5B420 **Defining SF** Is there room for any clear definitions and separation of genres in post-modernism? Catherine Donahue Girczyc Miho Hiramoto Frederik Pohl Takumi Shibano Ariane Von Orlow

10:00 MR 9 5B392 **Religion & SF** Why are so many SF writers loathe to include religion if it is such an important aspect of our culture? Anthony Bryant Marty Helgesen Joseph T Mayhew Wil McCarthy Dave Wolverton

10:00 MR10 5B406 **The Special Appeal of Short Stories in SF&F** Discover the unique and special properties of short stories. Scott Edelman Richard Chwedyk Gardner Dozois Derryl Murphy Carrie Richerson

10:00 MR13 5B146 **Apollo: 25 Years Later** One small step for this man, one giant leap for mankind. M Shayne Bell Hugh Gregory Andre Lieven Henry Spencer Charles Sheffield

11:00 MR 1 5C067 **Where Field (SF, Fantasy and Horror) is Going** Is there still room for innovation in future SF? How can the old classics be published in today's market? Patrick Nielsen Hayden Shelly Shapiro David Wixon

11:00 MR 2 5C142 **Cyberculture** Cyber-knowledge: Is it good, is it bad, and how can the government suppress it? Dr. Janice Bogstad Bandit Jordin Kare Ashley D Grayson Jonathan V. Post

11:00 MR 7 5C359 **The Geography of Space** Space is not just a featureless emptiness. It has its own geography: useful & useless areas, important resources and dangers. Henry Spencer

11:00 MR 9 5C593 **Archeology of the Future** Digging up the future! What will future generations believe about us based on our tools and possessions? jan howard finder Len Wein

11:00 MR13 5C125 **Collecting SF Film & Toy Memorabilia** Designed to attract the novice collector, as well as inform the hardcore memorabilist. John L Flynn

11:00 MR15 5C763 **SF Jeopardy!** What game is so good that we need to have it twice. Final session. Doug Kemp

12:00 MR 1 5D220 **Scientific Accuracy in SF** How accurate must a writer be when impossibilities such as FTL and time travel are accepted? Howard Davidson George Flentke Edmund R. Meskys Susan M Smith

DAY 5 - MONDAY SEPT 5/94 - continued

12:00 MR 2 5D499 **Safe Sex in SF: A Writer's Obligation?** How can it change for the future? Is "The Demolition Man" the shape of things to come? Paula Johanson Billie Aul Ctein Sally McBride

12:00 MR 7 5D703 **What Fans Would Like to See at NASFiC (Atlanta) in 1995** The hosts from Atlanta would like to hear from you & answer questions. Edward Kramer

12:00 MR 9 5D115 **Surviving Your First Masquerade** The Do's and Don'ts of masquerading for the novice. Marjii Eilers Pierre E Peltinger Jr David W Clark Ann L. Chancellor jan howard finder Zelda Gilbert Sandra G Peltinger

12:00 MR10 5D423 **How to Research in Historical Matters for Story** How and where to perform research for historical accuracy. Jody Lynn Nye Jack Dann Sasha Miller

12:00 MR13 5D325 **The Geology of Middle Earth** Experience Tolkien's World through this special slide show event. Dr. William Sarjeant

12:00 MR15 5D523 **What Is and Isn't Filk** Filk, Folk, Funny songs... What makes Filk unique? Glenn Simser Andrea Yeomans David Hayman Judith Hayman Howard Scrimgeour Mary Ellen Wessels

12:00 WEST 5D758 **Mark Protection Committee Meeting** The WSFS Mark Protection Committee administers the service marks on "Worldcon", "Hugo Awards", and the other WSFS marks. This committee meeting is open to all members of ConAdian, seating permitting. Kevin Standlee

13:00 HALL "B" **Closing Ceremonies** Please join with us in saying goodbye to the 52nd. Worldcon and welcome to Intersection, the 53rd.

13:00 MR 1 5E228 **Getting the Medicine/Biology Right** A discussion on where, how and why you should research. Perrienne Lurie Genny Dazzo George Flentke Howard Scrimgeour

13:00 MR 2 5E129 **Time Travel Which Alters History** How would we change the present if could change the past. Robert Sawyer Frederik Pohl S. M. Stirling Harry C Stubbs Ariane Von Orlow

13:00 MR 9 5E126 **Teaching Science Fiction at the University Level** How SF is used to influence the values and behaviors of another generation. Zelda Gilbert Jeremy Bloom

14:00 MR 1 5F424 **Robert A. Heinlein** He made a profound impact on more people than most writers will ever reach. Learn more about the man and his life. Keith G. Kato Dr. Elizabeth Anne Hull

14:00 MR 2 5F267 **Adapting Real History/Anthropology Backgrounds** How to make reality unreal enough for fantasy. Anthony Bryant Josepha Sherman S. M. Stirling Mary A Turzillo

15:00 MR 1 5G610 **Winnipeg Worldcon Convention Critique, Gripe Session** Hey, we're open to compliments too! Let us know what you thought of the 1994 Worldcon...we're taking note for future cons.

PROGRAM PARTICIPANT BIOGRAPHIES

(SEE PAGE 16 FOR PROGRAM CODE DEFINITIONS)

GAIL S. ABEND Tech Editor, and quality assurance expert for TRW. GAIL S. ABEND is on panels 2H677, and 2I352.

BARRY ADLER and Sheila Adler are administrators for the Science Fiction Model Builders' Association and owners of The New Frontier. BARRY ADLER hosts events 2C729, and 3B730.

SHEILA ADLER and Barry Adler are administrators for the Science Fiction Model Builders' Association and owners of The New Frontier. SHEILA ADLER hosts events 2C729, and 3B730.

ROGER MACBRIDE ALLEN has published various short fiction and non fiction articles. His forthcoming novels are: The Shattered Sphere and Inferno. ROGER MACBRIDE ALLEN is on panels 2G033, 3I050, 4B339, 4F410, autograph session 3E811, and kaffeeklatsch 3B834.

SUSAN ALLISON is in charge of ACE Science Fiction for Berkley Publishing Group. SUSAN ALLISON is on panel 3B224.

CLIFTON AMSBURY, an anthropologist, has been a fan since 1928. CLIFTON AMSBURY is on panels 2F696, 2O088, and 4I082

KEVIN ANDERSON is a writer and technical editor. Kevin has sold 25 novels including the new Star Wars trilogy Jedi Search. KEVIN ANDERSON is on panels 2D035, 3I050, 4D408, autograph session 2H806 and kaffeeklatsch 4H841.

REBECCA MOESTA (ANDERSON) is a technical writer and editor. She has a forthcoming short story in Star Wars: Tales from the Mos Eisley Cantina. REBECCA MOESTA (ANDERSON) is on panels 2B007, 2N604 and 4D408

SUNNIE ANDREU is a bookstore owner, and expert in Tarot. SUNNIE ANDREU is conducting panel 1L009.

RAUL ANDREU is a book store owner and a founding member of the Monsters Club (1993). RAUL ANDREU is hosting event 4G010.

DR. ARLAN ANDREWS, SR. SF author, member of SFWA, manager at Sandia National Laboratory, formerly with the White House Science Office and White Sands Missile Range. DR. ARLAN ANDREWS, SR is on panels 1I236, 2F561, 2H011, 3F269, 3I671, and autographs session 4H822.

JOYCE S. ANDREWS has been a paranormal phenomena test subject, and has used her abilities in many kinds of investigations: hauntings, crop circles, missing persons, healings, and archaeological sites. JOYCE S. ANDREWS is on panel 3H281.

BILLIE AUL is a sentient, animate information negotiator and provider at the New York State Library. BILLIE AUL is on panels 2C022, 3H020, 4E400, and 5D499.

IAN BALLANTINE No bio. information available. IAN BALLANTINE is on panels 2B007, and 3B224.

BETTY BALLANTINE No bio. information available. BETTY BALLANTINE is on panels 2B007, and 3B224.

GERRI BALTER is a writer and active fan with many varied interests including American Indian studies. GERRI BALTER is on panels 2G459, 3C163, and 4C249.

BANDIT is a computer consultant with particular understanding of virtual reality applications in medicine. BANDIT is on panels 2E639, 3I659, and 5C142.

ALAN BARCLAY is a young writer whose interests include anthropology, history, astronomy and physics. ALAN BARCLAY is on kaffeeklatsch 2B800.

GEORGE BARR is Artist Guest of Honour, see program book for bio. GEORGE BARR is on panels 3E724, 4B107, 4E441, 4F370, and autograph session 2D831.

BRICCIO BARRIENTOS is an accountant/analyst in the federal government; obviously he is highly experienced in the field of humorous fiction. BRICCIO BARRIENTOS is on panels 2D035, 3F209, and kaffeeklatsch 4B838.

LEE BARWOOD author, 1990 winner of the Gryphon Award. She is a member of SFWA, the Mystery Writers of America, and the Authors Guild. LEE BARWOOD is on panels 2D621, 2O632, 3E124, 3N135, autograph session 4I823, and kaffeeklatsch 4D839.

GLENN BATTIS works with the Pentium processor at Intel; he's most interested in television SF. GLENN BATTIS is on panels 2G687, 3F178, and 3H281.

STEPHANIE BEDWELL GRIME has done many things, from copywriting to medical photography; some current enterprises are filking, writing and editing fanzines. STEPHANIE BEDWELL GRIME is on panels 1O075, 2H049, 2O632, and 4G617.

M. SHAYNE BELL, an anthologist and novelist, has been poetry editor at Sunstone magazine for five years. M. SHAYNE BELL is on panels 2B007, 2G024, 3F209, 5B146, and autograph session 3C809, and kaffeeklatsch 3H837.

GREGORY R. BENNETT manages EVA development for NASA at the Johnson Space Center; he also has published three SF stories and worked on many conventions. GREGORY BENNETT is on panels 3B737, 4B738, 4C409, and autograph session 3G813.

BEN BEST, an immortalist with degrees in Physics and computer science, is President of the Cryonics Society of Canada. BEN BEST is on panels 3H061, and 4E400.

JOSHUA BILMES is literary agent for Elizabeth Moon, Tanya Huff, Bill Baldwin and others. JOSHUA BILMES is on panels 2O632, and 3D048.

D. H. BLAIR No biographical information available. D. H. BLAIR hosts event 3H609.

JEREMY BLOOM is a professional journalist whose credits include: Parenting, The New York Times, and Playboy. His subjects include SF, cyberspace and online material. JEREMY BLOOM is on panels 1H006, and 5E126.

K.B. BOGEN has been a writer since she was seven; her first book, Go Quest, Young Man, will be out in September. K. B. BOGEN is 3I050, and 4D354.

DR. JANICE BOGSTAD University of Wisconsin, Eau Claire Collection Development Librarian. DR. JANICE BOGSTAD is on panels 1G134, 3I671, 4D350, and 5C142.

ANNA BOUDREAU president of TARDIS 204; publisher/creator of "Badlands" British/Canadian fanzine. ANNA BOUDREAU is hosting event 2G713.

KENT BREWSTER writer of "The Dream Pirate's Tale", and "Some Notes on the Practical Applications of Fear", is a SFWA member.

DAVID BRIN No biographical information available. DAVID BRIN is on panels 2E639, 3I659, and 4F410.

ANTHONY BRYANT has written several books on Japanese history, and translated Japanese SF. ANTHONY BRYANT is on panels 1I633, 2C197, 3G031, 4H749, 5B392, and 5F267.

GINJER BUCHANAN is Executive Editor of "SF and Fantasy". GINJER BUCHANAN is on panels 1M015, 2H144, 2L629, and kaffeeklatsch 3B834.

STEPHEN L. BURNS, a self described "demented generalist" and con virgin, has written for Analog and other magazines, and been anthologized in Sword and Sorceress, Spells of Wonder, and The Year's Best Fantasy. STEPHEN L. BURNS is on panels 2E458, 2F574, and 4G395.

ROGER BURTON WEST No biographical information available. ROGER BURTON WEST is on panels 1I633, 2D552, 2I352, and 3F211.

MYRA CAKAN is a freelance writer and movie critic who has published short science fiction and horror stories in German anthologies and magazines. MYRA CAKAN is on panels 1H051, 2F047, 2H049, 3E098 and 4D350.

MARY CANNINGS has been library technician of the Merril Collection of Science Fiction, Speculation and Fantasy since 1990. MARY CANNINGS is on panels 3D657, and 3H658.

SUSAN CASPER has published short fiction in Asimov's Fantasy and Science Fiction and Playboy. SUSAN CASPER is on panels 2F574, and 3F269.

JACK CHALKER is a four time Hugo nominee, who has written over 40 novels. JACK CHALKER is on panels 1H615, 2G033, 3E124, 4E887, autograph session 2D802, and kaffeeklatsch 3F836.

JOEL CHAMPETIER author of books and short stories: "La Memoire du Lac", "Le Jour de Trop". JOEL CHAMPETIER is on panels 3D106, 4D350, and 4H090.

ANN LAYMAN CHANCELLOR is a professor of stage costume design and execution with a remarkable depth of knowledge of fantasy, folklore and mythic motifs. ANN LAYMAN CHANCELLOR is on panels 3D657, 4F263, and 5D115.

ROBERT CHARETTE is a graphic artist. His hobbies include: medieval artifact reconstruction, and living history re enactments. ROBERT CHARETTE is on panels 2G687, and 3D048.

RICHARD CHEDWYK is a writer of SF with stories published in "Amazing", and "Space and Time". RICHARD CHEDWYK is on panels 1H006, 2E458, 3G328, and 5B406.

C.J. CHERRYH has written over fifty books and has won three Hugos (so far!); she is also a filker and beautiful artist's model for her brother, David Cherry. C. J. CHERRYH is scheduled for autograph session 3F812.

DAVID W. CLARK chair of ConFrancisco, Dave has been active for many years in Northern California fandom. He has also had photographs published in LOCUS. DAVID W. CLARK is on panels 1F516, 3C163, and 5D115.

HAL CLEMENT see HARRY C. STUBBS

CAROLYN CLINK has published genre poetry in "ON SPEC", "Tesseract 4", "Northern Frights I & II" and "Starline". CAROLYN CLINK is on panel 1H006.

MARTIN CLUTTON BROCK combines a talent for acting with his knowledge of astronomy; in personae as Kepler, Copernicus, etc. he explains the pivotal discoveries of earth and space. DR. MARTIN CLUTTON BROCK is presenting 2F777.

DR. JACK COHEN consultant to sf authors (Anne McCaffrey, David Gerrold, Larry Niven, Terry Pratchett, and others) on designing alien creatures and ecologies. DR. JACK COHEN is on panels 2M722, 4C612, and 4I309.

GREG COSTIKYAN writer of By the Sword, and Another Day, Another Dragon from TOR Books. GREG COSTIKYAN is on panels 1H615, 2I352, 2L629, 3I774, autograph session 3H814, and kaffeeklatsch 3D835.

MAIA COWAN technical editor, writer of articles and manuals, veteran conrunner. MAIA COWAN is on panels 1H615, 1I017, 2D014, 2F561, and 3F178.

KATHRYN CRAMER author, winner of the World Fantasy Award for The Architecture of Fear (1988). KATHRYN CRAMER is on panels 1G002, 2C170, 2M622, 4B788, and autograph session 2E803.

MATT CRAWFORD works on computer networks at FermiLab. Has written articles for "Astrophysics Journal", and "Physical Review". MATT CRAWFORD is on panel 3H061.

CTEIN photographer and fan. CTEIN is on panels 3C062, 3G697, 4F242, and 5D499.

JACK DANN is the critically acclaimed author of Junction, Starhiker, The Man Who Melted and other works of science fiction, fantasy and history. JACK DANN is on panels 2E656, 5D423, autograph session 3I815, and kaffeeklatsch 3F836.

ELLEN DATLOW fiction editor at OMNI since 1981 and noted anthologist, has encouraged and developed many of today's best new writers. ELLEN DATLOW is on panels 2D035, 2H144, 3H066, and autograph session 4E819.

HOWARD DAVIDSON is a doctor of physics, senior scientist at Sun Microsystems, and self described "crackpot inventor." HOWARD DAVIDSON is on panels 4G286, and 5D220.

GENNY DAZZO is a doctor of theoretical chemistry, authority on advanced computer and management skills, and enthusiastic fan. GENNY DAZZO is on panels 4C266, 4E077, and 5E228.

STEPHEN DEDMAN is an author, creator of gaming worlds and adventures, actor, teacher, and used dinosaur salesman. STEPHEN DEDMAN is on panels 1O075, 3G328, 4D354, and 4E077.

TOM DOHERTY is founder and president of TOR Books. TOM DOHERTY is on panels 3B224, and 4D247.

DR. JOSEPH DONATELLI is the man with the news about MUDs & MOOs. DR. JOSEPH DONATELLI presents 4C778, and 4F779.

L. WARREN DOUGLAS is the author of A Plague Of Change, Bright Islands In A Dark Sea, and Cannon's Orb. L. WARREN DOUGLAS is on panels 2B007, 3G697, 4C386, and 4G395.

JOHN DOUGLASS is a visual and kinesthetic artist and an authority on aerobics and computer programming. JOHN DOUGLASS conducts aerobics classes 2A080, 3A746, and 4A747.

GARDNER DOZOIS No biographical information available. GARDNER DOZOIS is on panels 3E053, 3H066, and 5B406.

DAVID DRAKE was a lawyer, a busdriver, and an interrogator in SE Asia before becoming a full time writer. DAVID DRAKE is on panels 2G033, 3E124, 3I050, and 4F242.

DAVE DUNCAN is an award winning author of fantasy and science fiction whose works include the saga "A Handful of Men" and West of January. DAVE DUNCAN is on panels 2G033, and 4F333.

DAWN DUNN has been writing professionally for three years. Her work has appeared in Deathport, Love Potions, and Crazy Akhbar II. DAWN DUNN is on panels 1O075, 2M622, 4D354, 4G395, and autograph session 3I815.

J.R. DUNN's work has appeared in Amazing, Omni, and Asimov's. His first novel, This Side of Judgment, was published this summer. J.R. DUNN is on panels 2I563, 2O088, 4F333, and 4H284.

TOM DUPREE, a senior editor at Bantam Spectra Books spearheads their Star Wars program, as well as editing Bruce Sterling, Dan Simmons and others. He is the editor of the bestselling Jedi Academy Trilogy. TOM DUPREE is on panel 2G728, and 4D408.

DANIEL DVORKIN, co author of The Captain's Honor, a ST:TNG novel, is a USAF medic on active duty at Minot AFB. DANIEL DVORKIN is on panels 2O632, 2P091, 3G272, and 3H168.

DONALD E. EASTLAKE III Boskone, Noreascon, ARISIA, Boston '98, and Chair of WSFS Business Meetings.

JILL EASTLAKE ... for 25 years the Eastlake's ingenuity and hard work have fostered conventions and fandom. JILL EASTLAKE is on panel 3B093, and 3F178.

CLAIRE EDDY an editor for TOR Books with a degree in medieval history, helps her authors create authentic background for fantasy adventures. CLAIRE EDDY is on panels 2D621, 2G687, 4F333, and 4G319.

SCOTT EDELMAN has written for comics, television, and many magazines. He is the founding editor of Science Fiction Age. SCOTT EDELMAN is on panels 2H144, 3H066, 5B406, and autograph 3C809.

JANICE EISEN is a book reviewer and associate editor at Aboriginal SF magazine. JANICE EISEN is on panels 2G687, 3G031, 4C249, and 4H284.

MARJIL ELLERS, costumer extraordinaire, holds the first Lifetime Award for Service to Costuming given by the International Costumers Guild. MARJIL ELLERS is on panels 2D103, 3D106, 3F137, 4I082, and 5D115.

P.N. ELROD is the author of the six book Vampire Files series, I, Strahd, and the Red Death Historical Vampire series. P.N. ELROD is on panel 3N135.

LYNNE TAYLOR FAHNESTALK Art Director of ON SPEC, the multi award winning Canadian magazine of speculative writing. LYNNE TAYLOR FAHNESTALK presents panel 3I109.

STEVE FAHNESTALK has written for Amazing, Rat Tales, Rat Tales II, and Pulphouse Magazine. STEVE FAHNESTALK is on panels 3E098, and 4F275.

BILL FARINA No biographical information available. BILL FARINA is on panel 1F516, and 3P189.

MOSHE FEDER Military Book Club editor, and a book review columnist for ASIMOV's . MOSHE FEDER is on panels 1G002, and 2L629.

DAVID FEINTUCH worked as an attorney, photographer, and antiques dealer before becoming a writer; the first volume of his Nick Seafort saga will be out in November. DAVID FEINTUCH is on panel 2B007.

CYNTHIA FELICE Clarion Workshop graduate, her novels include Godsfire. Cynthia is a Campbell Award nominee. CYNTHIA FELICE is on panels 2G024, 4F370 and kaffeeklatsch 3F836.

jan howard finder Wombal power; space access; toastmaster prime. Backrubs a specialty. jan howard finder is on panels 1F516, 3G272, 3M113, 5C593, 5D115, and kaffeeklatsch 4F840.

GEORGE FLENTKE has a PhD in biochemistry. He is currently a scientist in the Department of Pharmacology at the University of Wisconsin, and conducts research on targeted drug design. GEORGE FLENTKE is on panels 2B520, 2I736, 5D220, and 5E228.

MAGGIE FLINN is both a practising physician (a Fellow in Rheumatology) and an author whose work has appeared in Asimov's and Omni. MAGGIE FLINN is on panel 4B072.

JOHN L. FLYNN is a writer and a professor of literature, specializing in science fiction, at Towson State University. He is a SFWA member, writer of six books on SF, horror, and Hollywood. JOHN L. FLYNN is on panels 4F362, 4H280 and 5C125.

KAJA FOGGIO is an artist and costumer with a particular interest in Greek and Norse mythology. KAJA FOGGIO is on panels 2F574, 2N604, and autograph session 4B816.

PHIL FOGGIO is a science fiction and fantasy artist whose work has been featured by many books and magazines. PHIL FOGGIO is on panels 2F574, 2N604, and autograph session 4B816.

WILLIAM "WOLF" FOSS is a professional safety and disaster consultant, a Renaissance Faire actor, a master story-teller, and a brewer. WILLIAM "WOLF" FOSS is on panels 2I736, 4H330, and kaffeeklatsch 3D835.

RICK FOSS is a travel agent to much of fandom, and an amateur brewer. RICK FOSS is on panels 2I736, and 3B193.

ADRIENNE FOSTER is a writer with an exceptional interest in ghosts and Elizabethan and Regency history. ADRIENNE FOSTER is on panels 1G134, and 3G031.

BRAD W. FOSTER, illustrator, cartoonist, and writer, has won four previous Hugos and is nominated again this year. BRAD W. FOSTER is on panel 4B107.

LAURA FRANKOS has SF&F published in Analog: The Anthology, Alien Pregnant By Elvis, and forthcoming in Orphans of the Night. LAURA FRANKOS is on panels 1H006, 2C022, 2I044, and 4G319.

JERI FREEDMAN, aka Ellen Foxe, who has published several science fiction stories and plays, is currently employed as a product manager for an analytical chemistry company. JERI FREEDMAN is on panels 2H227, 3H168, and 4B072.

DANIEL FRESNOT was born in Paris, but moved to Brazil at the age of 10. He has published a short story collection, poetry books, and a children's book. His SF works include several short stories and a post apocalypse novel set in Brazil. DANIEL FRESNOT is on panels 2G687, 2I563, 3H658, and 3I216.

ELLEN FOXE see JERI FREEDMAN

LESLIE GADALLAH, a writer and chemist, has published many works, both technical and fictional. LESLIE GADALLAH is on panels 2H677, 3C062, 4I082, 4L708, and autograph session 3H814.

TERRY GAREY is the editor of Time Frames and other poetry anthologies. TERRY GAREY is on panel 2D872, and kaffeeklatsch 3H837.

MARC GARNEAU is the first Canadian Astronaut to rocket into space. He is currently undergoing specialized astronaut training at NASA. MARC GARNEAU presents 3E731.

ZELDA GILBERT a doctor of psychology and Dean of Arts and Sciences at Woodbury University, is an innovative educator who is also a skilled costumer. ZELDA GILBERT is on panels 5D115, and 5E126.

ALEXIS GILLIAND Hugo winning cartoonist and writer whose works include three books of cartoons and seven novels, has been reading SF since 1944. ALEXIS GILLIAND is on panels 2H331, 4F333, and 4H284.

CATHERINE DONAHUE GIRCYC, who has written several award winning plays and has been involved in many areas of film and theatre production, is also a freelance journalist and poet. CATHERINE DONAHUE GIRCYC is on panel 5B420.

BRETT GLASS is a professional musician. BRETT GLASS is on panel 2E639.

MARK GLASSER agent and collator for APA-NYU. MARK GLASSER is hosting event 2F680.

MIKE GLICKSOHN, still Fannish after all these years. MIKE GLICKSOHN is on panel 3I216

MIKE GLYER O. E. of renowned 'zine FILE 770. MIKE GLYER is on panels 1H640, 3I216, and 4H735.

KATHLEEN ANN GOONAN is a writer and reviewer whose work has appeared in many major SF magazines. KATHLEEN ANN GOONAN is on panels 2F561, 3G697, 4C266, and 4F263.

GLENN GRANT, writer, editor, and graphic artist, is the founder and editor in chief of Edge Detector, a SF magazine, and the SF book reviewer for the

Montreal Gazette. GLENN GRANT is on panels 1M015, 2D014, 2E327, and 3C222.

ASHLEY GRAYSON is the agent for many best selling SF/F writers and the author/editor of a line of business books. ASHLEY GRAYSON is on panels 1I236, 3B193, 4F275, and 5C142.

HUGH S. GREGORY, a spaceflight historian and lecturer, has produced videos on Russian Spaceflight and Aviation, does presentations on astronomy and space science, and runs SpaceBase, a world wide space news service. HUGH S. GREGORY is on panels 2G148, 3E149, 4D409, 4I769, and 5B146.

JIM GROAT, comic book artist and teacher, created Red Shelland, Equine The Uncivilized, and Morphs. JIM GROAT is on panels 3N135, and 4G282.

KAREN HABER is a writer (The Mutant Season, The Mutant Prime, etc.), anthology editor (Universe), and art journalist. KAREN HABER is on panel 3E724, and autograph session 3G813.

IAN HAGEMANN has a BA in cross cultural communication, a BS in molecular biology, and a strong interest in multiculturalism in SF. IAN HAGEMANN is on panels 2H227, 2O088, 3H168, and 4G395.

GAY HALDEMAN, married to author Joe Haldeman for 28 years, is an authority on living with a writer and handling the business side of a writing career. GAY HALDEMAN is on panel 3C163.

JACK C. HALDEMAN, II, writer and GENIE SYSOP, has particular expertise in military SF and alternate history. JACK C. HALDEMAN, II is on panel 3H061.

JOE HALDEMAN has won every major SF award for his novels, stories, and poetry. JOE HALDEMAN is on panels 1G134, 3C879, 4E402, autograph session 2E803, and kaffeeklatsch 2H833.

ELLEN KEY HARRIS No biographical information available. ELLEN KEY HARRIS is on panel 3H061.

NORM HARTMAN, the book review columnist for Midnight Zoo magazine, writes stories that have appeared in various magazines and anthologies. NORM HARTMAN is on panels 3G697, and 3H281.

DAVID HARTWELL, editor of The Ascent of Wonder, an anthology of hard SF, and Northern Stars, an anthology of the best of Canadian SF. DAVID HARTWELL is on panels 2C170, 2E327, 3H066, 4E402, autograph session 4B816, and kaffeeklatsch 3D835.

GLENN HAUMAN is owner/publisher of Biblio-Bytes which sells and distributes books by authors including Harlan Ellison, Barry Longyear, and Spider Robinson via the Internet. Author of 101 Other Uses for a Condom, an AIDS awareness humor book. GLENN HAUMAN is on panels 2I764, 2L629, 3H061, and 4B339.

PATRICK NIELSEN HAYDEN is the senior editor of SF/F for TOR Books, and an occasional critic, author, and longtime fanzine fan. PATRICK NIELSEN HAYDEN is on panels 4C249, 4D247, 5C067, and kaffeeklatsch 3D835.

DAVID HAYMAN brings a businessman's perspective to economic issues in future history; he is also a devout filker. DAVID HAYMAN is on panels 3F209, 3C163, 3P189, and 5D523.

JUDITH HAYMAN is a Public Health Nurse and teacher and a filker (songwriter/performer) who was '93 conchair for FilkOntario. JUDITH HAYMAN is on panels 4F370, and 5D523.

PETER HECK is a former editor of Ace Books, a writer/editor for Waldenbooks, a mystery novelist, and a guitarist. PETER HECK is on panels 1G134, and 3D048.

MARTY HELGESEN is interested in Christian Fandom and how Christianity relates to SF/F; Marty is a librarian at City College of New York, and edits "Radio Free Thulcandra". MARTY HELGESEN is on panels 2H235, 3F178, 4E400, 5B392, and co hosts 2I688.

JENNIFER HERSHEY is an executive editor for Bantam Spectra Books. She has worked with such noted authors as David Brin, Arthur C. Clarke and others. She also edited the Hugo award nominated *The Art of Michael Whelan*. JENNIFER HERSHEY is on panels 2G728, and 4F333.

JOHN HERTZ is best known for teaching and popularizing English Regency ballroom dance, but he is also a knowledgeable costumer. JOHN HERTZ is on panels 4F263, and 4H330, as well as conducting 2L674.

JANET HETHERINGTON is the co creator and writer for the "Jannie Weezie" comic strip that appears in the *Ottawa Citizen*. JANET HETHERINGTON is on panels 3F269, 3I050, and 4G319.

SUE RYN HILDENBRAND BURNS is a professional herbalist. SUE RYN HILDENBRAND BURNS is on panel 2I541.

MIHO HIRAMOTO is on panels 4H749, and 5B420.

P.C. HODGELL is the author of *Good Stalk*, *Dark of the Moon*, and *Seeker's Mask*. P.C. HODGELL is on panels 4D354, autograph session 2C801, and kaffeeklatsch 2H833.

ALEXANDRA HONIGSBERG is a professional violist, conductor, and vocalist; a healer and hypnotherapist; a theologian; and a writer and editor. ALEXANDRA HONIGSBERG is on panels 2E656, 2H235, 2O632, and 4E077.

DAVID HONIGSBERG, game master, has created adventures for GURPS and CHAOSWORLD; he is also a musician and mystic. DAVID HONIGSBERG is on panel 4G319, and is gamemaster for 2D177.

GILLIAN HORVATH has written for *Quantum Leap*, *Forever Knight*, and various shows from TV *Ferengi Aaron Spelling*. GILLIAN HORVATH is on panels 3C726, 4F727, and 4H280.

CINDY HUCKLE is a writer, a fanzine editor, and chair for PRIMEDIA and other conventions. CINDY HUCKLE is on panels 2B638, 3G190, and 3P189.

ELIZABETH ANNE HULL has a doctorate in drama, but most of her published work is SF; she is also an editor and a teacher at William Rainey Harper College. ELIZABETH ANNE HULL is on panels 2I563, 5B027, and 5F424.

FRANKLIN HUMMEL is co founder and co chair of "NecronomiCon: The Cthulhu Mythos Convention;" he has also campaigned for many years for the inclusion of gay and lesbian characters in media SF productions. FRANKLIN HUMMEL is on panels 2B638, 2G459, and 3I216.

STAN HYDE is a theatre and English teacher specializing in SF; he also builds models of SF/F and horror subjects. STAN HYDE is on panels 2I723, 2N243, 3G328, 4F362, and 4I309.

SAUL JAFFE is the moderator of *SF Lovers Digest* on the Internet. SAUL JAFFEE is on panel 3F178.

KARL JOHANSON co-editor of the *Aurora* winning zine *Under the Ozone Hole*, is a member of the National Center for Science Education, and the B.C. Skeptics. He also makes a darn fine cheesecake. KARL JOHANSON is on panels 3C062, 4B072, 4G286, and 4L708.

PAULA JOHANSON her first book, *No Parent is an Island* (a collection of essays on being a parent who writes SF) is coming out this year, and she reviews SF & Canadian books for newspapers and magazines. PAULA JOHANSON is on panels 2F574, 3B193, and 5D499.

STEPHANIE ANN JOHANSON a fantasy artist, working in acrylics, soapstone carving, and wire sculpture. She also illustrated *The Hidden City: a Poem of Peru*. STEPHANIE ANN JOHANSON is on panel 3F137.

TERRY J. JONES is Professor of Astronomy at the University of Minnesota. His area of expertise is infrared astronomy and he has observed and written

about everything from asteroids to galaxies. TERRY J. JONES is on panels 3N273, and 4I769.

ASTRID JULIAN her story *Irene's Song* was a 1993 British Science Fiction Association Short Fiction Award Nominee, and she is fluent in German, French, and knows enough Russian to be polite. ASTRID JULIAN is on panels 2O088, 3G031, 4H284, and 4L708.

JORDIN KARE a physicist working on lasers and space propulsion at Lawrence Livermore, is a filker of some note, and considers himself a cybernetic necromancer. JORDIN KARE is on panels 2G148, 2L195, 2P091, and 5C142.

KEITH KATO on the research staff of Hughes Aerospace with a Ph.D. in experimental plasma physics. He is also a 3rd degree black belt in Shotokan karate. KEITH KATO is on panels 2B520, 3C062, 5F424, and conducts 3E196.

PHIL KAVENY has a Master's degree in Library Science, and writes post modern humorous short fiction. Titles include *Near East side Story* and *177 Kilograms*. PHIL KAVENY is on panels 1M015, and 3F209.

YASUO KAWAI currently researching SF & F art, and will be writing a series summary for *SF Magazine*. He is also fluent in Japanese. YASUO KAWAI is on panel 2C197.

GUY GAVRIEL KAY author of *The Fionavar Tapestry*, *Tigana*, and *A Song for Arbonne*. Compiler and editor of *The Siltmarillion*. GUY GAVRIEL KAY is on panels 3D880, 3F211, 4F275, and autograph session 2C801.

DOUG KEMP No bio. information available. DOUG KEMP is hosting events 3C762, and 5C763.

BART KEMPER a mechanical engineer and a freelance writer and photographer. He is a former paratrooper/combat engineer and newspaper journalist/editor. BART KEMPER is on panels 1I017, 2C451, 2H677, 3G272, and 4B161.

NANCY KILPATRICK author of *Near Death*, *The Darker Passions: Dracula*, *The Darker Passions: Dr. Jekyll & Mr. Hyde*, and *The Darker Passions: Frankenstein*, as well as editor of *Love Bites*, an erotic vampire anthology. NANCY KILPATRICK is on panels 2C871, 2H049, 3E053, and autograph session 4D818.

DONALD KINGSBURY author of *Man Kzin Wars VI*, *Man Kzin Wars IV*, *Moon Goddess and the Son*, *Baen Courtship Rite*, and *Timescape*. DONALD KINGSBURY is on panels 2F873, 3I671, autograph session 4E819, and kaffeeklatsch 2B830.

RICHARD KNAAK No biographical information available. RICHARD KNAAK is on panels 1G002, 1O075, and autograph session 3B808.

DEB KOSIBA has won awards for her artwork, and creates jewelry from precious and semi precious metals. She has also taught Celtic knotwork at several conventions. DEB KOSIBA is on panel 2C200.

ED KRAMER co editor of several anthologies, author of short stories, and perennial chairman of *DragonCon/Atlanta Comics Expo*, as well as 1995 *NASFiC* and 95 *World Horror Con*. ED KRAMER is on panels 2D035, 5D703 and kaffeeklatsch 3B834.

WALDEMAR KUMMING longtime German SF fan, he is also a retired Electrical Engineer. WALDEMAR KUMMING is on panels 1H051, and 4G286.

DAVID KUSHNER a physician (radiologist) with an undergraduate degree in physics and a major interest in filking. And he's single. DAVID KUSHNER is on panel 3H281.

ARTHUR KYLE is one of the co publishers of *GnuGnome Press*. ARTHUR KYLE is on panels 1H096, 4B339, and 4E776.

DAVID KYLE, the original publisher of *Gnome Press*, put out first novels by many SF legends; he is now one of the co publishers of *GnuGnome Press*. DAVID KYLE is on panels 1H096, and 4E776.

GEOFFREY A. LANDIS has won both Hugo and Nebula awards, holds a PhD in Physics and works at NASA Lewis. GEOFFREY A. LANDIS is on panels 3G031, and 4G286.

JOHN M. LANDSBERG has had short stories published in various magazines. For three years, He edited and published *Unearth* magazine. He lectures at University of California. JOHN M. LANDSBERG is on panels 2E656, 2N604, 3E098, 4E402, and 4I309.

TIMOTHY LANE after graduating with a degree in computer science from Perdue, he is a professional programmer and editor/publisher of *FOSFAX*. TIMOTHY LANE is on panels 2F696, 3C062, 3F209, 3G190, and 4B161.

GEORGE (LAN) LASKOWSKI, Jr. has won two Hugos for his publication *Lan's Lantern* and has been GOH at many conventions. GEORGE (LAN) LASKOWSKI, Jr. is on panels 3C163, 3G190, 3I216, 4I082, and kaffeeklatsch 2B830.

JUDY LAZAR is a Director with a Biotech firm in New Jersey and a skeptic. JUDY LAZAR is on panels 2H227, and 4H090.

EVELYN LEEPER is a book reviewer, convention and travelogue reporter, with interest in *Sherlockiana* and alternate history. EVELYN LEEPER is on panels 1M015, and 3C222.

MARK R. LEEPER is a film reviewer on Internet and founder of the AT&T SF Society. He has been published in *Starship Express* and other magazines. MARK R. LEEPER is on panels 2B221, and 3E098.

FREDERICK LERNER is an editor, SF columnist and author of *Modern Science Fiction* and the *American Literary Community*. FREDERICK LERNER is on panels 2C611, 3I671, 4D350, and 4F410.

DONNA LETTOW is the Script Coordinator on *Highlander:the Series*. DONNA LETTOW is on panel 3C726.

SHARIANN (S.N.) LEWITT is the author of 6 novels from *Ace Books*, and a new novel, *Memento Mori*, due from TOR in 1995. SHARIANN (S.N.) LEWITT is on panels 1I614, 2C451, 2E656, 2H227, autograph session 3D810, and kaffeeklatsch 4D839.

KUO YU LIANG has been Sales Manager for *Del Rey* books since 1993. He has never owned a cat. KUO YU LIANG is on panel 3B224.

ANDRE LIEVEN is a member of *Ottawa Science Fiction Society* and chaired *MapleCon 12*. ANDRE LIEVEN is on panels 2E327, 2G148, 3C222, and 5B146.

KATHIE LOGUE works part time as an abuse counselor and full time for *Newbury Comics* in New England. KATHIE LOGUE is on panels 1F516, 4F242, and 4I625.

BARRY B. LONGYEAR Hugo, Nebula and Campbell Award winning author of over a dozen novels. BARRY B. LONGYEAR is *ConAdian's* toastmaster, see *Program Book* for biography. BARRY B. LONGYEAR is on panels 2D552, 2E656, 4E441, 4F242, 4H890, autograph session 3H814, and kaffeeklatsch 2H833.

JEAN LORRAH author of the *Savage Empire* series, the *Sim/Gen* series and four *Star Trek* novels. JEAN LORRAH is on panels 1I614, 3D657, 3H226, 4B339, 4G889, autograph session 2B800, and kaffeeklatsch 2F832.

WILLIAM R. LUND has appeared as an actor on stage, in film and TV, and as a writer of genre articles for *Fangoria*, *Comic Scene* and others. WILLIAM R. LUND is on panels 1M619, 2I044, 4F242, and 4H280.

PERRIANNE LURIE is a Physician, an epidemiologist working in Public Health and Preventive Medicine. PERRIANNE LURIE is on panels 2G459, 2H227, 4I625, and 5E228.

BRAD LYAU has degrees in history, a PhD from University of Chicago, and has published articles on both American and European SF. BRAD LYAU is on panels 1H096, 2F561, 2H677, and 4F263.

LOIS MANGAN is a Registered Nurse working in an Acute Care Unit for a major teaching hospital in Boston. LOIS MANGAN is on panels 4C266, 4E441, and 4H090.

DANIEL MARCUS is a fiction writer and mathematician, published in Asimov's, Mag of F&SF as well as The Journal of Computational Physics. DANIEL MARCUS is on panels 2H677, 3I659, 4B241, and 4D354.

GEORGE R.R. MARTIN is a Hugo, Nebula, Balrog, Bram Stoker, World Fantasy Award winning author and five time winner of the LOCUS award. GEORGE R.R. MARTIN is on panels 3D048, 3G883, 4E077, 4H280, autograph session 2C801, and kaffeeklatsch 2F832.

JULIA MARTIN is a professional game editor with TSR. She has worked on Forgotten Realms and Advanced D&D. JULIA MARTIN is on panels 1H615, 2I541, 3D631, 4B339, and 4G319.

CAROL MATAS is one of the foremost writers of young adult fiction; her novels include Lisa, Daniel's Story, and Sworn Enemies. CAROL MATAS is on panel 4I004

CARL MATHESON is a professor of philosophy with interesting theories on the themes and intellectual realities of horror movies. DR. CARL MATHESON is presenting 2G780.

JOE MAYHEW now retired from Library of Congress, is a cartoonist, fiction writer, playwright, and does SF reviews for TV and newspaper. JOE MAYHEW is on panels 2C022, 2M250, 4D247, and 5B392.

J. D. MAYNARD recent panelist at MagiCon, Dr. Maynard is a pediatrician in private practice. J. D. MAYNARD is on panels 2D014, 2H227, and 4C266.

SALLY MCBRIDE has had short fiction published by Asimov, Mag of F&SF and others. SALLY MCBRIDE is on panels 2G024, and 5D499.

ANNE McCAFFREY award winning author of the Pern novels, among dozens of others, lives in Ireland. ANNE McCAFFREY is ConAdian's Author Guest of Honour, see program book for biography. ANNE McCAFFREY is on panels 2C739, 3D106, 3H281, 4G395, and 4I309.

SHAWNA MCCARTHY is a full time literary agent, Hugo award winner, and editor of Science Fiction Age. SHAWNA MCCARTHY is on panels 2E597, 2H144, and 3E053.

WIL MCCARTHY has his degree in Aerospace Engineering, has been published by numerous magazines, and has three published novels. WIL MCCARTHY is on panels 2D552, 4E402, 4I309, and 5B392.

MAUREEN MCHUGH has been published by Asimov's, Mag of F&SF, has two Hugo nominations, and a new novel from TOR in October. MAUREEN MCHUGH is on panels 3E053, 3I659, 4B241, 4H284, and autograph session 4C817.

ERIN MCKEE is a Fantasy and SF artist who did the cover for Piers Anthony's Alien Plot as well as many award winning paintings. ERIN MCKEE is on panel 3H238.

BRIDGET MCKENNA has been published in Pulphouse, Amazing Stories and other magazines, and writes mystery novels featuring detective Caley Burke from Berkley. BRIDGET MCKENNA is on panel 2C451, autograph session 4F820, and kaffeeklatsch 3D835.

BETH MEACHAM is an Executive Editor with TOR and has been published by TOR and DAW. BETH MEACHAM is on panels 2D621, 3G328, and 4I309.

KEN MELTSNER has a PhD in Metallurgy and works in the Aerospace Industry. KEN MELTSNER is on panels 1I017, 2H235, 3F178, and 4E400.

JUDITH MERRIL No bio. information available. JUDITH MERRIL is on kaffeeklatsch 4F840.

EDMUND R. MESKYS has published Neikas since 1962 and won a Hugo in 1967, with two additional nominations in 66 & 89. EDMUND R. MESKYS is on panels 1H615, 5D220, and kaffeeklatsch 2D831.

RIC MEYERS wrote SF articles for Starlog, worked for Atlas Comics, contributed to Twilight Zone and has a new trilogy from Dell Books. RIC MEYERS is on panel 2N243, 3G328, 4B107, and 4F362.

CRAIG MILLER worked on Star Wars and The Empire Strikes Back, writes scripts for TV shows, and chaired the 1984 WorldCon. CRAIG MILLER is on panels 2E740, 3E098, and 4H280.

DIANE MILLER has an MA in Sociology and is non fiction review editor of the SFRA Review. DIANE MILLER hosts SFRA events at con.

SASHA MILLER No biographical information available. SASHA MILLER is on panels 1I633, 3D048, 3H658, and 5D423.

BETSY MITCHELL is an Editor at Warner Books. BETSY MITCHELL is on panels 2H331, 4F275, and kaffeeklatsch 4H841.

REBECCA MOESTA see REBECCA MOESTA ANDERSON

SUSAN MOHN works with Wizards of the Coast, publishers of "Magic, the Gathering". SUSAN MOHN is on panels 2H732, and 3B733.

ELIZABETH N. MOON has written seven independent novels and two collaborations as well as two dozen published short stories. ELIZABETH N. MOON is on panels 2H049, 3G272, 4C612, 4H090, autograph session 2B800, and kaffeeklatsch 3B834.

ROGER E. MOORE edited Dragon Magazine until 1993, then moved on to TSR. He has written numerous stories, articles and game books. ROGER E. MOORE is on panels 3D631, and 4E402.

SANDRA C. MORRESE author of several short stories, one of which will appear in DAW's Sword & Sorceress II (Summer 1994), Sandra taught Creative Writing in Missouri. SANDRA C. MORRESE is on panels 2I044, 3E053, 3N273, 4G395, and autograph session 2D802.

DERRYL MURPHY is SF Columnist for The Edmonton Journal and has had his work published in Tesseracts. DERRYL MURPHY is on panels 2E327, 3C222, 4G282, and 5B406.

PETER NICHOLLS Has written four non fiction genre books and won the Hugo, Gilgamesh and Pilgrim awards among others. PETER NICHOLLS is on panels 2E449, 2I563 and autograph session 2H806.

DAVID NICKLE is a newspaper reporter who has sold five short stories and numerous non fiction articles, and is an Aurora Award winner. DAVID NICKLE is on panel 3C222.

JACK NIMERSHEIM has published over 800 articles and two dozen books as a contributor and columnist for computer magazines. JACK NIMERSHEIM is on panels 1I236, 2B520, 3I671, 4G282, and autograph session 4D818.

LARRY NIVEN Hugo and Nebula award winning author of Mote In God's Eye, Ringworld, and many others. LARRY NIVEN is on panel 2G033, and kaffeeklatsch 2B830.

GERALD NORDLEY is a writer and astronomical engineer, with dozens of published articles and stories in SF and technical magazines. GERALD NORDLEY is on panels 2D014, 2F696, 4C409, and 4G286.

JODY LYNN NYE has written fifteen books and a few dozen short stories including The Dragonlover's Guide To Pern. JODY LYNN NYE is on panels 4C612, 5B027, 5D423, autograph session 2B800, and kaffeeklatsch 2H833.

TERRY O'BRIEN is a gamer, art collector, long time fan and convention runner. TERRY O'BRIEN is on panels 1O075, 2G459, 2H235, and 3D657. VAL ONTELL is a community college librarian who has chaired conventions and is currently on the committee for Con Dor in San Diego. VAL ONTELL is on panels 2B638, 2C022, and 3P189.

MASAMICHI OSAKO well known as an expert on the worldcon in Japan. He established "Contact ET" program in their SF convention. MASAMICHI OSAKO is on panels 2C197, 3F346, and 4H749.

LISE OTTO is the representative for Canadian home brewing supply house, Brewers Direct. LISE OTTO is on panel 2I736.

JOHN M. PARK has sold short stories to Galaxy, Cities In Space, Tesseracts and Tomorrow.

SIMON PARKINSON Owner of Dragon Games, designer of Empire City of the Sun, and is active as a Game Moderator SIMON PARKINSON is on panel 2I773.

FREDERICK PATTEN works for Streamline Pictures bubbling Japanimation for theatrical and TV distribution. FREDERICK PATTEN is on panel 3B093.

TERESA PATTERSON is a Master Class Costumer, has been a Chelsea Award Nominee. Her first story appeared this summer in Dragon's Eye from Baen. TERESA PATTERSON is on panel 2E458.

ROSS PAVLAC Co Chaired the 1982 WorldCon and has spent 28 years in fandom. ROSS PAVLAC is on panel 4C266, and co hosts 2I688.

PEGGY RAE PAVLAT No biographical information available. PEGGY RAE PAVLAT hosts event 2B748.

HAYFORD PEIRCE has been writing for twenty years; his short fiction has appeared in Analog, Omni, Galaxy, and other magazines, and three novels have been published by Tor. HAYFORD PEIRCE is on panels 2B520, 2F574, and 3G328.

CHARLES PELLEGRINO is the scientist whose work was the basis for Jurassic Park. His first fantasy novel, Flying To Valhalla., is now out in paperback. CHARLES PELLEGRINO is on panels 2F047, 3N273, 4G299, and kaffeeklatsch 4B838.

SANDRA PETTINGER has won many awards as a Master costumer. SANDRA G. PETTINGER is on panels 3F137, and 5D115.

PIERRE PETTINGER is a noted costumer and current President of The International Costumers Guild. PIERRE PETTINGER is on panels 3F137, and 5D115.

FREDERIK POHL No biographical information available. FREDERIK POHL is on panels 2F874, 5B420, 5E129, and autograph session 3C809.

ANDREW PORTER has been in fandom for 35 years and in publishing for 31 years; he has won two Hugos for fanzines and semi pro zines. ANDREW PORTER is on panel 3G190, and 4G282.

JONATHAN VOS POST is an internationally known scientist, editor, author, and consultant who has worked in many areas of the space program, from Voyager to Moon Base and Mars Base. JONATHAN VOS POST is on panels 1I017, 2G148, 5C142, autograph session 2D802, and kaffeeklatsch 4B838.

BERNARD REISCHL (alias Admiral K Hack zantai Krautt, leader of the Klingon Assault Group of Kanada) is an award winning artist, costumer, model builder, editor and art director fanzines. BERNARD REISCHL is on panels 4E715, and 4H716.

MIKE RESNICK Winner of two Hugos. Recent books: Purgatory, Inferno, Purgatory, and Lucifer Jones. Author of 36 SF novels, 81 SF stories, 8 SF collections, and editor of 21 SF anthologies. MIKE RESNICK is on panels 2D035, 3E881, 3H066, autograph session 4H822, and kaffeeklatsch 4D839.

BEVERLY RICHARDSON has pursued a strong interest in vampires for several years. BEVERLY RICHARDSON is on panels 1M619, 2F718, 3O310, and 4G617.

CARRIE RICHERSON is a promising new writer whose work has appeared in several SF and horror magazines. CARRIE RICHERSON is on panels 2H049, 4B241, 4I082, 5B406, and autograph session 3D810.

JEANNE ROBINSON, although best known as a gifted writer, is a star dancer and choreographer who, before CIS was cancelled, was shortlisted for a seat on the Space Shuttle to dance in zero G. JEANNE ROBINSON is on panel 4I891, host of 1L741, autograph session 2I807, and kaffeeklatsch 3H837.

SPIDER ROBINSON is a writer who effortlessly combines painfully proficient punster and thoughtful pundit; many consider him to be the heir apparent of Robert Heinlein. SPIDER ROBINSON is on panel 4I891, host of 1L741, autograph session 2I807, and kaffeeklatsch 3H837.

MURRAY ROGOW and Roberta Rogow have credits that include filking, fanzines, humor, and collaboration. MURRAY ROGOW is on panel 3C163.

MARY ROSENBLUM has published more than 25 short stories since 1988; her first two novels have been released by Del Rey with a third due out in September. MARY H. ROSENBLUM is on panels 2E458, 2D014, 2I044, 3E053, and 4B241.

ROBERT RUNTE our fan Guest of Honour, see program book for bio. ROBERT RUNTE is on panels 2B638, 2E327, 3B093, and 4D247.

KRISTINE KATHRYN RUSCH is the editor of The Magazine of Fantasy and Science Fiction and has published six novels, most recently Heart Readers and Alien Influences. KRISTINE KATHRYN RUSCH is on panels 1G002, 2E597, 2H876, 3B193, and autograph session 3F812.

CHRIS A. RUTKOWSKI is a science educator and astronomer with an interest in UFOs and weird phenomena. CHRIS A. RUTKOWSKI is on panel 1M782, and kaffeeklatsch 4D839.

HILARY RYAN is a physician, enthusiastic member of the Star Trek Association of Regina, and eager live action gamer. HILARY RYAN is host of panel 4D320.

CHARLES C. RYAN is the editor of Aboriginal SF and First Books, and a managing editor for TOR. CHARLES C. RYAN is on panels 2E597, 3H066, and kaffeeklatsch 2H833.

GEOFF RYMAN is a British writer whose award winning work includes Unconquered Countries and The Child Garden: or A Low Comedy. GEOFF RYMAN is on panels 1I614, 2H331, 2N604, 3F882, 4C386, and autograph session 4D818.

DR. WILLIAM (ANTONY SWITHIN) SARJEANT, a professor of geology and a novelist, has merged rock science and fantasy into a happy co-existence. DR. WILLIAM SARJEANT is on panels 1G002, 2H331, and 5D325.

RON SARTI is interested in military history and wargaming; his first novel, the Chronicles of Scar, will be published in 1995. RON SARTI is on panels 1G134, 2F047, 2O088, and 4C386.

YURI SAVCHENKO founder and current president of the SF Club of Moscow State University. Issued "Informational sVodka" newsletter. YURI SAVCHENKO is on panel 3D450.

ROBERT SAWYER is the Canadian Regional Director of SFWA. Author of Golden Fleece, and winner of the 1992 Aurora Award. ROBERT SAWYER is on panels 2E327, 3C222, 4H330, and 5E129 and autograph session 2I807, and kaffeeklatsch 4D839.

ELIZABETH SCARBOROUGH is a fantasy novelist; she has written Powers That Be and Power Lines in collaboration with Anne McCaffrey. ELIZABETH ANNE SCARBOROUGH is on panels 2C739, 3D332, 3H281, 4C612, 5B027, and autograph session 4G821.

RALPH SCHIANO is a literary agent with The Hampton Agency and one of the co-publishers of GnuGnome Press. RALPH SCHIANO is on panels 4E776, and 4G282.

STANLEY SCHMIDT editor of Analog since 1978, author of The Sins of the Fathers, Lifeboat Earth and others. STANLEY SCHMIDT is on panels 2D552, 4D350, and 4F410.

HOWARD SCRIMGEOUR is a veterinarian and enthusiastic fan with many years of concom experience. HOWARD SCRIMGEOUR is on panels 2B520, 4B161, 4H090, 5D523, and 5E228.

DR. KUMAR SHARMA is a professor of physics who is known for building a nuclear mass spectrometer out of duct tape, scrap metal, and baling wire. DR. KUMAR SHARMA presents 4I781.

CHARLES SHEFFIELD is the author of Transcendence, Cold as Ice, Brother to Dragons, Dancing with Myself, One Man's Universe and others. CHARLES SHEFFIELD is on panels 2D335, 3E884, 5B146, and autograph session 2E803.

MARK SHEPHERD co-wrote Wheels of Fire, and Prison of Souls with Mercedes Lackey. MARK SHEPHERD is on panel 2G687, and autograph session 3F812.

MAGI SHEPLEY circulation director/production assistant for Post Pioneer. MAGI SHEPLEY is on panel 3G190, and hosts 2G342, and 4E626.

JOSEPHA SHERMAN writer/editor of children's fantasy and adult SF and fantasy. JOSEPHA SHERMAN is on panels 2D621, 2H144, 4I004, 3B878, 3F211, 5F267, autograph session 4F820, and kaffeeklatsch 4B838.

TAKUMI SHIBANO fluent in Japanese, publisher of Japan's oldest fanzine, and winner of the Big Heart Award and ConFrancisco's Special award. Takumi started Japan's nationalcon in 1962. TAKUMI SHIBANO is on panels 3F346, 4H749, and 5B420.

LANCE SIBLEY active in fandom since 1991, and Artistic Director of the Ontario based Standard Orbit Players, which performs musical Star Trek parodies at cons. LANCE SIBLEY and the players perform 1M348, and 2M783.

ROBERT SILVERBERG Hugo and Nebula award winning author, former Worldcon Guest of Honor, and author of lotsa books and stories. ROBERT is on panel 2H331, and autograph session 3G813.

JANNA SILVERSTEIN editor and convention liaison for Banlam Spectra, Janna also has begun writing short fiction. She's recently edited Star Wars: Truce at Bakura and Batman: Knightfall. JANNA SILVERSTEIN is on panels 2G728, 2H144, 4D408, and autograph session 3G813.

GLENN SIMSER published Taper's Guide to Recorded Filk Music, the 1991 update thereof, and 10 Years of Filk: A Discography of Performers. He's been filking in Canada for 10 years. GLENN SIMSER is on panel 5D523.

MICHAEL SKEET '92 Aurora winner for Best Short Fiction (Breaking Ball in Tesseracts3) and co winner of the '93 Aurora for editing Tesseracts 4. Nationally syndicated film critic on CBC Radio. MICHAEL SKEET is on panels 2E327, 2N243, 3E098, and 3G031.

DEAN WESLEY SMITH editor and publisher of award winning Pulphouse: A Fiction Magazine, writer of three novels and over 60 published short stories. He's also a five time Hugo nominee. DEAN WESLEY SMITH is on panels 1G002, 2E597, and 3B193.

LEAH ZELDES SMITH co editor of Hugo nominated Stet, journalist, food editor and restaurant critic. Leah has also recently sold two short stories in upcoming DAW anthologies. LEAH ZELDES SMITH is on panel 1F516.

RICHARD "DICK" SMITH co editor of Stet, which is read in 33 countries, and published Uncle Dick's newzine. Also Down Under Fan Fund administrator with wife, Leah. RICHARD "DICK" SMITH is on panel 1F516.

SUSAN SMITH has a PhD in biochemistry. She is currently an assistant professor in the Department of Nutritional Sciences at the U of Wisconsin. She conducts research on gene cloning and embryo development. SUSAN SMITH is on panels 2B520, 3G697, 3H168, and 5D220.

TIMOTHY LANE SMITH computer programmer with interest in languages: German, Latin, French, Italian, Turkish, Finnish, Japanese and Swahili. He's also created a few new ones. TIMOTHY LANE SMITH is on panels 2E639, and 2I352.

KEN SMOOKLER Toronto Lawyer and ConCom member of the 1973 Wcon. KEN SMOOKLER is on panel 1G646.

CARO SOLES holder of several language degrees, she edits erotic dark fantasy and science fiction for gay men. She also writes short stories and teaches a novel course at George Brown College. CARO SOLES is on panels 2F047, and 4D354.

KATE SOLEY has a short story published in Drabble 2, and has written a number of filk songs. She's an assistant librarian in England and makes pottery creatures. KATE SOLEY is on panels 1I633, 2D552, 2I352, and 3F211.

MARTHA SOUKUP no biographical information available. MARTHA SOUKUP is on panel 2I563, autograph session 4E819, and kaffeeklatsch 3F836.

HEATHER SPEARS her third SF book, Moonfall/Twinworld Trilogy will be launched here at ConAdian. She's the winner of several literary awards, fluent in Danish, and is an artist. HEATHER SPEARS is on panels 2B870, and 3G760.

HENRY SPENCER founding member of the Canadian Space Society, and was head of mission planning for the Canadian Solar Sail Project. HENRY SPENCER is on panels 2H235, 4C409, 5B146, and 5C359.

DALE SPROULE co editor of Communique, the newsletter of SF Canada. He has sold fiction to over 20 magazines and anthologies, and hopes to have sold his first novel by ConAdian. DALE SPROULE is on panels 1O075, and 2M622.

STANDARD ORBIT PLAYERS the Ontario based group performs musical Star Trek parodies at cons. STANDARD ORBIT PLAYERS perform 1M348, and 2M783.

KEVIN STANDLEE California BNF and Hugo rule monger. KEVIN STANDLEE is conducting 1I361, 1K641, 2D642, 3D720, 4D721, and 5D758.

ALLEN STEELE award winning author of The Jericho Iteration, Rude Astronauts, Labyrinth of Night, Lunar Descent, Orbital Decay, and Clarke County, Space. ALLEN STEELE is on panels 1I017, 1M015, 3I659, autograph session 2F804, and kaffeeklatsch 4F840.

DAVID M. STEIN a member of the Dorsai Irregulars, he says he's been in every kind of fandom. He has chaired many conventions and started two. He's been a SF/TV/movie fan forever. DAVID M. STEIN is on panel 3B093, and 4I625.

DAVID G. STEPHENSON a member of the International Academy of Astronautics Committee on International Programs and Policies, Sub committee on Lunar Development, and the Canadian Aeronautical and Space Institute. DAVID G. STEPHENSON is on panels 1L675, 4C409, 4I769, and 4L708.

ALAN STEWART is a Chemical Engineering graduate who publishes a fanzine 'Thyme'. Alan is Vice-President of the Australian SF Foundation, and currently chairing the Australian in '99 Worldcon bid. 1994 DUFF delegate to north america.

PRAS STILLMAN has sold short stories to Pulpouse and Midnight Zoo, and had two stories in Spells Unbound. Pras' day job is in Industrial Medicine, and her hobby is sculpting using salvaged objects. PRAS STILLMAN is on panels 2C451, and 2P091.

ART STINNER would like to put the 'science' back in science fiction; in his article, "The Physics of Star Trek," for New Scientist magazine he discussed matter/antimatter conversion, FTL travel, and subspace communication. ART STINNER presents 4I781.

S. M. STIRLING Canadian author of recent Snowbrother, Prince of Sparta, and The Rose Sea, and co author (with GoH Anne McCaffrey) of The Ship Who Fought. S. M. STIRLING is on panels 2I877, 3H658, 4B072, 4F370, 5E129, 5F267, autograph session 4C817, and kaffeeklatsch 2D831.

PERRY MARK STRATYCHUK he recently self published his SF and horror chapbooks. He's also a poet, an actor, an electronic artist and an award winning independent filmmaker residing in Canada. PERRY MARK STRATYCHUK is on panels 1I236, and 4F362.

JOHN STRICKLAND, JR. a programmer for the state of Texas. John is also the founder and chair of the Austin chapter of the National Space Society and Heinlein Award coordinator. JOHN STRICKLAND, JR. is on panels 2B519, 2F696, 3I775, 4B072, 4F410, and 4I769.

HARRY C. STUBBS aka Hal Clement, was first published in Astounding Science Fiction in 1942, and has been in print most of the time since. Other novels include Iceworld, Star Light and Still River. HARRY C. STUBBS is on panels 1H615, 1M015, 2E055, 2G033, 4D886, 5E129, and kaffeeklatsch 3H837.

LINDALEE STUCKEY district librarian for Berkeley Public Schools in Illinois, Lindalee has recently written a teacher's guide to SF and Fantasy, and helped to start the Golden Duck awards. LINDALEE STUCKEY is on panels 2C022, 2D621, 3F211, 4F263, and 4I004.

CHARLENE TAYLOR an authority on Australian Aboriginal art, Charlene has taught art for 23 years, including computer art on Macs. She also has a soft spot for teddy bears. CHARLENE TAYLOR is on panel 4D379.

AMY THOMSON author of Virtual Girl, Amy is now finishing Crossing the Distance. She was recently nominated for the John W. Campbell award, and reviews SF/F for the Seattle Times. AMY THOMSON is on panels 1I236, 4G395, and autograph session 2F804.

LORNA TOOLIS Head Librarian of the Judith Merril Collection Library in Toronto. LORNA TOOLIS is on panel 3D657.

JEAN LOUIS TRUDEL editor of Top Secret, the newsletter of SF Canada, and former editor of 'Communique'. He also helped organize a TV quiz game for high school students, and was a guide at the University of Toronto's observatory. JEAN LOUIS TRUDEL is on panels 1H096, 4C386, 4D385, 4F888, autograph session 2G805, and kaffeeklatsch 3B834.

HARRY TURTLEDOVE No biographical information available. HARRY TURTLEDOVE is on panel 4H330, and autograph session 3D810.

MARY A. TURZILLO has recently sold short stories to Asimov's, Tomorrow, Xanadu, F&SF, Universe and SF Age. She is an associate professor at Kent State University, and founded the Cajun Sushi Hamsters from Hell. MARY A. TURZILLO is on panels 2D057, 2M622, 3N273, 4F370, 5F267

KATHY TYERS author of the recently released Star Wars: The Truce at Bakura, she has also written Firebird, Fusion Fire, Crystal Witness, and Shivering World. Kathy is also a flutist and Irish harper. KATHY TYERS is on panel 4D408, and co hosts 2I688.

CHRISTINE VALADA an attorney interested in creator's rights, Christine is also a professional photographer who's captured faces of almost 400 SF/F authors, artists, editors and other professionals for the Worldcon Portrait Gallery. CHRISTINE VALADA is on panels 1H006, and 2F047.

HENRY VANDERBILT No biographical information available. HENRY VANDERBILT is on panel 2F561, 4C409.

TOM VEAL is a lawyer with particular insight into the business (taxes, retirement, etc.) side of a writing career. TOM VEAL is on panel 3P189

ARIANE VON ORLOW is finishing her Masters degree in English language and literature, with a particular interest in the literary ancestry of SF. She is also a member of the US based Science Fiction Research Association. ARIANE VON ORLOW is on panels 1H096, 5B420, and 5E129.

ELISABETH VONARBURG French author of the award winning novels The Silent City, and In the Mothers' Land, and her third, The Reluctant Travelers is soon to be released in English. ELISABETH VONARBURG is on panels 2H049, 3I885, autograph session 3E811, and kaffeeklatsch 2B830.

MICHAEL WALLIS has been a fan for 20 years; he's chaired 16 cons, started three fan clubs, published fanzines, and written filks. MICHAEL WALLIS is on panels 3B093, and 4I625.

MICHAEL J. WARD is a computer scientist at Adobe Systems, Inc.; his current technical project is to digitize 3000+ rare books. MICHAEL J. WARD is on panels 4E400, and 4G282.

CHRISTIAN WATERS is Assistant Director of Publicity at Bantam Books and works with authors William Gibson, Arthur C. Clarke, David Brin, and others. CHRISTIAN WATERS is on panel 2G728.

JANEEN WEBB is an Australian academic, editor, critic, and reviewer who teaches courses in fantasy and science fiction. JANEEN WEBB is on panels 3B193, 3E124, and 4G617.

LEN WEIN has worked in comic field for many years. LEN WEIN is on panel 2C581, 3H734, 5C593, autograph session 3B808, and kaffeeklatsch 2F832.

SUE WEINLEIN is an editor at TSR Games; she is the creator and organizer of "Science Fiction Saturday," a mini SF/media con held at GENCON. SUE WEINLEIN is on panels 2B638, 2E597, and 3D631.

ALLAN WEISS is a research consultant at the National Library of Canada exhibit on Canadian SF & Fantasy, and is an instructor of Canadian Studies & SF the the University of Toronto & York University. ALLAN WEISS is on panels 2E458, 3C000 and 5E126

HENRY WELCH is a professor of computer and electrical engineering; one of his many publications is "Fuzzy Logic, The Mathematical Foundations." HENRY WELCH is on panels 3B093, 3G190 and 3P189.

SCOTT WELCH is the director of public affairs for Bruce Publications and a publicist for Writers of the future. SCOTT WELCH is on panel 2P000

K. D. WENTWORTH has sold stories to several SF/

F magazines; she also teaches elementary school where she has made cafeteria riot patrol into a fine art. K. D. WENTWORTH is on panels 1I614, 3E124, 3F269, and 3H658.

MARY ELLEN WESSELS is a musician who has recorded as backup vocalist on several filk tapes; she is also a poet and has recently graduated with a degree in Children's Literature and Theater for the Young. MARY ELLEN WESSELS is on panel 5D523.

MICHAEL WHELAN is an award winning artist whose work has been featured on many book covers; his latest cover is on a collection of his own artwork. MICHAEL WHELAN is on panels 4B107, 4H759, and kaffeeklatsch 3F836.

TOM WHITMORE, who helped bring you ConFrancisco, has been attending and working cons since 1968. TOM WHITMORE is on panels 2C611, and 3B193.

RICK WILBER specializes in non fiction he has published hundreds of articles in magazines and newspapers around the country but he has also written fiction and poetry for over a dozen SF magazines and anthologies. RICK WILBER is on panel 2E458.

PERRY WILLIAMS has spent 17 years in the USAF working in military technology. PERRY WILLIAMS is on panels 3G272, and 4B161.

SHEILA WILLIAMS is the executive editor for Asimov's Science Fiction Magazine and editor or co-editor of several anthologies.

CONNIE WILLIS Co-winner of the 1993 Hugo for DOOMSDAY BOOK. CONNIE WILLIS is on panel 2G875, 3F269, 3N273, 4E441, and autograph session 4H822.

DAVID WIXON is an authority on the business of writing and on literary rights including international copyright; he is business manager for Gordon R. Dickson and literary executor for the Clifford D. Simak estate. DAVID WIXON is on panels 3B224, 4H330, 4L708, and 5C067.

GENE WOLFE worked in mechanical engineering and as senior editor on Plant Engineering Magazine before becoming a full time writer in 1984. His work includes The Book of the New Sun (4 volumes) and several short story collections. GENE WOLFE is on panels 4E402, 4G282, autograph session 2G805, and kaffeeklatsch 3H837.

DAVE WOLVERTON has published five novels, most recently The Golden Queen from Tor, several short stories, and he is editor of the annual Writers of The Future anthologies. DAVE WOLVERTON is on panels 2B007, 5B392, and autograph session 3E811.

ROBIN WULFF, who locates people and assets for a living, has a remarkable perspective on privacy issues in the computer information age. ROBIN WULFF is on panels 1F516, and 2E639.

KEN YAMAOKA is one of Japan's most active fans. Frequenter of Worldcons, and Japanese Nationalcons, Ken reports them both via slide shows. KEN YAMAOKA is on panel 3F346.

ANDREA YEOMANS performs at filk and folk concerts in the Cincinnati area and writes a filk column for The Reluctant Famulus. ANDREA YEOMANS is on panels 5D523.

JAMES YOUNG has a doctorate in history and served as an American Foreign Service Officer in both East and West Germany, Botswana, Washington, Moscow and London; he is also an author and musician. JAMES YOUNG is on panels 3H168.

ANN TONSOR ZEDDIES is an author and editor with four children; she has remarkable insight on combining a writing career with raising a family. ANN TONSOR ZEDDIES is on panels 2I044, 3E124, and 4C386.

DEALERS ROOM TABLE LOCATIONS

Zone 1

Tables	Dealers name
1-3	Pandora's Books
4	Krista P. Reid
5	Hidden Door Editions
6	Lubov Studio
7-8	TBA
9-10	Cold Tonnage Books
11-12	Almark & Co. Booksellers
13-16	William Rudow
17	Solaris
18	Dream Haven Books

Zone 2

1-6	Intergalactic Trading Co.
7	Philip Kaveny
8	Studio X
9-12	Scott & Jane Dennis
13-15	Space Debris
16	Wanda Shum
17	Valentine Armories
18	On Spec
19-21	Cotton Expressions

Zone 3

1-3	Scott Merritt
4-11	Smith Books
12-14	Offworld Designs
15-16	Birchwood Gallery
17	Glass Onion

Zone 4

1-2	Eurasis Dragon Sales
3	Ron and Gwen Kosheluk
4	South Tower Armouring
5-6	Wizard's Wagon
7	Robert Runte
8	Atomic Possum
9	Steve & Fran Scherer
10	Locus Pub.
11	Honeck Sculpture
12-13	Cat's Paw
14	Out of this World
15-16	Quantum Marketing
17	Science Fiction Chronicle
18	Assoc. of ManBook Pubs.
19	Chameleon Pubs.
20-21	McNally Robinson
22	Cryonics Society of Canada

Zone 5

1	Larry P. Ulrey
2	Mythical Creations
3	Christine K. Fulton
4	Lance Oszko
5-8	Jim Behnke - Starland
9	Angelwear Creations
10-11	Uncomyn Gifts
12-13	Sign of the Unicorn
14-15	Henderson's Books
16	Anne Paschall-Zimbell
17	Bernard Reischl

18	Comic Factory II
19	SF Canada
20-22	Environmental Awareness

Zone 6

1	Robert Pasternak
2	Champagne Dreams
3-4	Nancy Liebovitz
5-6	Flying Coyote
7	Erin McKee
8	Orca Toys
9-11	Dawn Treader Books Shop
12-14	Comic World
15-16	Patricia Wade
17	David Aronovitz
18	Off World Collectables
19-20	Michelle Demorist-Voth
21	Galaxy
22	Oddsbodkins

Zone 7

1	Isher Artifacts
2-7	C.I.B. and Assoc.
8-9	Bill Johnson
10	Lana Klassen
11	Donald Butner
12-15	Larry Smith Bookseller
16-18	Troll Video & Toys
19	NESFA
20	Flat Landers Ink
21-22	Silver Citadel

DEALERS ROOM LAYOUT

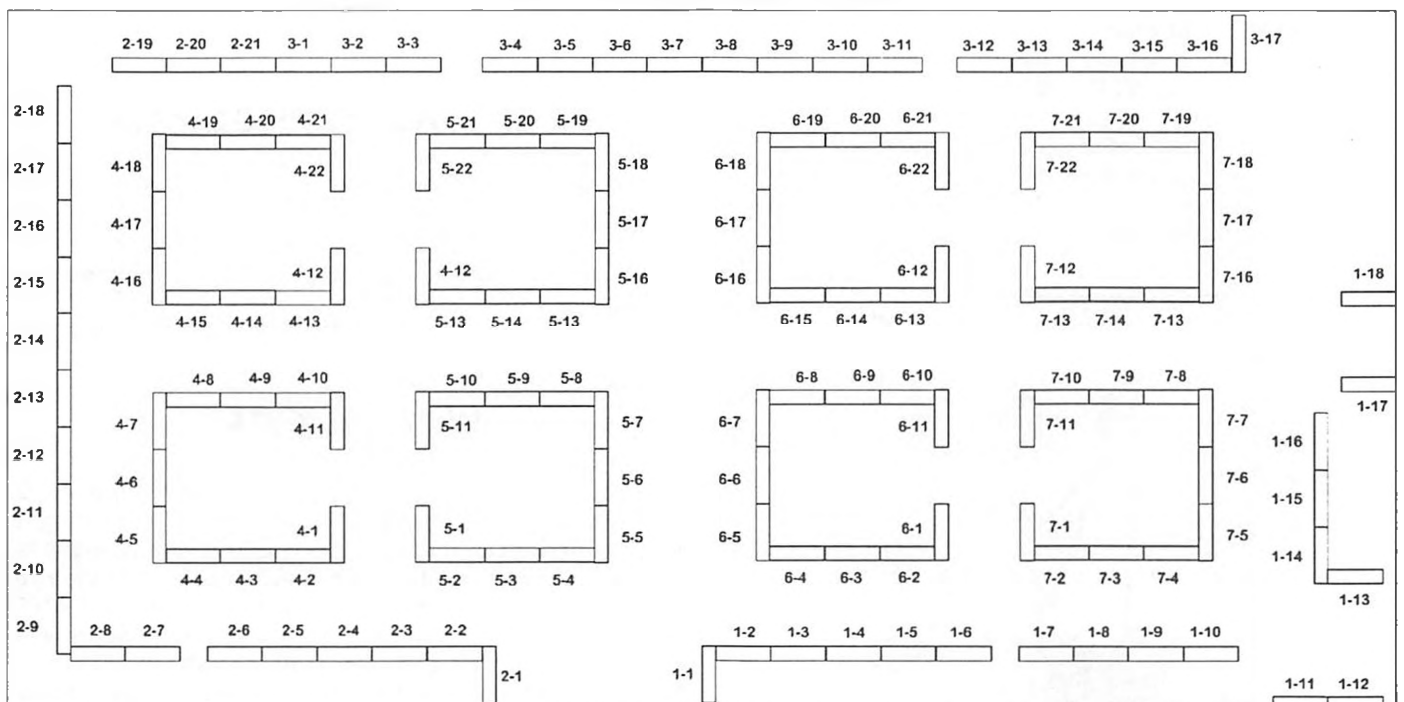

PARTICIPATING ARTISTS LIST

Auger, Marc
Bailey-Murray, Arthur/Debra
Baird, Alison
Baker, Evelyn
Ball, Georgina
Barr, George
Bartrop, Richard J.
Blanchard, N. Taylor
Broughton, Mary
Bruton, Heather
Burnett, C.H.
Carleton, Gordon
Chancellor, Ann
Condor, Cary
Ctein,
Daniels, Robert
Day, Joy
Doten, Jeff
Douglass, John
Dunning, Lee
Eggleton, Bob
Fahnestalk, Lynne Taylor
Fawcett, Lee
Fearon, Christine
Foglio, Phil/Kaja
Foster, Brad
Francis, Peter
Gdanski, Klub Fantasy
Grenier, Vala Grenier
Hail, Elizabeth
Hammel, Tim
Harvia, Teddy
Hetherington, Janet
Hickman, Steve
Holland, John
Holmes, Marc
Honeck, Butch
Huyck, Michael
Jenneman, Leslie
Johanson, Stephanie
Johnson, Kelly
Johnston, W.B.
Jones, Angela
Jones, Cathy
Kallio, Koko
Kosiba, Deb
Kuykendall, Karen
Kyle, Ruth
Lake, Lissanne
Lockwood, Todd
Longendorfer, Edwin
Longendorfer, John
Lubov
Luoma, Robert
MacKenna, Merikay
Maitz, Don
Markel, Christine
Marvig, Crystal
McKee, Erin
McNary, Lucinda
Michaels, Linda
Miklis, Franz
Nadalini, Luisa
Nagata, Kim
Normand, Jean-Pierre
Pasternack, Robert
Pelz Collection
Persello, Gary Lee
Ranson, Peggy
Rice, Roberta
Ristock, Jason
Rogers, Jennifer
Rogers, Mark
Roland, Mark
Ruppel, Robh
Santara, Sandra
Sherlock,
Simon, Barbara
Stadter, Jon
Stein, Diana Harlan
Stevens, Wendy
Straathof, Gerry
Sunshine
Sutton, Ronn
Synk, Lucy
Taylor, Charlene
Torres, Dineh
Van Camp, Susan
Walling, Rene
Weitzman, Geri
Whelan, Michael
Wojtowicz, Slawomir
Woods-Fasimpaur, E. Andi
Zimmerman, Louis



TIPS AND TRICKS

Drinking Water Yes, in Winnipeg you really can drink water straight from the taps. It is clean and healthy with no disagreeable taste. You don't have to buy bottled water unless you want to.

Legal Drinking Age In case you are planning on drinking something other than water, the legal drinking age in the Province of Manitoba (and thus the City of Winnipeg) is 18.

Foreign Currency We recommend that you change your foreign currency into Canadian dollars at a bank. Most Winnipeg stores and restaurants will accept American dollars, but they often won't offer a very good exchange rate. Most Winnipeg stores and restaurants won't accept any currency other than American or Canadian. In other words, you can't use French francs or Japanese yen.

Panhandlers There are a number of panhandlers in Winnipeg's downtown area. They are generally harmless. By law, they are allowed to ask for money. You are not required to give it to them. They are not allowed to follow you around or harass you.

Walking in the City Winnipeg is a pretty safe city, and there aren't any really dangerous areas, but there are some places where you should avoid walking alone after dark: Main Street North of City Hall, The Exchange District, particularly Albert Street and Higgins and behind the Legislative Building.

Parking Downtown In most of Winnipeg parking is not a problem. However, parking downtown during the day can be difficult and expensive. In the evenings, on Sundays and on holidays parking meters are free and unoccupied spaces are much easier to find. Parking illegally is not recommended. The average parking ticket costs \$15.00 (the maximum is \$50.00), and cars do occasionally get towed away.

FILM & VIDEO PROGRAM

Film programming will be held in meeting room 3&4 in the Convention Centre during the evening hours on Friday, Sat & Sun. Due to continuing discussions between this convention and film & TV companies around the world, we cannot confirm actual film titles & times. These WILL be posted in the Daily Newsletter.

WCC CINEMA

The Convention Cinema is NOT operated by the WCC but by an absentee operator. Negotiations for renting it were hampered by both distance and an unwillingness to give consideration to different proposals. The theatre management is under the impression that FANS would go to any SF Film that is shown and popcorn will always sell. In the end, we could not afford his price. Any convention member that wishes to see films shown in the cinema will be required to pay admission.

THE CITY GUIDE

THE NUMBERS GAME.

When visiting any new city, there are certain numbers which may occasionally become very useful. They fall into three categories; communications, currency and transportation.

While it is not possible to anticipate all of the bold adventurers' needs, the following includes a paranoid list of potentially handy numbers, and timely errata.

COMMUNICATIONS:

EMERGENCY(Police,Fire,Ambulance).....	911
Tourist Info & Reception - (24 Hours).....	945-3777
Tourism Winnipeg.....	943-1970
Police Dispatch - Non-Emergency.....	986-6222
CAA - Manitoba - Road Service.....	987-6111
- General Information	987-6117
	or 987-6161
Sexual Assault Crisis Line.....	786-8631
Poison Control Centre.....	787-2591
Suicide Prevention Clinic Crisis Line.....	786-8686
Legal Aid.....	985-8500
Hospitals: Concordia Hospital.....	667-1560
Grace General.....	837-0111
Misericordia General.....	774-6581
Health Sciences Centre	
Children's.....	787-2595
Adult's.....	787-3661
St. Boniface General.....	237-2193
	or 233-8563
Seven Oaks General.....	632-7133
Victoria General.....	269-3570

CURRENCY:

The exchange rate as of August 4, 1994, according to The Bank of Canada.

U.S.\$	- 1.32
British Pound	- 2.14
Yen	- .014
Mark	- .88

DUTY FREE OR REBATING THE GST

A brief note on the GST (Goods & Services Tax). As a non-resident of Canada, if the total GST amount paid on goods or accommodations is greater than \$7.00, you may apply for a rebate. Any goods purchased for return to your country of origin qualify for the rebate. Goods consumed or left in Canada do not qualify. Rebate forms can be obtained at any Canadian Duty Free Shop, or at Canada Customs, and may be filed, with appropriate receipts through the mail.

PARKING AND TRANSPORTATION

Parking in Winnipeg falls into three categories, meters, parking lots & parkades and illegal. Forget the last option, as large men with large trucks will take your vehicle away, and even Indiana Jones would be hard pressed to unearth it once it disappears into the quagmire of the local towing sub-culture. That leaves you with meters and lots.

Meters: A basic procedure, but pay close attention to the posted times that indicate when parking is allowed. It should be clearly marked on plates on the meters themselves. Failure to heed the appointed times will result in the large men & trucks scenario, and it just gets messy from there.

Lots and Parkades: Rates in Downtown Winnipeg average \$1.25 per hour during business hours, though most lots and parkades offer some sort of all day discount, as well as an overnight flat rate.

TAXI SERVICE

Cabs are available 24 hours a day. Persons requiring a wheelchair van simply specify such when calling the dispatcher. Appointments can also be made.

Blueline	925-8887
Luxury line	925-8888
Duffy's	775-0101
Spring	774-8294
Unicity	925-3131

CITY TRANSIT

Route and Schedule Information.....986-5700

Route Names reflect the general area of the City by major street travelled on each route. Depending on the route buses run from about 6 am to 2 am at varying intervals from 10 min.(peak hours) to 25 min.

Winnipeg transit operates on Exact Fare system operators do not carry change.

Regular Fare	(age 17 & over).....	\$1.35
Reduced Fare	Children (aged 5 -16).....	\$.75
	Seniors (65+)	\$.75

Transfers - should you need to change buses to get to your destination ask the operator for a transfer at the time you pay your fare.

Request Stop - The "Request Stop" program allows passengers to exit the bus at locations other than regular Winnipeg Transit stops in the evening after 9 pm. Let the bus driver know one stop ahead of where you want to get off.

THINGS TO DO AND SEE IN WINNIPEG

This is not a complete listing, just a brief description of some of the city's highlights.

Assiniboia Downs - 3975 Portage Avenue
- 885-3330

Live thoroughbred horse racing, televised racing and pari-mutuel betting. Races will be held September 2,3, and 4. Licensed dining room.

Assiniboine Park - 986-3130

Enter via Corydon Avenue west at Shaftsbury or the west end of Wellington Crescent. This 152 hectare/ 393 acre park is Winnipeg's oldest and largest. Its attractions include picnic sites, cricket grounds, walking/bicycling paths, formal English Gardens, the Leo Mol sculpture garden and gallery, a Tudor-style refreshment pavilion, a conservatory, a world class zoo and a gift shop. Admission to the park is free, but there is an admission charge at the zoo. Zoo admission is free on Tuesdays. Open daily.

Crystal Casino - Hotel Fort Garry,
222 Broadway Ave,7th floor
- 957-2600

European-style gaming facility with baccarat, la boule, blackjack, roulette and slot machines. Bewarned: A dress code (jacket and tie required) is enforced. Open daily.

IMAX Theatre - Portage Place,
393 Portage Avenue, 3rd flr
- 956-IMAX

The theatre features a 5 1/2 story, 72 foot wide screen with a six channel surround sound system. Open daily.

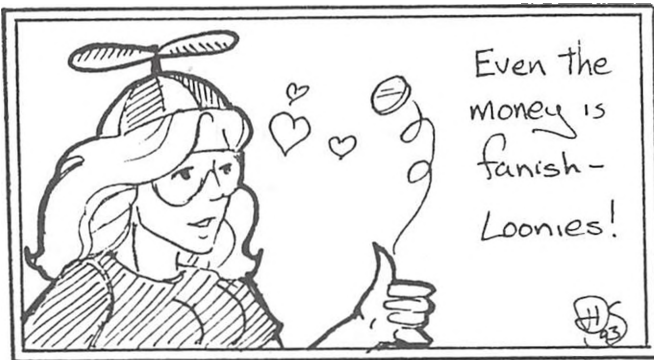

The Dark Zone - 230 Osborne Street
- 287-8710

The most advanced laser tag arena in the world. No children under the age of ten allowed. Open daily.

Exchange District

North of Portage Ave. by McDermot Ave. and Princess St. Famous for its collection of turn-of-the-century warehouse and commercial buildings. Cobble streets are dotted with shops of every kind, unique restaurants, nightclubs and art galleries.

Eaton Place - 234 Donald Street
- 989-1800

Shopping centre attached to the Eatons department store. Contains several restaurants. Many stores closed Sundays and holidays.

The Forks - Off Main Street at Water Avenue
- 943-7752 or 957-7618

A meeting place at the junction of the Red and Assiniboine rivers. There is a riverwalk leading down to the Legislative Building, the Explore Manitoba! Travel Idea Centre, the Manitoba Children's Museum (956-KIDS), the Forks National Historic Site, the Manitoba Sports Hall of Fame (985-1921), an outdoor amphitheatre, boat rentals, and boat cruises. Restaurants and shops abound in the Forks Market (942-6309), the Johnston Terminal, and the Union Station Market. Union Station is Winnipeg's only operational passenger train station.

Fort Whyte Centre - 1961 McCreary Road
- 989-8350

Environmental education centre with self-guiding outdoor trails, deer enclosure, observation tower and interpretive centre with Aquarium of the Prairies, waterfowl room, touch museum, library and gift shop. Admission fee. Open daily.

"Jesus Christ Superstar" - Concert Hall, 555 Main Street
- 780-3333

The American touring production of the popular Andrew Lloyd Webber musical takes to the stage August 30 to September 8.

Legislative Building - Broadway and Osborne Street
- 945-5813

The Legislative Building is a stately neo-classical structure built of Manitoba Tyndal stone. At its top is the famous Golden Boy statue. The grounds are home to many other statues. Free tours are offered Monday to Friday.

"Little Italy"

This section of Corydon Avenue between Pembina Highway and Stafford Avenue has a number of shops and restaurants, many of them Italian. Campaign Outfitters (452-8711), a shop specializing in science fiction and gaming, is located here.

Manitoba Museum of Man and Nature
- 190 Rupert
- 956-2830 or 943-3139

The museum, which emphasizes Manitoba's natural and human history, has been given the top ranking of three stars in the Michelin Guide of Canada. Attached are the Planetarium (943-3142) and the Touch the Universe Science Gallery. There are admission fees for the museum, the planetarium, and the Touch the Universe Science Gallery. Open daily.

McPhillips Street Station - 484 McPhillips Street
- 957-3900

A Bingo and slot machine facility that recreates the atmosphere of a turn-of-the-century railway station.

Osborne Village

Five blocks of Osborne street within walking distance of downtown are filled with shops, cafes, and restaurants.

Pendragon - 321 Portage Avenue
- 942-3427

This shop, located across from the Eatons department store downtown, specializes in gaming.

Polo Park - 1485 Portage Avenue
- 784-2501

Winnipeg's oldest and largest shopping mall. Includes the Eatons and Sears department stores, many shops and restaurants. Open daily.

Portage Place - 393 Portage Avenue
- 925-4630

Attached with enclosed skywalks to The Bay and Eatons department stores. Contains two levels of shops, services and restaurants, the IMAX Theatre, and Famous Players Theatres (movies). Some stores closed Sundays and holidays.

Prairie Dog Central
- CNR St. James Station,
- 1661 Portage Avenue
- 832-5259

This turn-of-the-century steam train, the oldest still operating in North America, travels 58 kilometres from Winnipeg to Grosse Isle and back twice every Sunday. Each trip takes about two and a half hours. Tickets cannot be purchased in advance, and trips are popular so show up early.

Shops of Winnipeg SquareConcourse,
- 360 Main Street
- 949-7140

Shops and restaurants underneath the intersection of Portage Avenue and Main Street. Closed Sundays and holidays.

St. Boniface Basilica
- 190 avenue de la Cathedrale
- 233-7304

This is the oldest basilica in Western Canada. Originally built in 1818 it has been replaced several times after fires. Louis Riel's grave is in the churchyard.

Winnipeg Art Gallery
- 300 Memorial Boulevard
- 786-6641 or 775-7297

The Winnipeg Art Gallery houses a permanent collection of contemporary, historical and decorative art, including the world's largest collection of modern Inuit art. Also housed in the building are a cinema, a restaurant, and a gift shop. Admission is free on Wednesdays. Open daily.

RELIGIOUS SERVICES

JEWISH SABBATH SERVICES

Services will be held in the Convention Centre. Times and locations as follows:

Friday, September 2 7PM - 10PM MR 6
Saturday, September 3 9AM - 12PM MR 6

WICCAN SERVICES

People will assemble by the Convention Centre Main Entrance at 9:15AM Sunday September 4th. You will be met and guided to the site. The site is within easy walking distance and handicap accessible. Washrooms will be available.

OUT ON THE TOWN

Comedy

Comedy Oasis Dinner Theatre
531 St. Mary's Rd.
231-1463

Rumor's Restaurant and Comedy Club
2025 Corydon
488-4520

Gaming

Crystal Casino
Hotel Fort Garry
957-2600

Club Regent
1425 Regent Ave.
957-2700

McPhillips Street Station
484 McPhillips St.
957-3900

British/Irish Pubs

Toad in the Hole
112 Osborne
956-2195

Latin American

Maya Lords
177 McDermot
944-8600

Alternative

Spectrum Cabaret
176 Fort
943-6487

Wellingtons - The Crypt
22 Albert
949-1390

West End Cultural Centre
586 Ellice Ave
783-6918

Country

Palomino Club
1133 Portage Ave.
772-0454

Golden Spike Roadhouse
Forks Market
942-7745

Silverado's
2100 McPhillips St.
633-9887

Rock and Contemporary

The Market Cabaret
114 Market
942-2222

Pockets Bar and Grill
171 McDermot
957-7665

Wiseguys Bar and Grill
65 Rorie St.
956-2333

The Bank
441 Main
943-2582

Palladium
2935 Pembina Hwy
275-0700

Jazz

Nibbler's Nosh
973 Corydon
284-0310

FINE DINING IN WINNIPEG

Provided for your convenience, in your registration package is the ConAdian Restaurant Guide, with a sample list of restaurants in downtown Winnipeg and some beyond. This is by no means a complete list as any trip through the restaurant listings in the MTS Yellow Pages will show you.

There are menu's available at **Information** from several of the restaurants if you want a closer look before venturing out.

BANKS

Royal Bank

Main Branch;
220 Portage Ave.

Portage & Edmonton

Osborne and Roslyn
(Circle K/Shell)

Broadway and Fort
(Hotel Fort Garry)

CIBC

560 Broadway
Broadway and Colony

336 Broadway
Broadway & Hargrave

85 Garry St.
Fort Garry Place

321 Graham Ave.
Eaton Place

Toronto Dominion

354 Portage Ave.

201 Portage Ave.
Portage and Main

473 River Ave.
Osborne and River

Bank of Montreal

Portage and Main

330 Portage Ave.
Portage and Hargrave

Portage Place
Portage and Vaughn

BOOKSTORES

Comics

Amazing Comics
Hargrave St.
942-2659

Beyond Comics
201-904 Portage Ave.
957-0142

Book Fair Comics
376 Portage Ave.
957-0142

Comic Factory 2
380 Donald
957-1978

Comic World
374 Donald
943-1968

Styx Comic Service
1858 Arlington
586-8547

Books

Mary Scorer
389 Graham Ave.
943-9600

McNally Robinson
Osborne Village
453-2644

McNally Robinson
Portage Place
943-8376

Genesis Bookstore
130 Osborne
452-0982

COMPUTER STORES

Adventure Software
337 Hargrave
942-4752

Computer Emporium
986 Portage
783-6115

Computer Valley
904 Portage
772-4575

Computerland
204 Graham
985-5300

Contact Media
938 Portage
774-7745

National Typewriter
639 Portage
944-4780

Network Innovations
102-55 Donald St.
947-1810

PHARMACIES

Medi-save Drug Mart
384 Portage Ave.
943-4446

Arbor Drugs
3-555 Balmoral St.
944-0954

Arbor Drugs
C83 Sherbrook St.
772-2616

Eatons
320 Portage Ave
957-6054

Harman's Drugstore
Portage & Sherbrook
774-7444

Hol-Rex Pharmacy
201 Edmonton St.
943-2281

Medi Park Pharmacy
640 Broadway Ave.
783-1108

Pharma Plus Drugs
Eaton Place
949-1188

Shoppers Drug Mart
(open 24 hrs)
471 River Ave
958-7000

Shoppers Drug Mart
295 Portage Ave
942-8136

Shoppers Drug Mart
Winnipeg Square
956-0944

Shoppers Drug Mart
412 Graham Ave
943-5431

LIQUOR COMMISSIONS

Hargrave & Ellice
325 Ellice Ave.
943-2887

Eaton Place
85C 234 Donald St.
942-7829

Osborne Village
469 River Ave.

Winnipeg Square
942-7119

GAS STATIONS

Petro Canada
Main & Broadway

Domo
St Mary's & Marion St

Esso
845 Portage at
Simcoe

Osborne Esso
425 Osborne St.

COSTUMERS SUPPLIES

Goofy's Bazaar
247 Notre Dame Ave
942-7041

Harlequin Costume
375 Hargrave St.
943-6300

SERVICES

Mallabar Apparrels
361 Hargrave St.
943-4506

COPY & DUPLICATION

Henry Armstrong
Winnipeg Square
958-4240

Henry Armstrong
Convention Centre
958-4243

Broadway Business
Centre
656 Broadway Ave.
774-4192

Home of Instant
Printing
75 Princess St.
942-5225

Home of the 4
Cent Copy
386 Donald St.
943-7100

Kellet Copy Centre
205 Fort St.
944-8260

Minute Man Press
205 Notre Dame St.
987-1163

The Paper Chasers
Richard Building
Lower Level
949-1163

Stationary & Office Supplies

Mad About Paper
433 River Ave.
474-2459

Grand & Toy
Winnipeg Square
943-9985

Grand & Toy
Portage Place
957-5310

Wilson Stationers
Portage Place
942-0589

GROCERY STORES

The Bay Basement
Portage & Memorial
783-2112

Bento & Sons Ltd
Forks Market
947-3484

China Town Variety 570
Main St.
949-0863

Colonnade
Convience
77 Edmonton St.
947-3709

Eatons Basement
320 Portage Ave
957-6011

Hargrave Foods & Deli
33 Hargrave St.
942-2652

Holiday Foods
156 York St.
775-2576

Holiday Foods
160 Hargrave St.
943-8387

International Grocier
176 Princess St.
943-8743

Kaufman Food Mart
NW Donald &
Broadway
947-6645

Oriental Market
& Co.
268 King St.
943-4103

Payfair
467 Sargent St.
942-6908

R&J Food Mart
206 Maryland St.
774-8095

Safeway
499 River Ave.

Safeway
Sargent & Sherbrook

Sun Food Mart
74 Donald St.
943-1193

Sun Wah
Supermarket
303 King St.
944-9162

Trung Viet Market
519 Sargent Ave
788-1012

Y-Not Foods
501 Ellice Ave.
783-0822

"CONADIAN" IS THE REGISTERED BUSINESS NAME OF CONADIAN INC., A MANITOBA NON-PROFIT CORPORATION. "WORLD SCIENCE FICTION SOCIETY", "WAFS", "WORLD SCIENCE FICTION CONVENTION", "WORLDCON", "WAFIC" AND "HUGO AWARDS" ARE SERVICES MARKS OF THE WORLD SCIENCE FICTION SOCIETY, AN UNINCORPORATED LITERARY SOCIETY. ALL RIGHTS RESERVED. ALL UNLINED ARTICLES ARE COPYRIGHTED 1994 BY THEIR AUTHORS, AND PRINTED HERE BY PERMISSION. ALL ARTWORK COPYRIGHTED 1994 BY THE ARTISTS, AND PRINTED HERE BY PERMISSION. (END)